

BRL-K744/04

Date 2019-11-01

Evaluation Guideline

for the Kiwa product certificate for Steel non-stationary storage and dispensing installations / tank containers for above ground atmospheric storage of liquids



This evaluation guideline pertains to the production of:

- steel non-stationary storage- and dispensing installations with a maximum volume of 3 m³;
 - steel non-stationary tank containers with a volume between 5 and 20 m³;
- as well as check and maintenance of steel non-stationary storage- and dispensing installations.

To be used exclusively at temporary locations.

**Trust
Quality
Progress**

Amendment to BRL K744/04

Date of amendment 8 September 2023

Technology code OGC-12: Product certification scheme's steel

Validated by Board of Experts Tank, Tank installations and Appendages dated 01 December 2023

The use of this Evaluation Guideline by third parties, for any purpose whatsoever, is only allowed after a written agreement is made with Kiwa to this end.

Validity

This amendment sheet pertains to BRL-K744/04 "Steel non-stationary storage and dispensing installations / tank containers for above ground atmospheric storage of liquids" dated 01-11-2019.

This evaluation guideline pertains to the production of:

- steel non-stationary storage- and dispensing installations with a maximum volume of 3 m³;
- steel non-stationary tank containers with a volume between 5 and 20 m³;

as well as check and maintenance of steel non-stationary storage- and dispensing installations.

To be used exclusively at temporary locations.

Re-issue of quality declarations based on this Evaluation Guideline is not necessary.

Validation

This amendment sheet has been validated by Kiwa per 01-01-2024.

Preface

This amendment sheet has been drawn up because in annex VIII "Reference drawing scope 1b" reference is made to a not existing table for the nominal plate thickness of the shell (S_r) and nominal plate thickness of the bottom, walls and top (S_t). The reference in this annex made to EN 12285-2 dished end is not equal to the requirements in paragraph 4.2.1 "General product requirements scope 1b". Both aspects are defined in the proto type approval. The minimum dimensions are given in the annex. Because the minimum sizes are also included in the relevant chapters, it was decided not to mention them in the annex and only to provide a description of the dimension symbols. After consultation with the Criteria Committee 36, it was decided to adapt the entire Annex VIII and bring it into line with paragraph 4.2.1.

Remark: In order to maintain the readability of the Evaluation Guideline, this amendment sheet contains a table with references to the changed articles and texts. See table below.

The table below indicates to which articles texts the changes apply. To maintain the readability of the Evaluation Guideline the changes are made directly in the text. Extra text and new text is highlighted. Lapsed text is strikethrough.

Date	Annex	Description	Remark
01-01-2024 (validation)	VIII	Text change	None

Preface

This Evaluation Guideline (BRL) has been accepted by the Kiwa Board of Experts Tanks, Tank installations and Appendages (TTA), in which all relevant parties in the field of steel non-stationary storage and dispensing installations / tank containers are represented. The Board of Experts also supervises the certification activities and where necessary requires the Evaluation Guideline to be revised. All references to Board of Experts in this Evaluation Guideline pertain to the above-mentioned Board of Experts.

This Evaluation Guideline will be used by Kiwa in conjunction with the Kiwa Regulations for Certification.

REMARK: THIS IS AN ENGLISH TRANSLATION OF THE DUTCH VERSION OF THIS EVALUATION GUIDELINE. IN CASE OF A DISPUTE, THE DUTCH VERSION SHALL BE BINDING.

Kiwa Nederland B.V.

Sir Winston Churchillaan 273
Postbus 70
2280 AB RIJSWIJK

Tel. 088 998 44 00
Fax 088 998 44 20
info@kiwa.nl
www.kiwa.nl

© 2019 Kiwa N.V.

Alle rechten voorbehouden. Niets uit deze uitgave mag worden verveelvoudigd, opgeslagen in een geautomatiseerd gegevensbestand, of openbaar gemaakt, in enige vorm of op enige wijze, hetzij elektronisch, mechanisch, door fotokopieën, opnamen, of enig andere manier, zonder voorafgaande schriftelijke toestemming van de uitgever.

Het gebruik van deze Beoordelingsrichtlijn door derden, voor welk doel dan ook, is uitsluitend toegestaan nadat een schriftelijke overeenkomst met Kiwa is gesloten waarin het gebruiksrecht is geregeld.

Bindend verklaring

Deze beoordelingsrichtlijn is door Kiwa bindend verklaard per 01-11-2019.

This Evaluation Guideline has been prepared by a working group (WG) with representatives from the Criteria Committee 36 (CC36) and other experts representing the market for tanks and tank storage installations. This Evaluation Guideline has subsequently been reviewed by the Criteria Committee 36. The working group and the criteria committee are constituted as follows:

Person	CC36	WG	Represents	Employer
R. Achterberg		X	Supplier tank installations	TSG
B. Broekhuizen	X	X	Manufacturer tanks and appendages / inspection company non-stationary storage tank installations	Van der Ziel Milieutechniek
P. Bus		X	Supplier pipes and appendages for tanks and tank installations	TSE / TCT
B. van Dalen *1	X	X	Certification body	Kiwa
P. Dekker	X	X	Association of Tank installation companies	Mokobouw
M. Houtzager	X		Manufacturer tanks	Altermij de Gouwe
J. Jacobi	X		Leverancier tankinstallaties / controlebedrijf niet-stationaire opslagen afleverinstallaties	Jacobi Tanks
A. Mulder	X	X	Manufacturer tanks and appendages	TAB de Blesse
J. Peters *2	X	X	Certification body	Kiwa
J. Riepe	X		Manufacturer tanks	GPI
E. Sterken	X		Manufacturer tanks	A. Leering
S. Tuinhof		X	Supplier tanks / inspection company non-stationary storage tank installations	TTS
H. Tolsma	X		Manufacturer tanks, tank installations and appendages / inspection company non-stationary storage tank installations	Tolsma Tankbouw
J. Tolsma		X	Manufacturer tanks, tank installations and appendages / inspection company non-stationary storage tank installations	Tolsma Tankbouw
E. Vervelde		X	Manufacturer tanks	Robex
M. Zwartveld		X	Service and maintenance of pumps and dispenser sumps	Fuelsys

(*1) Chairman committee and working group

(*2) Secretary committee and working group

Beside the extension with non-stationary tank containers with a volume between 5 and 20 m³, the aspects below are changed:

- Re-arrangement of chapter 4, scope 1, to present the product requirements of non-stationary storage and dispensing installations more logical.
- Requirements for bending and setting of the sheet material.
- The location of the anti-siphon device in the suction line, scope 1 and 2.
- The execution of the pressure test during a 15 yearly check (scope 2). During this test the tank must be removed from the second containment, to do an accurate leak tightness check.
- Extra aspects to check at the 2,5 yearly check (scope 2).
- Change of the frequency of third party audits.
- Earlier amendment sheets are include in the text.
- Where necessary small textual changes are included relative to the text of the BRL-K744/03.
- On request of the Board of Experts Tanks, Tank installations and Appendages, tank certificate is changed to declaration of conformity

This evaluation guideline is prepared by Kiwa.
BRL-K744/04 supersede BRL-K744/03.

Contents

Preface		1
Contents		3
1	Introduction	6
1.1	General	6
1.2	Scope	6
1.2.1	<i>Scope 1: Production</i>	7
1.2.2	<i>Scope 2: Check and maintenance</i>	7
1.3	Relation with road transport requirements	7
1.4	Acceptance of test reports provided by the supplier	7
1.5	Quality declaration	8
1.6	Declaration of conformity tank	8
1.7	Report check	8
1.8	CE marking	8
2	Terminology	9
2.1	Terms and definitions	9
2.2	Definitions	9
3	Procedure for granting a product certificate	11
3.1	Initial assessment	11
3.2	Granting the certificate	11
3.3	Investigation into the product requirements	11
3.4	Production process assessment	11
3.5	Assessment check process	11
3.6	Contract assessment	12
4	Product requirements scope 1	13
4.1	Scope 1a	13
4.1.1	General product requirements scope 1a	13
4.2	Scope 1b	14
4.2.1	General product requirements scope 1b	14
4.3	Manholes and inspection openings	15
4.4	Lifting points	16
4.5	Provisions for forklifting	16
4.6	Tank supports	16
4.7	Surge plates	16
4.8	Construction of the connections	16
4.9	Sealing of filling connection and fluid level indicator	17
4.10	Roll over safety valve	17
4.11	Interstitial space double-walled tanks	17
4.12	Filling connection and provision against spillage caused during filling	17
4.13	Construction of the second containment / container	18
4.14	Pump dispenser (scope 1a)	18

4.15	Material	18
4.16	Dimensional tolerances	19
4.17	Fabrication of the tank	19
4.17.1	Bending and setting of the sheet material	19
4.17.2	Rolling of the shell	19
4.17.3	Carbon steel contamination of high-alloy steel	19
4.17.4	Preparation of weld seams	20
4.17.5	Welding procedure specification (WPS) and welding procedure qualification (WPQ)	20
4.17.6	Welder qualifications	20
4.18	Inspection of welds	21
4.18.1	Visual inspection of welds	21
4.18.2	Radiographic testing	21
4.18.3	Magnetic particle testing	21
4.18.4	Frequency of radiographic and magnetic particle testing	22
4.19	Testing	23
4.19.1	Testing of the tank for leak tightness	23
4.19.2	Testing of the interstitial space for leak tightness	23
4.19.3	Liquid-tightness of the second containment	24
4.20	External protection against corrosion	24
4.20.1	External protection using a paint system	24
4.20.2	Corrosion protection using hot-dip galvanizing	25
4.21	Internal corrosion protection	25
4.22	Identification	25
4.23	Other provisions	26
4.24	User instructions	26
4.25	Logbook	27
5	Requirements scope 2	28
6	Marking	29
6.1	General	29
6.2	Certification mark	29
7	Quality system requirements	30
7.1	Manager of the quality system	30
7.2	Internal quality control / quality plan	30
7.3	Procedures and working instructions	30
7.4	Registration / checklist	30
7.5	Management of test and measuring equipment	31
7.6	Other requirements for the quality system	31
8	Summary of tests and inspections	32
8.1	Test matrix	32
8.2	Inspection of the quality system of the supplier	34
9	Agreements on the implementation of certification	35
9.1	General	35
9.2	Certification staff	35
9.2.1	Qualification requirements	35
9.2.2	Qualification	36
9.3	Report initial investigation	36
9.4	Decision for granting the certificate	36

9.5	Layout of quality declaration	36
9.6	Nature and frequency of third party audits	36
9.7	Non conformities	37
9.8	Report to the Board of Experts	37
9.9	Interpretation of requirements	37
9.10	Specific rules set by the Board of Experts	37
10	List of referenced documents	38
10.1	Standards / normative documents	38
Annex I	Model product certificate	41
Annex II	Model process certificate	43
Annex III	Model declaration of conformity	44
Annex IV	Model report check	45
Annex V	Reference drawing scope 1a (Cylindrical)	46
Annex VI	Reference drawing scope 1a (Non-cylindrical)	47
Annex VII	Reference drawing interstitial space	48
Annex VIII	Reference drawing scope 1b	49
Annex IX	IQC scheme (Example)	51
IV.1.	IQC scheme	51
IV.2.	Checklist	51
IV.3.	Quality system	52

1 Introduction

1.1 General

The requirements included in this Evaluation Guideline shall be used by Kiwa when processing an application and maintaining a product certificate for "Steel non-stationary storage and dispensing installations / tank containers for above ground atmospheric storage of liquids".

This Evaluation Guideline pertains to the production of:

- steel non-stationary storage and dispensing installations with a maximum volume of 3 m³;
- steel non-stationary tank containers with a volume between 5 and 20 m³;

as well as check and maintenance of steel non-stationary storage and dispensing installations.

Comment: To be used exclusively at temporary locations.

The stored liquids are liquid fuels and / or mineral oil products with a flash point higher than or equal to 55°C. Its storage part (tank or tank reservoir) can be cylindrical or non-cylindrical, single-walled or double-walled. If it is single-walled, it shall be placed in a second containment, the capacity of which is at least equal to the storage capacity of the storage tank.

This evaluation guideline replaces BRL-K744/03 dated 1 July 2013.

The quality declarations issued and based on scope 1 of BRL-K744/03 will lose their validity 6 months after validation of this Evaluation guideline.

The quality declarations issued and based on scope 2 of BRL-K744/03 will not lose their validity, because of the small changes between scope 2 (check and maintenance) of BRL-K744/03 and BRL-K744/04.

When performing the certification activities in relation to this Evaluation Guideline, Kiwa shall use the requirements stipulated in NEN-EN-ISO/IEC 17065.

1.2 Scope

The products are intended for use for non-stationary storage at temporary locations and when necessary for dispensing of fluids. The classification of liquid fuels and / or mineral oil products is in line with the PGS classes. For road transport the ADR classes are binding. See table below, for an overview of relevant PGS and ADR classes.

PGS Class	Flash point	ADR class	Examples
PGS Class 2	23°C ≤ flash point ≤ 55°C ¹	Class 2, PG III	Kerosene, spirit, solvent, jet fuel
PGS Class 3	55°C ≤ flash point ≤ 100°C	Class 3 ² , PG III	Waste oil ³ , diesel ⁴ , domestic fuel oil, gas oil, biodiesel
PGS Class 4	Flash point > 100°C	Class 3, no PG or class 9	Fuel oil, lubricating oil, brake fluid, coolant, glycol, PPO, hydraulic oils

¹) This Evaluation Guideline is applicable for the storage of liquids with a flashpoint above 55°C. In accordance with this Evaluation Guideline, an on special request non-stationary storage and dispensing installations / tank containers can be made for the storage of liquids with a flashpoint between 23 and 55°C (PGS class 2). In this case a risk inventory and evaluation (RI&E) is applicable. See BRL SIKB 7800 / BRL-K903 for methods and edit of a risk inventory and evaluation.

²) The flashpoint for using this Evaluation Guideline is limited at 55°C (PGS class 3 and 4). Labelling and packaging will be in an another way for ADR. The limit for ADR class 3 is 60°C.

³) When waste oil meets the EURAL requirements, it is considered a PGS Class 3 product.

⁴) Diesel, gasoil or light fuel oil with a flashpoint above 55°C and maximum 100°C, are labelled with UN number 1202.

Table paragraph 1.2: Risk classification according to PGS Classes and ADR for flammable liquids.

ADR-classification

Relevant ADR-Class.

-- Class 3 Flammable liquids.

Packaging groups (PG) in accordance with ADR:

Packaging group I	PG I	High danger
Packaging group II	PG II	Medium danger (flashpoint < 23°C)
Packaging group III	PG III	Low danger (23°C ≤ flashpoint ≤ 61°C)
No packaging group	No PG	Not dangerous (flashpoint > 61°C)

Non-stationary storage and dispensing installations / tank containers in accordance with this Evaluation Guideline are always suitable for road transport. For road transport non-stationary storage

and dispensing installations must fulfil to the regulations stipulated in the ADR. This Evaluation Guideline pertains in IBC's (non-stationary storage and dispensing installations), as described in chapter 6 of the ADR (code 31A) and tank containers as described in paragraphs 6.7 and 6.8 (with a volume restriction of 5 to 20 m³) of the ADR.

Comment: 31A = Rigid IBC for storage of liquids, material: steel.

Besides the production of non-stationary storage and dispensing installations / tank containers, this Evaluation Guideline also pertains in periodic checks of non-stationary and mobile storage and dispensing installations with a maximum volume of 3 m³ for above ground atmospheric storage of liquids.

This Evaluation Guideline has two scopes. Scope 1 is for production. Scope 2 is for check and maintenance. Scope 1 pertains in two types of tanks, non-stationary storage and dispensing installations and tank containers.

1.2.1 Scope 1: Production

Scope for production.

1.2.1.1 Scope 1a: Steel non-stationary storage and dispensing installations with a maximum volume of 3 m³ for above ground atmospheric storage of liquids

Product requirements and general requirements for scope 1a are described in chapter 4 / § 4.1 of this Evaluation Guideline. Quality system requirements are described in chapter 7 of this Evaluation Guideline.

1.2.1.2 Scope 1b: Steel above ground non-stationary tank containers for above ground atmospheric storage of liquids with a volume from 5 m³ to 20 m³

Product requirements and general requirements for scope 1a are described in chapter 4 / § 4.2 of this Evaluation Guideline. Quality system requirements are described in chapter 7 of this Evaluation Guideline.

1.2.2 Scope 2: Check and maintenance

Scope for check and maintenance of metal non-stationary storage and dispensing installations supplied with a registered Kiwa tank certificate or declaration of conformity tank.

Process requirements for check and maintenance are described in chapter 5 of this Evaluation Guideline. Quality system requirements are described in chapter 7 of this Evaluation Guideline.

1.3 Relation with road transport requirements

For products in accordance with scope 1 of this Evaluation Guideline, the requirements listed below are applicable for the transport of filled storage and dispensing installations / tank containers:

- Storage and dispensing installations / tank containers are suitable for ADR packaging group II and III.
- General requirements for IBC's in ADR chapter 6.5 are applicable.
- General requirements for tank containers in ADR paragraph 6.7 and 6.8 are applicable.
- Steel storage and dispensing installations are admitted with ADR code 31A.

All steel IBC's and tank containers must be inspected with a positive result by a registered authority. Besides this ADR inspection, this Evaluation Guideline is still required.

1.4 Acceptance of test reports provided by the supplier

If the supplier provides reports from test institutions or laboratories to prove that the products meet the requirements of this Evaluation Guideline, the supplier shall prove that these reports have been drawn up by an institution that complies with the applicable accreditation standards, namely:

- NEN-EN-ISO/IEC 17020 for inspection bodies;
- NEN-EN-ISO/IEC 17021-1 for certification bodies certifying systems;
- NEN-EN-ISO/IEC 17024 for certification bodies certifying persons;
- NEN-EN-ISO/IEC 17025 for laboratories;
- NEN-EN-ISO/IEC 17065 for certification bodies certifying products.

Remark: This requirement is fulfilled when a certificate of accreditation can be shown, issued either by the Board of Accreditation (RvA) or by one of the institutions with which an agreement of mutual acceptance has been concluded by the RvA.

The accreditation shall refer to the examinations as required in this Evaluation Guideline. When no certificate of accreditation can be shown, Kiwa shall verify whether the requirements of the accreditation standard are fulfilled.

1.5 Quality declaration

The quality declaration to be issued by Kiwa is described as a Kiwa product certificate or Kiwa process certificate.

A model of the product certificate to be issued based on this Evaluation Guideline has been included for information as Annex I. A model of the product certificate to be issued based on this Evaluation Guideline has been included for information as Annex II (not translated).

1.6 Declaration of conformity tank

An example of the declaration of conformity tank to be issued on the basis of this Evaluation Guideline scope 1 is included in Annex III. If necessary, Kiwa can revise this declaration of conformity tank.

1.7 Report check

An example of the report check to be issued on the basis of this Evaluation Guideline scope 2 is included in Annex IV (not translated). If necessary, Kiwa can revise this report check.

1.8 CE marking

CE marking cannot be affixed to products manufactured in accordance with this Evaluation Guideline, since there is no harmonized European standard for this product available.

Remark: Components of the non-stationary storage and dispensing installation / tank container can be affixed with CE marking such as the low-voltage directive for the electrical equipment, machine directive for the pumps and ATEX for use in potential explosive areas.

2 Terminology

2.1 Terms and definitions

In this Evaluation Guideline, the following terms and definitions apply.

Listed below the terms and definitions clarified for certification activities.

- **Authorized body for visual inspection:** Term used in PGS 30:2011, to define the body involved and responsible for the check of non-stationary storage and dispensing installations ensuring that processes continuously meet the requirements on which the certification is based.
- **Certificate holder:** The certificate holder is the supplier of the certified product, being the legal entity that enters into the certification agreement with the certification body.
- **Certification mark:** A protected trademark, which the supplier, whose products are deemed to meet the applicable requirements upon delivery, has been authorized to use by Kiwa.
- **Certification requirements:** Combination of functional, product and process requirements, with which it can be demonstrated that the product complies.
- **Company involved in the check of non-stationary storage and dispensing installations:** Company involved and responsible for the check of non-stationary storage and dispensing installations.
- **Declaration of conformity tank:** A document in which the supplier / tank manufacturer declares that the non-stationary storage and dispensing installation / tank container has been constructed in accordance with the regulations as laid down in this Evaluation Guideline. Used in BRL-K744/04.
- **Evaluation guideline (BRL):** The agreements made by the Board of Experts on the subject of certification.
- **Functional requirement:** Requirement to demonstrate that it is functionally possible by means of a calculation method specified in the evaluation guideline.
- **Initial assessment:** The initial assessment of the supplier and the investigation of the products in question in order to ascertain that all the requirements of this Evaluation Guideline are met.
Remark: The test matrix in § 8.1 summarizes the requirements that are part of the initial assessment.
- **Internal Quality Control scheme (IQC scheme):** A description of the quality inspections carried out by the supplier, as part of his quality system.
- **Manufacturer:** The manufacturer who manufactures the products. He can also be the supplier.
- **Process requirements:** Established method or procedure with which the intended quality is achieved.
- **Product:** A single or a composite product, or the output of a process or service.
- **Product certificate:** A document, in which the certification body declares that a product may on delivery be deemed to comply with the product specification recorded in the product certificate.
- **Product requirements:** Requirements made specific by means of measures or figures, focussing on (identifiable) characteristics of products and containing a limiting value to be achieved, which can be calculated or measured in an unequivocal manner.
- **Quality system:** The established organizational structure, responsibilities, procedures, processes and facilities that are required for implementing quality assurance.
- **Report check:** A document granted by a company involved in the check of non-stationary storage and dispensing installations, reporting the findings of the check.
- **Supplier:** The party responsible for ensuring that products and processes continuously meet the requirements on which the certification is based.
Remark: A supplier does not have to manufacture the product himself. He can use a manufacturer for this purpose.
- **Surveillance assessment:** The assessment that is carried out after the certificate has been granted in order to ascertain that the certified products or processes continue to meet the requirements stipulated in this Evaluation Guideline.
Remark: The test matrix summarizes the requirements that are part of the assessment.
- **Tank certificate:** A document in which the supplier / tank manufacturer declares that the non-stationary storage and dispensing installation has been constructed in accordance with the regulations as laid down in this Evaluation Guideline. Used in BRL-K744/01, BRL-K744/02 and BRL-K744/03.

2.2 Definitions

In this Evaluation Guideline, the following definitions apply:

- **ADR:** Accord Européen au transport international des marchandises Dangereuses par Route, European agreement regarding international road transport of dangerous goods.
- **Filling connection:** The (pipe) connection fitted to the tank, from which the filling point is connected.
- **Filling point:** Where the connection between tanker and tank installation is made in order to fill the tank.
- **High-alloyed steels:** For high-alloyed steels, the alloying element has a content of at least 5% or the total of the alloys is at least 10%; however, the iron content shall be more than 50%.
- **IBC:** Intermediate Bulk Container.
- **Leak detection medium:** A medium with the property of being able to give an indication of whether a leak is present.
- **Liquid fuel:** Light oil, medium oil or gas oil intended for energy conversion to power or heating/cooling.
- **Liquid tight:** The condition where a liquid has not reached the side of a tank container or second containment that is not directly in contact with the liquid.
- **Maximum capacity:** Maximum capacity of the content of the tank. The maximum capacity is always more than the nominal volume. This is not to be confused with the maximum filling or maximum filling level.
- **Maximum filling:** The maximum filling level of the tank, stated as a percentage of the nominal volume.
- **Nominal volume:** The capacity of the tank specified by the supplier and is the calculated capacity of the tank (storage). This does not include the contents of the manhole.
- **Nominal wall thickness:** Numeric designation of the wall thickness of a component, which is designed to meet the dimensions produced.
- **Relative density:** Also referred to as specific weight or specific density. Quantity that expresses how much mass of a liquid is present in a certain volume. In this Evaluation Guideline expressed in kg/l.
- **Second containment (spill container):** The provision for the storage tank(s) that retains its shape and function as a second containment for its designed life as a container for the stored liquids.
- **Soap test:** Technique in which a tank or the interstitial space is checked for leaks with a water / soap solution. The water / soap solution will foam or exhibit air bubbles in the event of a leak.
- **Stationary storage of liquids:** Tank installation which is permanently installed on site (longer than 6 months), not suitable to transport in filled condition.
- **Structural steel:** Steel that has been formed into various forms, such as beams, rods or plates, and is used for load-bearing structural elements. These steels are indicated with an "S".
- **Tank (reservoir):** Liquid storage location or component where the liquid is stored.
- **Tank container:** Container (partly) in use for storage of liquids, and equipped with attachments to lift and transport it, by the means of road transport.
Remark: IBC's in accordance with ADR chapter 6.5 are defined as tank containers.
- **Tank installation:** Assembly of tanks, pipes, appendages, fittings and appliances.
- **Temporary:** A period shorter than 6 months.
Comment: Installation for use (storage and dispensing) during a period shorter than 6 months. For a period longer than 6 months, a stationary tank installation must be installed.
- **Temporary location:** Moving activities like in road construction or agriculture and projects like building sites and events (see PGS 30 annex D).
- **Total length:** Length of the container including second containment and other permanently connected parts.
- **Viscosity:** Viscosity of a liquid is a physical material property which is a measure of its resistance to deformation at a given rate.

3 Procedure for granting a product certificate

3.1 Initial assessment

The initial assessment to be performed is based on the (product or process) requirements as contained in this Evaluation Guideline, including the test methods, and comprises the following:

- type testing to determine whether the products comply with the product and/or functional requirements;
- production process assessment;
- assessment of the activities for check on non-stationary storage and dispensing installations;
- assessment of the quality system and the IQC scheme;
- assessment on the presence and functioning of the remaining procedures.

3.2 Granting the certificate

After finishing the initial investigation, the results are presented to the Decision maker (see § 9.2) deciding on granting the certificate. This person evaluates the results and decides whether the certificate can be granted or if additional data and/or tests are necessary.

3.3 Investigation into the product requirements

The certification body will investigate the to be certified products against the certification requirements as stated in the certification requirements.

3.4 Production process assessment

When assessing the production process, it is investigated whether the manufacturer is able to continuously produce products that meet the certification requirements. The evaluation of the production process takes place during the ongoing work at the manufacturer. This evaluation includes at least:

- Assessment of the design;
- The suitability of the materials purchased;
- The manufacturing along with the relevant processes required (for example welding, coating application);
- Qualification of the employees;
- Checks during the production process (e.g. inspection of welds);
- Final inspection (e.g. testing for leak tightness of the container tank, liquid tightness of the second containment);
- Internal transport and storage;
- Effectiveness of the quality system;
- Calibration status of the measuring equipment used;
- Identification.

3.5 Assessment check process

During the assessment of the check process, the company involved in the check of non-stationary storage and dispensing installations is evaluated that the processes continue to meet the certification requirements.

The evaluation is taking place during the execution of a check by a company involved in the check of non-stationary storage and dispensing installations.

This evaluation includes at least:

- Assessment of the execution of the check (2,5 yearly and 15 yearly);
- Qualification check of personnel involved in the execution of checks at non-stationary storage and dispensing installations;
- Safety during the execution of checks at non-stationary storage and dispensing installations;
- Effectiveness of the quality system;
- Calibration status of the measuring equipment used;
- Reporting and affixing of the marks.

3.6 Contract assessment

When the supplier uses production location(s) for the products to be certified, the certification body will assess the agreement between the supplier and the producer.

This written agreement, which shall be made available to the certification body, includes at least:
That accreditation bodies, scheme managers and the certification body will be given the opportunity to observe the certification activities carried out by the certification body or on behalf of the certification body at the manufacturer (production location).

4 Product requirements scope 1

This chapter contains the product requirements and test methods for:

- Scope 1a: Steel non-stationary storage and dispensing installations with a maximum volume of 3 m³ for above ground atmospheric storage of liquids;
- Scope 1b: Steel non-stationary tank containers for atmospheric storage of liquids with a volume between 5 and 20 m³.

4.1 Scope 1a

This paragraph contains the product requirements for steel non-stationary storage and dispensing installations with a maximum volume of 3 m³ for above ground atmospheric storage of liquids.

4.1.1 General product requirements scope 1a

The next general product requirements are applicable for steel non-stationary storage and dispensing installations with a maximum volume of 3 m³ for above ground atmospheric storage of liquids.

Manufacture (drawing)

A reference drawing showing the construction and measurements of a cylindrical model is included in Annex V of this Evaluation Guideline.

A reference drawing showing the construction and measurements of a non-cylindrical model is included in Annex VI of this Evaluation Guideline.

A reference drawing showing the construction and measurements of the interstitial space is included in Annex VII of this Evaluation Guideline.

UN type approval

Steel non-stationary storage and dispensing installations in accordance with scope 1a must fulfil the requirements for UN type approval (31A).

Tank capacity

The maximum capacity of the tank is 3 m³ (3,000 litres). A tolerance of -0 / + 5% shall apply to the nominal volume stated by the supplier.

Wall thickness

The minimum nominal wall thickness of the tank, second containment, outer skin and manhole construction is 3 mm.

This is applicable for both steel as stainless steel. Besides the minimum required wall thickness the requirements for wall thickness set in ADR apply.

Provision for spillage

A steel non-stationary storage and dispensing installation, in accordance with scope 1a, shall be double-walled or placed in a second containment.

If double-walled, the interstitial space (outer skin) shall be fitted to at least a height of 95% of the nominal volume. The interstitial space shall consist of one continuous area (compartmentalization of the interstitial space is not permitted).

If provided with a second containment, then the nominal volume of the second containment shall at least be equal to the nominal volume of the tank. The nominal volume of the second containment is the free space available in the second containment, which is available to receive the fluid from the tank in the event of leakage.

Connections

All connections are above the highest liquid level in the tank.

Steel non-stationary storage and dispensing installations, in accordance with scope 1a, are generally provided with the following connections:

- **Filling connection.** The filling connection is suitable for filling with a handheld fuel nozzle. The nominal diameter of the filling connection is at least DN50. If an inner pipe is provided, the liquid level must be visual through the fluid level indicator.
Remark: To prevent static electricity during filling, the filling connection is preferably provided with an inner pipe.
- **Vent / aeration.** The nominal diameter of the vent / aeration is determined by the diameter of the filling line. In general, the vent is half the diameter of the filling line connection, with a minimum of DN25. The vent must flow out in open air. The vent / aeration opening is protected against rain falling in. The vent is preferably placed in the middle of the tank to avoid the risks of

spills, if the tank is placed on an angle. To avoid inhalation of vapours during filling, it is recommended to place the vent not too close to the filling connection.

- **Fluid level indicator.** The nominal diameter of the fluid level indicator connection is at least DN40. The internal pipe of the fluid level indicator connection shall be provided with a 3 mm pressure equalization hole, fitted as high as possible in the inner pipe near the tank wall. The monitoring line must reach 20 mm lower in the tank than the suction line. The monitoring line must be at least ¼ of the pipe diameter from the bottom of the tank or, if present, at the same height as a larger inner line of the filling line.
- **Suction connection / suction pipe.** The internal suction pipe must be demonstrably leakproof. Optionally, for emergency power applications and feeding of heating and cooling equipment, a non-stationary storage and dispensing installation can be provided with a return line.
Return connection: Return connections are preferably not provided with an inner line. If an inner line is used for return, the internal pipe shall be provided with a 3 mm pressure equalization hole, fitted as high as possible in the inner pipe near the tank wall.

Pump dispenser

Steel non-stationary storage and dispensing installations, in accordance with scope 1a, can be equipped with a pump dispenser for small dispensing. A steel non-stationary storage and dispensing installation, in accordance with scope 1a, can be a part of a fuel supply for emergency power and/or a heating system.

4.2 Scope 1b

This paragraph contains the product requirements for steel tank containers for above ground atmospheric storage of liquids with a maximum volume between 5 m³ and 20 m³.

4.2.1 General product requirements scope 1b

The next general product requirements are applicable for steel tank containers with a volume between 5 and 20 m³ for above ground atmospheric storage of liquids.

Manufacture (drawing)

A reference drawing showing the construction and measurements of a tank container for atmospheric storage of liquids is included in Annex VIII of this Evaluation Guideline.

Proto type approval

Steel tank containers in accordance with scope 1b shall have a certificate of approval for the proto type.

Tank capacity

The minimum capacity of the tank is 5 m³ (5,000 litres). The maximum capacity of the tank is 20 m³ (20,000 litres). A tolerance of -0 / +5% shall apply to the nominal volume stated by the supplier.

Wall thickness

In general the following is applicable. The minimum nominal wall thickness for tank containers with a tank diameter up to 1.8 m is 3 mm. Diameters above, and provided with external protection must have a minimum nominal wall thickness of 4 mm.

Remark: External protection is protection against mechanical damages.

The wall thickness is always in accordance with wall thickness as set in the proto type approval. Besides the minimum required wall thickness in the proto type approval, the minimum thickness of 3 mm as required in this Evaluation Guideline prevail.

Provision for spillage

A tank container, in accordance with scope 1b, shall be provided with a provision for spillage of liquids stored in the tank. Accepted provisions for spillage are:

- Double-walled, where the interstitial space (outer skin) shall be fitted to at least a height of 95% of the nominal volume.
- Placed in a second containment, with a capacity equal to the nominal volume of the tank.

Connections

Steel tank containers for atmospheric storage of liquids, are generally provided with the following connections:

- **Filling connection.** The nominal diameter of the filling line is at least DN50. The filling connection is suitable for filling the tank with a fixed connection. The filling connection is suitable for an overfill prevention device that is certified according to the requirements of BRL-K636 and can be used in transportable tanks. Alternatively an equivalent system, accepted by the

certification-body can be used. To prevent static electricity during filling, the filling line connection is preferably provided with an inner pipe.

- **Vent / aeration.** The nominal diameter of the vent / aeration is determined by the diameter of the filling line. In general, the vent is half the diameter of the filling line connection, with a minimum of DN25. The vent must flow out in open air. The vent / aeration opening is protected against rain falling in. The vent is preferably placed in the middle of the tank to avoid the risks of spills, if the tank is placed on an angle. To avoid inhalation of vapours during filling, it is recommended to place the vent not too close to the filling connection.
- **Fluid level indicator.** The nominal diameter of the fluid level indicator connection is at least DN40. The internal pipe of the fluid level indicator connection shall be provided with a 3 mm pressure equalization hole, fitted as high as possible in the inner pipe near the tank wall. The monitoring line must reach 20 mm lower in the tank than the suction line. The monitoring line must be at least ¼ of the pipe diameter from the bottom of the tank or, if present, at the same height as a larger inner line of the filling line.
- **Suction connection / suction pipe.** The internal suction pipe must be demonstrably leakproof.
- **Return connection:** Return connections are preferably not provided with an inner line. If an inner line is used for return, the internal pipe shall be provided with a 3 mm pressure equalization hole, fitted as high as possible in the inner pipe near the tank wall.

The suction and return connection must be used as fixed connection (closed system), for fuel supply for emergency power and / or a heating / cooling systems.

Remark: In the case that a pump dispenser is necessary, the use of a container tank in accordance with BRL-K21013, installed in accordance with BRL SIKB 7800 / BRL-K903 is recommended.

Dispensing

Steel non-stationary tank containers for atmospheric storage of liquids, in accordance with scope 1b, can be part of fuel supply for emergency power and / or a heating / cooling systems.

Remark: Small dispensing with a pump dispenser to motorize vehicles from non-stationary tank containers, in accordance with scope 1b, is not facilitated in this Evaluation Guideline.

4.3 Manholes and inspection openings

A manhole- or inspection opening is always provided on the top of the tank.

Tanks with a capacity of more than 1 m³ (1.000 litres) must be provided with at least one manhole opening with a minimal internal diameter of 600 mm.

On non-cylindrical tanks, the manhole opening can be rectangular. The surface area of the manhole opening for a rectangular manhole shall at least be equal to the surface area of a cylindrical manhole opening with an internal diameter of 600 mm. The smallest side of this rectangle shall not be smaller than 400 mm.

In case the tank is placed in a container, the manhole opening must be easily accessible for safe entry of the tank at the time internal inspection is necessary.

Tanks with a capacity of less or equal than 1 m³ (1.000 litres) must be provided with an inspection opening with a minimal internal diameter of 300 mm. It is also allowed to provide a tank with capacity of less or equal than 1 m³ (1.000 litres) with a manhole opening.

On non-cylindrical tanks, the inspection opening can be rectangular. The surface area of the inspection opening for a rectangular inspection opening shall at least be equal to the surface area of a cylindrical inspection opening with an internal diameter of 300 mm. The smallest side of this rectangle shall not be smaller than 250 mm.

Remark: Tanks with an inspection opening are not accessible for a manual internal inspection. This would cause a shorter lifetime, as additional measurements and repairs (in the case of corrosion) can't be done.

The nominal wall thickness of the manhole- or inspection opening neck is 3 mm.

The manhole or inspection opening neck may extend to a maximum of 20 mm inside the tank body. Where the neck extends to more than 20 mm inside the tank, it shall be provided with a hole of at least 10 mm at the highest point in order to guarantee the free movement of vapours.

The nominal wall thickness of the flange and cover of the manhole or inspection opening neck is 3 mm.

Gaskets used in manhole or inspection openings must be tested at tightness.

For non-stationary storage and dispensing installations, in accordance with scope 1a, this can be proved with the inspection report for UN type approval. A pressure test at 200 kPa (2 bar(g)) is part of this type approval.

For tank containers, in accordance with scope 1b, this can be proved with the inspection report for ADR proto type approval. The test pressure is given in ADR paragraph 6.8.2.4.

The manhole or inspection opening gasket shall be easy to open. The manhole or inspection opening cover shall be bolted on.

The sealing surfaces of flanges and covers of manhole and inspection openings shall be sufficiently flat after the manufacture of the tank. During assembly, the gasket surfaces of the flanges must fit well together when the flange bolts are normally tightened. The seal of the manhole and / or inspection opening shall be "leak tight" during the leak tightness test as indicated in § 4.19.1 of this Evaluation Guideline.

The gasket shall be free of asbestos, of one-piece and without inserts and fully resistant to the stored liquid. The resistance to the stored liquid must be demonstrated and documented by the supplier / tank manufacturer.

4.4 Lifting points

Cylindrical storage and dispensing installations, in accordance with scope 1a, shall be provided with at least 2 lifting points.

Non-cylindrical storage and dispensing installations in accordance with scope 1a, and tank containers in accordance with scope 1b, shall be provided with at least 2 lifting points.

The lifting points of non-stationary storage and dispensing installations shall be designed to enable the hoisting of a non-stationary storage and dispensing installation (completely filled with water) without causing any permanent deformations or damage to the tank body. A inspection report is required to prove the suitability of the lifting points.

The angle at hook may not be greater than 60°. The storage and dispensing installation or tank container must be visually equipped with a lifting instruction. This lifting instruction must refer to the lifting points and the angle at hook.

Lifting lugs are placed in such a way that they don't bother installation works.

For inspection and maintenance, the tank of a storage and dispensing installation in accordance with scope 1a, placed in a second containment must have a provision for lifting the empty tank out of the second containment. A lifting instruction shall be included for this purpose.

A general lifting instruction shall be included in the user instructions.

4.5 Provisions for forklifting

If a non-stationary storage and dispensing installation is provided with forklift pockets, no permanent deformations or damage to these pockets may occur during lifting.

A inspection report is required to prove the suitability of the provisions for forklifting.

4.6 Tank supports

Each storage and dispensing installation and tank container (scope 1a and 1b) shall be equipped with effective tank supports. The supports shall be able to carry the weight of a full container tank and shall be able to withstand all the static and dynamic loads that may occur.

The supplier / tank manufacturer shall be able to submit a strength calculation to the certification body for evaluation purposes.

An inspection report is required to prove the suitability of the tank supports.

The supports shall be welded to the storage and dispensing installation or tank container.

4.7 Surge plates

Surge plates mounted inside the tank shall not adversely affect the slope of the tank. Internal surge plates shall not obstruct the flow of liquid on the bottom of the tank nor the flow of vapours on the top of the tank. The entire tank must remain visible or accessible for inspection and maintenance purposes.

4.8 Construction of the connections

The connections of storage and dispensing installations, as well as tank containers (scope 1a and 1b) shall be constructed as follows:

- Connections with an external thread shall protrude at least 30 mm from the tank wall and / or manhole cover.
- Screw connections shall be permanently leak-tight.

- Pipe material in which threads are cut shall have a sufficient thickness in order to prevent deformation and / or leakage of the connections after the threads have been cut.
- Welded connections are allowed.
- The connections shall be in accordance with NEN-EN 12285-2 Method 5 or 6 of Table 8.
- The connections on cylindrical tanks shall preferably be made in the longitudinal direction of the tank and be located at the highest point. Deviation from this requirement is not allowed for the liquid level indicator and vent connections of the tank.
- The distance between two connections shall be such that there is sufficient space available to mount the pipework.
- The minimum distance between 2 welded connections is 25 mm.
- The following standards apply to the connections on the tank:
 - Sealing pipe thread in accordance with ISO 7-1;
 - Threaded steel pipes and sockets in accordance with NEN-EN 10241;
 - Seamless steel sockets in accordance with NEN-EN 10242.

4.9 Sealing of filling connection and fluid level indicator

The filling connection and fluid level indicator of storage and dispensing installations and tank containers are provided with a cap that will give an airtight seal when closed manually. The gasket shall be resistant to the stored fluid.

4.10 Roll over safety valve

The vent / aeration from a storage and dispensing installations and tank containers (scope 1a and 1b) shall be provided with a roll over safety valve. This roll over safety valve must avoid, or severely restrict the leakage in the case the tank will roll over or will come in upside down position. This roll over safety valve may not inversely affect the function of the vent / aeration.

4.11 Interstitial space double-walled tanks

The interstitial space of a storage and dispensing installation and tank container (scope 1a and 1b) shall be designed to withstand a maximum pressure of 40 kPa (0.4 bar (g)). The maximum pressure for vacuum is 0.5 bar(a).

The interstitial space (outer skin) is installed such that it covers at least 95% of the nominal volume of the tank. The interstitial space shall form one continuous space (compartmentalization of the interstitial space is not permitted).

The interstitial space is provided with at least two DN 25 connections which are provided with an internal thread in accordance with ISO 7-1. The connections shall be at the highest point, at the opposite part of the interstitial space. Ensure that the interstitial space can be checked at free passage of air between the connections.

The leak detection system is provided with a clearly visible alarm. This could be a leak detection liquid container on top of the interstitial space. This leak detection liquid container must be protected against damaging.

Remark: Starting point for a functional leak detection system is that it can work without external energy source.

To prevent corrosion due to condensation in the interstitial space, it must be put under vacuum immediately after it has been constructed.

Below the requirement of the leak detection liquid, when used:

- Compatible with tank material;
- A higher relative density than the relative density of the stored liquid;
- A freezing point below -20°C.

To avoid crystallisation, leak detection liquid based on glycol may not be used in combination with galvanized steel.

4.12 Filling connection and provision against spillage caused during filling

The filling connection of the storage and dispensing and tank container (scope 1a and 1b) is placed on top of the tank.

Tank containers could have a installed pipe system outside the tank, which can bring the filling connection below the highest liquid level inside the tank. In this case the filling line and filling connection shall be installed in accordance with BRL SIKB 7800 / BRL-K903.

The filling connection shall be equipped with a provision to prevent spillage caused during filling. In the case the filling connection is below the highest liquid level, the provision to prevent spillage shall be in accordance with the requirements of BRL-K748. If the filling connection is placed above the horizontal projection of the second containment, this is classified as an effective provision to prevent spillage caused during filling.

All double-walled tanks without second containment are provided with a provision to prevent spillage caused during filling. The provision, when placed on top of the tank must have a minimum capacity of 5 litre. This provision is fixed at the tank.

The provision to prevent spillage caused during filling shall be tested leak tight.

4.13 Construction of the second containment / container

The nominal volume of the second containment or container shall be at least equal to the nominal volume of the container tank.

Comment: The second containment can also be part of the container in which the container tank is installed (scope 1b).

The second containment of a non-stationary storage and dispensing installation (scope 1a) shall be designed such that no permanent deformation occurs when it is completely filled with water. In case the second containment is part of the container, then the container shall be designed such that no permanent deformation occurs when it is completely filled with water. A calculation showing the strength of the second containment and / or container shall be available.

The second containment shall not be provided with a drain.

The second containment shall be protected from rainwater collecting in the second containment. This provision shall not bother the accessibility of the filling connection and the fluid level indicator.

If the second containment is provided with a cover, this cover must be easy to open. The cover shall be provided with a provision to lock the open cover in such a way this will not fall unexpectedly.

The entire construction of the second containment or container shall be such that it is possible to inspect the entire tank externally and to remove it from the second containment if necessary.

4.14 Pump dispenser (scope 1a)

Only non-stationary storage tanks in accordance with scope 1a can be equipped with a pump dispenser.

If a pump is installed, this pump shall be provided with an automatic shut-off nozzle.

For vehicles with their own pump installation, the suction connection at the non-stationary storage tank must be made with a leak free couplers, which closes automatically after disconnecting.

If equipped with a pump dispenser, an anti-siphon protection device in accordance with the requirements of BRL-K916 shall be installed at the highest point in the suction line close to the tank. If the pump dispenser is installed inside the second containment, this anti-siphon protection device can be installed at the pressure side of the pump.

Comment: The hose between the pump and the nozzle is normally below the highest liquid level in the tank. Based on the risks, an anti-siphon protection device is obligatory.

A shut-off valve installed at the highest point and as close as possible to the tank wall. if the pump is below the highest liquid level.

There must be a provision to store the hose and nozzle. The provision to store the hose and nozzle must be inside the second containment or cabinet which is suitable to collect liquid dripping from the nozzle.

Hoses and installation parts must be resistant to the stored liquid.

4.15 Material

The carbon steel of the tank, second containment, manhole and / or inspection opening, the construction of the manhole and inspection opening, lifting points, the frame work, the tank support and other welded parts shall as a minimum comply with NEN-EN 10025-2 Type S235JR.

For tank containers the material as given in the proto type approval must be used. It is still required to use S235JR.

Tanks can be made of an another material, for example high-alloy steel. The requirements in the ADR still prevail in the case an another material is used. The minimum mechanical properties, shall be equal or "better" than S235JR as specified in NEN-EN 10025-2. The delivery conditions for high alloy steel is specified in NEN-EN 10088-2.

Comment: ADR material requirement.

For steel the elongation at fraction, in %, shall be not less than:

$10.000/R_m$ with an absolute minimum of 20%

where:

R_m = guaranteed minimum tensile strength of the steel to be used (in N/mm²)

Remark: There is an difference between IBC's with or without additional protection made in the ADR. An additional protection may be provided by overall external structural protection, such as suitable "sandwich" construction with the outer sheathing (jacket) secured to the shell, double-walled construction or by enclosing the shell in a complete framework with longitudinal and transverse structural members. Storage and dispensing installations and tank containers in accordance with the Evaluation Guideline are classified as IBC's with additional protection. When in accordance with the ADR, a minimum wall thickness of 3 mm as required in this Evaluation Guideline still prevail.

If carbon steel is used, then the inspection documents supplied shall at least be in accordance with NEN-EN 10204:2004 article 3.2 (test report "Type 2.2").

If high-alloy steel is used, then the inspection documents supplied shall at least be in accordance with NEN-EN 10204:2004 article 4.1 (inspection certificate "Type 3.1").

The material used must be resistant to the stored liquid.

Material of the connections

The material of the connections, and any internal pipes provided, shall be resistant to the stored liquid. Except for the cap and counter flange (ring) of the fluid level indicator and filling line, the material of the connections must not be able to form a galvanic element with the material of the tank. The inner pipes, insofar as they are firmly welded, to the tank shall be made of steel. The steel shall at least be in accordance with S235JR. The inner pipes must not cause galvanic corrosion within the tank. If the tank is made of another material, for example stainless steel, then the inner pipes must also be made of this material.

Internal lines for suction, except the connection in the tank or manhole can be made in plastic.

4.16 Dimensional tolerances

Wall thickness

The minimum wall thickness of the tank, second containment, the construction of the manhole, manhole, lifting points, the frame work, and the tank support after fabrication shall not be lower than - 10% of the nominal wall thickness.

Roundness of the shell (cylindrical types)

The tolerance of the shell is $\pm 5\%$ of the indicated diameter of the tank. The allowed tolerance directly after fabrication of the inner tank shall be less than 1,5%. If in doubt the roundness of the tank must be determined by 2 perpendicular measurements at the suspected deviated roundness.

4.17 Fabrication of the tank

During the fabrication of the container tank, the following requirements pertaining to the processes used, qualification of personnel and the associated inspection shall apply.

4.17.1 Bending and setting of the sheet material

Bending and setting of the sheet material shall be as far as possible perpendicular to the rolled direction.

Remark: NEN-EN 10025-2 provides instructions on the bending of sheet material.

4.17.2 Rolling of the shell

The allowed tolerance for the diameter of the inner tank (D) shall be less than 1,5%. If in doubt the roundness of the tank must be determined by 2 perpendicular measurements at the suspected deviated roundness.

4.17.3 Carbon steel contamination of high-alloy steel

Carbon steel contamination during production must be removed from the high-alloy steel used at non-stationary storage and dispensing installations or tank containers.

If the surface of the sheet material has not been damaged or contaminated with carbon steel particles, then it is sufficient to pickle the weld seams only. After pickling and completely removing the oxide layer / impurities, the high-alloyed steel must be passivated.

If the machines and tools used for production are also used for the manufacture of carbon steel products, then the high-alloyed steel at non-stationary storage and dispensing installations and tank containers shall on completion be both pickled and passivated both internally and externally. The procedure for pickling and passivating must be documented in a procedure.

4.17.4 Preparation of weld seams

The weld seam preparation shall be in accordance with the welding procedure specification.

4.17.5 Welding procedure specification (WPS) and welding procedure qualification (WPQ)

The manufacturer of the non-stationary storage and dispensing installation and tank container shall demonstrably have approved welding procedures for all welds that are used for the production of the non-stationary storage and dispensing installations and tank containers.

Welding procedure specification

The welding procedure specification must comply with:

- NEN-EN-ISO 15609-1 "Specification and qualification of welding procedures for metallic materials - Welding procedure specification - Part 1: Arc welding";
- NEN-EN-ISO 15609-2 "Specification and qualification of welding procedures for metallic materials - Welding procedure specification - Part 2: Gas welding";
- NEN-EN-ISO 15609-3 "Specification and qualification of welding procedures for metallic materials - Welding procedures specification - Part 3: Electron beam welding";
- NEN-EN-ISO 15609-4 "Specification and qualification of welding procedures for metallic materials - Welding procedure specification - Part 4: Laser beam welding".

Remark: Welding procedure specifications prior to 2004 do not meet the above requirements. NEN-EN-ISO 15609 has replaced NEN-EN 288. It is possible that NEN-EN 288 welding procedure specifications are rewritten in accordance with NEN-EN-ISO 15609, but this is only possible if all the relevant parameters of the original WPS are well documented. The tank manufacturer shall have to demonstrate this. In all other cases the welding procedure specification shall have to be rewritten and tested again.

The manufacturer of the non-stationary storage and dispensing installation tank container must maintain a documented system in which the welding procedure specification can be traced to the welding procedure qualification.

Welding procedure qualification

The welding procedures must be qualified according to the following standards:

- NEN-EN-ISO 15607 "Specification and qualification of welding procedures for metallic materials - General rules";
- NEN-EN-ISO 15614-1 "Specification and qualification of welding procedures for metallic materials - Welding procedure test - Part 1: Arc and gas welding of steels and arc welding of nickel and nickel alloys".

The welding procedure qualification shall be assessed by an independent body, selected by the manufacturer of the non-stationary storage and dispensing installation tank container and accepted by the certification body.

4.17.6 Welder qualifications

The qualifications of welders and operators of welding machines shall meet:

- NEN-EN-ISO 9606-1 "Qualification testing of welders - Fusion welding - Part 1: Steels";
- NEN-EN-ISO 14732 "Welding personnel - Qualification testing of welding operators and weld setters for mechanized and automatic welding of metallic materials".

The initial qualification of a welder or operator of welding machines shall be issued by an independent body, selected by the manufacturer of the non-stationary storage and dispensing installation and / or tank container and accepted by the certification body.

An extension of the welding qualification shall be issued by an independent body, selected by the manufacturer of the non-stationary storage and dispensing installation and / or tank container and accepted by the certification body.

Every 6 months the manufacturer of the non-stationary storage and dispensing installation and / or tank container will document that the welder or operator of a welding machine is still working within the scope of the welding qualification.

The manufacturer of the non-stationary storage and dispensing installation and / or tank container shall have a documented system in which welders' qualifications are managed and maintained. The issue, the extension and the confirmation of the welder qualifications shall be documented.

4.18 Inspection of welds

After completion, the welds of the tank and second containment, supports and lifting points shall be visually assessed.

The welds of the tank shall be assessed by means of a radiographic or magnetic particle testing in accordance with the applicable frequency. See § 4.18.4 of this Evaluation Guideline for the applicable frequency.

Remark: Radiographic testing applies to cylindrical tanks. Magnetic particle testing (or dye penetrant testing) applies to non-cylindrical tanks.

4.18.1 Visual inspection of welds

The welds of each non-stationary storage and dispensing installation and / or tank container shall be visually inspected.

The welds of the tank, second containment, supports and lifting points shall at least meet the requirements of NEN-EN-ISO 5817 quality level D.

If during a visual inspection it is determined that a weld may not meet the required standard, it must be assessed and remeasured in accordance with NEN-EN-ISO 6520-1 and NEN-EN-ISO 5817 and repaired if necessary. The repair shall be visually re-inspected.

4.18.2 Radiographic testing

The welds of cylindrical tanks shall be subjected to sampling inspection using the radiographic testing method.

The following standards apply to radiographic testing:

- NEN-EN-ISO 17636-1 "Non-destructive testing of welds - Radiographic testing - Part 1: X- and gamma-ray techniques with film";
- NEN-EN-ISO 10675-1 "Non-destructive testing of welds - Acceptance levels for radiographic testing - Part 1: Steel, nickel, titanium and their alloys".

The radiographic testing shall be performed in accordance with NEN-EN-ISO 17636-1 Class B. A radiographic test on a cylindrical tank in accordance with this Evaluation Guideline consists of two X-rays. A film on which the longitudinal seam is photographed at the location of an intersection and a film on which the circumference seam is photographed at the location of an intersection.

The examined welds shall at least comply with NEN-EN-ISO 10675 Class 3 (corresponds to NEN-EN-ISO 5817 Level D).

The radiographic testing shall be carried out by a person who is demonstrably qualified for this work, for example RT level 1 or RT level 2 or equivalent. The assessment of a radiographic testing shall be performed by a person who is demonstrably qualified for this work, for example RT level 3 or IWE or equivalent. The assessment is not carried out by a person who was directly involved in the welding. The radiographic testing may also be carried out by an external inspection agency that has been selected by the manufacturer of the non-stationary storage and dispensing installation and / or tank container and accepted by the certification body.

A report of the radiographic examination that is traceable to the non-stationary storage and dispensing installation and / or tank container under investigation shall be made available.

4.18.3 Magnetic particle testing

The welds of non-cylindrical tanks shall be subjected to sampling inspection using the magnetic particle method.

The following standards apply to magnetic particle testing:

- NEN-EN-ISO 17638 "Non-destructive testing of welds - Magnetic particle testing";
- NEN-EN-ISO 23278 "Non-destructive testing of welds - Magnetic particle testing - Acceptance levels".

The magnetic particle testing shall be carried out in accordance with NEN-EN-ISO 17638. A magnetic particle test of a tank shall comprise 10% of the corner welds.

The welds inspected shall at least comply with NEN-EN-ISO 23278 Class 3X (corresponds to NEN-EN-ISO 5817 Level D).

Magnetic particle testing shall be carried out by a person who is demonstrably qualified for this work, for example MT level 1 or equivalent. The assessment of a magnetic examination must be carried out by a person who is demonstrably qualified for this work, for example MT level 2, IWE or equivalent. The assessment shall not be carried out by a person who was directly involved in the welding. The magnetic particle testing may also be carried out by an external inspection agency, that has been selected by the manufacturer of the non-stationary storage and dispensing installation and / or tank container and accepted by the certification body.

A report of the magnetic particle examination that is traceable to the non-stationary storage and dispensing installation and / or tank container under investigation shall be made available.

4.18.4 Frequency of radiographic and magnetic particle testing

The inspection frequency below is for radiographic and magnetic particle testing.

Inspection frequency for non-stationary storage and dispensing installations:
Start at level 10 after finishing the initial evaluation.

Level	Minimum test amount
1	1 test per 27 tanks
2	1 test per 24 tanks
3	1 test per 21 tanks
4	1 test per 18 tanks
5	1 test per 15 tanks
6	1 test per 13 tanks
7	1 test per 11 tanks
8	1 test per 10 tanks
9	1 test per 9 tanks
10	1 test per 8 tanks
11	1 test per tank (initial evaluation)

During the initial phase, new manufacturers must test all non-stationary storage and dispensing installations.

In response to result of tests, the level can be changed in accordance with the table below:

0 negative tests	1 level down
1 or 2 negative tests	remain the current level
3 or 4 negative tests	1 level higher
5 or more negative tests	100 % testing (1 test per tank)

The evaluation period ends after testing 8 tanks.

The manufacturer of non-stationary storage and dispensing installations shall take corrective actions to avoid further welding imperfections if a high amount of negative test is found. In this case all non-stationary storage and dispensing installations shall be tested. After finding the cause of the bad welding quality, this is proved by 0 negative tests after 8 test executed, the frequency is set at level 10.

Inspection frequency for tank containers:

10% of the complete production of tank containers shall be subjected to testing. This means that radiographic or magnetic particle testing shall be carried out on at least 1 out of 10 tank containers produced in accordance with this Evaluation Guideline.

For negative tests: All imperfections found shall be repaired. The repaired area shall be re-inspected. If defects are found during radiographic testing, run to the edge of the film, the adjacent areas must also be photographed. If errors are also found in these areas, 100% of the relevant weld must be photographed. The examination of the repaired areas is not included in the determination of the testing frequency.

4.19 Testing

Tanks and the interstitial space, if present, shall be pneumatically pressure tested for leak tightness. Second containments shall be tested for liquid tightness. These tests shall be performed before the application of the corrosion protection system.

4.19.1 Testing of the tank for leak tightness

Each tank shall be tested for leak tightness with air at a pressure of 30 kPa (0.3 bar(g)).

Remark: The tank shall not be tested against vacuum.

The test pressure is measured by means of a (digital) manometer, the accuracy of which is traceable to a calibration standard.

Comment: Measurement data stored in a digital manometer can be used as supporting evidence by the certification body.

General testing sequence of the tank or compartment with air:

- Pressurize the tank.
- When the correct test pressure has been reached, the air supply (valve) on the tank shall be shut off and the compressed air supply shall be disconnected.
- Wait until the pressure has stabilized (due to temperature and setting of plates).
- After stabilization, the connections, the manhole seals and all weld seams shall be checked for leak tightness using a soap solution.
- The pressure on the tank shall be maintained for at least 15 minutes. o inexplicable pressure drop may occur.
- Leaks shall be repaired, and the test repeated in accordance with the above method.

Remark 1: No permanent deformation of the tank shall occur as a result of this test.

Remark 2: The tank including the manhole cover to be supplied shall be "airtight".

The tank is determined to be leak tight when there is no inexplicable loss of pressure during the test and when no leaks are visible when the tank is being tested with the soap solution.

The leak tightness test is not performed by the person who was directly involved in the production of the tank.

A registration or report of the leak tightness test, which can be traced back to the tested container tank, shall be available.

4.19.2 Testing of the interstitial space for leak tightness

Each interstitial space shall be tested for leak tightness.

The test pressure for the interstitial space of a double-walled tank is 40 kPa (0.4 bar(g)).

Remark: It is inadvisable to set the test pressure higher than 40 kPa (0.4 bar(g)) due to the risk of implosion of the inner tank.

The test pressure is checked by means of a (digital) manometer, the accuracy of which is traceable to a calibration standard.

General testing sequence of the interstitial space with air:

- When the inner tank is ready, it is brought to an overpressure of 30 kPa and checked for leaks by means of a soap solution.
Remark: Alternatively, the welds of the tank that will no longer be visible when the double-wall has been installed can be tested by means of a dye penetrant examination.
- A record of this test, that is traceable to the tested tank, shall be made.
- After the entire tank (inside and outside tank) has been finished, the inside tank is brought to an overpressure of 30 kPa and the visible welds of these are tested using a soap solution.
- After pressurizing the inner tank, wait until the pressure has stabilized (due to temperature and settling of plates).
- After stabilization, the connections, the manhole seals and all visible weld seams shall be checked for leak tightness using a soap solution. No indications of leakage shall be observed.
- The pressure of the tank shall be maintained for at least 15 minutes. No inexplicable pressure drop may occur.
- With the pressure still on the inner tank, the interstitial space is pressurized to an overpressure of 40 kPa.
- After stabilization, the connections and all welds of the interstitial space shall be tested using a soap solution. No indications of leakage shall be observed.

- The pressure on the interstitial space shall be maintained for at least 15 minutes. No inexplicable pressure drop may occur.
- If no leaks are found, the pressure is first removed from the interstitial space.
- Finally, the inner tank is then made pressure less.
- Leaks shall be repaired, and the test repeated in accordance with the above method.

Remark: No permanent deformation of the tank shall occur as a result of this test.

The interstitial space is determined to be leak tight when there is no inexplicable loss of pressure (or less than the indicated pressure loss is observed) during the test and when no leaks are visible when the tank is being tested with the soap solution.

The leak tightness test is not performed by the person who was directly involved in the production of the tank.

A registration or report of the leak tightness test, which can be traced back to the tested interstitial space, shall be available.

4.19.3 Liquid-tightness of the second containment

Each second containment shall be tested for liquid-tightness. All welded joints that are below the maximum liquid level shall be tested for leaks prior to the application of the corrosion protection system. This can be tested by filling the second containment entirely with water or by another comparable method (e.g. dye penetrant testing, vacuum box, etc.). The chosen method must be able to establish that the water did **not** reach the unloaded side of the second containment.

If a method other than water filling is used, this method shall be documented by the manufacturer of the non-stationary storage and dispensing installation and / or tank container in a procedure that has been accepted by the certification body.

Leaks shall be repaired and then the second containment shall be tested again in accordance with the above method.

The second containment is found to be leak-tight if no fluid leakage is visible on the unloaded side.

The leak tightness test is not performed by the person who was directly involved in the production of the second containment.

A registration or report of the leak tightness test, which can be traced back to the tested second containment, shall be available.

4.20 External protection against corrosion

The outside carbon steel of a non-stationary storage and dispensing installation or tank container shall be provided with a corrosion protection system.

Non-stationary storage and dispensing installations or tank containers constructed from high-alloy steel do not require a corrosion protection system.

4.20.1 External protection using a paint system

The outside of a non-stationary storage and dispensing installation or tank container shall be provided with a corrosion protection system suitable for the expected conditions. A non-stationary storage and dispensing installation or tank container is to be used in an outside climate. A non-stationary storage and dispensing installation / tank container shall be provided with a paint system which will give protection against corrosion in an environment with a high relative humidity and moderate pollution.

- The non-stationary storage and dispensing installation or tank container shall be provided with a durable paint system with a life expectancy of at least 5 years in an environment with a high relative humidity and moderate pollution.
Remark: These conditions are equal to atmospheric corrosion category C3 as indicated in NEN-EN-ISO 12944-2.
- The paint system must be documented in the IQC scheme. This shall include a declaration with the life expectancy and warranty of the paint system, set up by the supplier of the paint.
- The adhesion of the paint system shall be tested by a cross cut test in accordance with NEN-EN-ISO 2409. A procedure for this test must be documented. The test frequency must be set in the IQC scheme. Minimum required is class 2 in accordance with NEN-EN-ISO 2409.
- The design of the tank may not influence the application of the paint system. All surfaces to paint must have easy access and sharp edges must be avoided.

- A remark shall be made in the case a higher atmospheric corrosion category is required by the buyer / user of the non-stationary storage and dispensing installation or tank container. This remark shall give information about the inappropriateness of the standard paint system. A paint system with a higher atmospheric corrosion category must be offered.
- It is not allowed to use different paint systems through each other.

Most important aspects for the application of the paint system:

- Manage the required conditions during the painting (temperature, relative humidity, dew point, etc.).
- Information regarding the highest and lowest dry film thickness and the minimum and maximum overcoating time.
- The measurements required along with the required measuring equipment.
- Preparation of the surface (cleaning, blasting, degreasing, etc.).
- Procedure for application of an appropriate paint system at welding seams. After welding the surface in the heat affected zone must be prepared for the application of paint. This could be blasting (Sa 2,5 in accordance with NEN-EN-ISO 8501-1), brushing or passivating.
- A procedure for aftercare (in the case repairs are necessary at a damaged tank). This procedure must give information of the initial paint system used, and recommendations for the repairment (including preparation of the surface and precautions).

The Evaluation Guidelines below can be used:

- BRL-K758 "Coating suitability of metal products to be coated";
- BRL-K21012 "Exterior paint systems for steel above ground storage tanks";
- BRL-K790 "The application of coating systems to steel pipes or steel storage tanks for liquids".

Conformity with the requirements for external protection using a paint system in this Evaluation Guideline is proved, in the case the paint system of a non-stationary storage and dispensing installation or tank container is applied in accordance with the BRL-K790.

4.20.2 Corrosion protection using hot-dip galvanizing

A non-stationary storage and dispensing installation or tank container can be hot dip galvanized. A comparable level of protection is obtained as with the application of a paint system, as indicated in § 4.20.1 of this Evaluation Guideline.

Remark: It is also possible to galvanize parts of a non-stationary storage and dispensing installation or tank container.

Hot dip galvanizing shall be carried out in accordance with NEN-EN-ISO 1461.

The following aspects regarding hot-dip galvanizing require consideration:

- Control of the molten zinc bath (other metals).
- Data regarding the highest and lowest limits in relation to the thickness of the steel used. See tables 3 and 4 of NEN-EN-ISO 1461.
- The measurements required along with the required measuring equipment.

4.21 Internal corrosion protection

As an option, the inside of a carbon steel non-stationary storage and dispensing installation or tank container can be provided with an corrosion protection system.

The inside of the tank can be provided with an internal coating. In that case use can be made of the following Evaluation Guidelines:

- BRL-K758 "Coating suitability of metal products to be coated";
- BRL-K779 "Internal coating of steel tanks for flammable liquids";
- BRL-K790 "Application of coating systems to steel pipes or steel storage tanks for liquids".

Remark: Based on experience, internal corrosion protection in tanks of non-stationary storage and dispensing installations is rarely used, as damage could easily occur during transport. Only cylindrical tanks are eligible for an effective internal coating to be applied. In the case of non-cylindrical tanks, the wall deformation will have to be taken into account and can result in possible cracking.

4.22 Identification

The following information shall be provided on each non-stationary storage and dispensing installation or tank container:

- Name of the supplier or his trademark;
- Tank number;

- Year of manufacture (will not apply if the tank number of UN-mark provides this information);
- Nominal volume in m³;
- The word mark "KIWA";
- UN-mark;
- Date of inspection.

The above mentioned information is indelibly marked on a corrosion-resistant identification plate. The identification plate shall be made of a durable material (for example brass, bronze, aluminium or stainless steel). The identification plate must be affixed by means of rivets, or by other similar durable means, on an underlying steel strip that is welded to the non-stationary storage and dispensing installation or tank container. The identification plate shall be placed on a clearly visible location on the outside of the non-stationary storage and dispensing installation or tank container.

An identification number must also be stamped into the manhole flange (tank side), manhole neck or at another recognizable place (for example lifting point or welded-on strip). This stamped identification must be traceable to the tank number.

Remark: During fabrication this identification could be a production number.

4.23 Other provisions

The following provisions shall be provided on each non-stationary storage and dispensing installation or tank container:

- A lifting instruction including the angle at hook, placed on two opposite sides of the non-stationary storage and dispensing installation / tank container;
- A document holder for the logbook.

For storage of diesel, the labels listed below shall be applied to each non-stationary storage and dispensing installation or tank container (this is under responsibility of the user):

- ADR Pictogram Class 3 Flammable liquids;
- ADR Pictogram "Environmental Hazard" (leafless tree / dead fish);
- Pictogram "No fire; open flame and smoking prohibited" in accordance with XVIII by art. 8.10 of Dutch Working Conditions Regulation, or in letters with a minimum height of 5 cm "No fire; open flame and smoking prohibited".

All other requirements in relation with ADR must be fulfilled by the user.

4.24 User instructions

The supplier of the non-stationary storage and dispensing installation or tank container must supply user instructions and draw the users' attention to those aspects that may endanger humans, animals and / or the environment. Also, aspects that may have a negative effect on the life expectancy, as well as all other aspects that the supplier deems worth mentioning shall be included in these instructions.

Relevant aspects in laws and regulations are leading for the user instructions.

At least the following aspects shall be included in the user instructions of the tank:

- Proposed use of the non-stationary storage and dispensing installation or tank container and the liquid to be stored in it.
- The maximum filling level (maximum 95%) and filling instruction.
- Requirements for transport and the applicable regulations for transport.
- Information on the external corrosion protection provided on carbon steel tanks (atmospheric corrosion category, environmental conditions, expected life expectancy, etc.).
- Information on the internal corrosion protection information, if applicable.
- Guidance for the user pertaining to the parts covering the leak detection system as supplied by supplier / tank manufacturer.
- Warning regarding the maximum pressures allowable in the tank and the interstitial space. The interstitial space is not designed for high pressures. Pressures above 40 kPa (0.4 bar (g)) can lead to the implosion of the inner container tank.
- Lifting instructions and an instruction for removing the tank from its second containment or container.
- Requirements regarding storage and dispensing at a temporary location in relation to regulations.
- Restricted use of the tank container. The use of a tank container is only allowed with a fixed connection.
- Information regarding the mandatory inspections and checks.
- The supplier / tank manufacturer issued a declaration of conformity. This declaration of conformity contains all data, except the UN-mark and inspection date, in § 4.22 from this Evaluation Guideline.

- Important information is to be recorded prior to the delivery of the non-stationary storage and dispensing installation or tank container in order to prevent misunderstandings (such as capacity, single-walled construction in combination with a second containment or double-walled construction, pipe connections, gasket material, etc.).
- Operating instructions for the delivery system, if supplied.

4.25 Logbook

Each non-stationary storage and dispensing installation or tank container shall be supplied with a logbook. This logbook contains:

- The declaration of conformity tank;
- Brief user information;
- Registration lists for inspections;
- Inspection reports.

5 Requirements scope 2

This chapter contains the requirements for periodically check and maintenance of metal non-stationary and mobile storage and dispensing installations with a maximum volume of 3 m³ for above ground atmospheric storage of liquids in accordance with scope 1a of this Evaluation Guideline.

THIS IS CHAPTER IS NOT TRANSLATED, AS THESE REQUIREMENTS ARE ONLY APPLICABLE TO DUTCH REGULATIONS.

6 Marking

6.1 General

See § 4.20 of this Evaluation Guideline for detailed information on the identification markings to be applied on new non-stationary storage and dispensing installations or tank container.

6.2 Certification mark

After entering into a certification agreement with Kiwa, the product shall be indelibly marked with the word mark "KIWA".

7 Quality system requirements

This chapter contains the requirements which shall be fulfilled by the supplier's quality system.

7.1 Manager of the quality system

Within the manufacturer's organisational structure an employee shall be responsible for managing the manufacturer's quality system.

7.2 Internal quality control / quality plan

As part of the quality system the manufacturer must implement an internal quality control scheme (IQC scheme).

In this IQC scheme the following shall be demonstrably recorded:

- which aspects are inspected by the manufacturer;
- according to which methods these inspections are carried out;
- how often these inspections are carried out;
- how the inspection results are registered and stored.

The IQC scheme shall have an index, the version date and number and be validated by the quality system manager. This IQC scheme shall be in the format as shown in the Annex IX. The schedule must be detailed in such a way that it provides the certification body with sufficient confidence that requirements will be continuously fulfilled.

Certified companies in accordance with scope 2 may use a documented quality assurance system instead of an IQC scheme provided it is supplemented with a checklist. The documented quality assurance system must include the procedures required by this Evaluation Guideline.

At the time of the initial audit, the IQC scheme or quality assurance system shall have functioned for at least 1 month.

7.3 Procedures and working instructions

The supplier shall be able to submit the following:

- procedures for:
 - dealing with products with deviations;
 - corrective actions to be taken if non-conformities are found;
 - dealing with complaints concerning products and / or services delivered;
- the working instructions and inspection forms used.

Products or services with deviations

The certified company shall have a procedure covering products or services with deviations in order to prevent any deviations in the (production) process from influencing the quality of the final product.

Remark: A product can also be a service.

Corrective actions

The certified company shall have a procedure for taking the necessary corrective actions in the case of non-conformities. The cause of the non-conformity shall be investigated, and feedback given to the relevant department.

Complaints procedure

The certified company shall have a procedure covering the handling of complaints concerning the product delivered. This procedure shall include at least the following points:

- A written procedure for handling complaints.
- A person responsible shall be assigned within the company for handling complaints.
- Complaints shall be registered.
- Feedback shall be given to the relevant department as a result of complaints.

The corrective measures resulting from the complaints shall be recorded.

7.4 Registration / checklist

During production, the processes used and the inspections and tests carried out shall be recorded on a checklist.

7.5 Management of test and measuring equipment

The certified company shall determine which test and measuring equipment are required in order to demonstrate that the product meets the requirements of this Evaluation Guideline.

When necessary, and where indicated in this Evaluation Guideline, test and measuring equipment shall be calibrated at specified intervals.

The certified company shall assess the validity of the previous tests and measurements made if the calibration reveals that the testing or measurement equipment is not functioning properly.

The test and measuring equipment shall be provided with an identification with which the calibration status can be determined.

The certified company shall record the results of all calibrations.

The certified company shall have the necessary test and measuring equipment. These resources shall also be made available to the site assessor of the certification body. This includes amongst others the equipment for leak testing, wall thickness measurements, lighting with the required light intensity for tank inspections, coating thickness meter etc.

7.6 Other requirements for the quality system

The supplier shall be able to submit the following:

- the organisation's organogram;
- qualification requirements of the personnel concerned.

Quality system

If an organization has a quality system based on NEN-EN-ISO 9001, then where possible, reference can be made to procedures or instructions that form part of this quality system.

Changes

The certification body shall be informed in the event of changes that may have consequences for the quality of the products (including design changes or changes in production) and processes. The certification body then determines whether additional evaluation is required.

Work instruction and procedures

In addition, the following documentation or model reports may be added to the IQC scheme and / or documented quality system:

- A documented system for the welding procedures;
- A documented system for the management and maintenance of welder qualifications;
- A model report for the visual inspection of the welding work;
- A model (report) which confirms that the leak tightness test has been carried out;

A production card that shows the present stage of production.

Documents / drawings

Non-stationary storage and dispensing installations and tank container shall be produced on the basis of an approved type or design that is detailed in documents / drawings. Only types approved by the certification body will be mentioned on the product certificate.

Tank compliance certificates

The certified company shall, upon delivery of the non-stationary storage and dispensing installations and tank container, prepare a declaration of conformity tank and make this available to the purchaser. The certification body will provide instructions for the preparation of the declaration of conformity tank.

8 Summary of tests and inspections

This chapter contains a summary of the tests and inspections to be carried out in the event of certification:

- **Initial investigation:** tests in order to ascertain that all the requirements recorded in the Evaluation Guideline are met;
- **Surveillance assessment:** tests carried out after the certificate has been granted in order to ascertain whether the certified products continue to meet the requirements recorded in the Evaluation Guideline;
- **inspection of the quality system of the supplier:** monitoring compliance of the IQC scheme and procedures.

8.1 Test matrix

Description of requirement	BRL §	Class	Investigation carried out for		
			Initial investigation	Inspection by certification body after certification	
				Inspection test	Frequency
Product requirements					
Scope 1a / General product requirements scope 1a	4.1/4.1.1	3	Yes	Yes, by changes	1/100 tanks
Scope 1b / General product requirements scope 1b	4.2/4.2.1	3	Yes	Yes, by changes	1/10 tanks
Manholes and inspection openings	4.3	2	Yes	Yes	1/100, 1/10 tanks
Lifting points	4.4	2	Yes	Yes	1/100, 1/10 tanks
Provisions for forklifting	4.5	2	Yes	Yes	1/100, 1/10 tanks
Tank supports	4.6	2	Yes	Yes	1/100, 1/10 tanks
Surge plates	4.7	2	Yes	Yes	1/100, 1/10 tanks
Construction of connections	4.8	2	Yes	Yes	1/100, 1/10 tanks
Sealing of filling connections and fluid level indicator	4.9	2	Yes	Yes	1/100, 1/10 tanks
Roll over safety valve	4.10	2	Yes	Yes	1/100, 1/10 tanks
Interstitial space double-walled tanks	4.11	2	Yes	Yes	1/100, 1/10 tanks
Filling connection and provisions against spillage caused during filling	4.12	2	Yes	Yes	1/100, 1/10 tanks
Construction of the second containment / container	4.13	2	Yes	Yes	1/100, 1/10 tanks
Pump dispenser (scope 1a)	4.14	2	Yes	Yes	1/100, 1/10 tanks
Material	4.15	2	Yes	Yes	1 x per year
Dimensional tolerances	4.16		Yes	Yes	1 x per year
Fabrication of the tank; Bending and setting of the sheet material	4.17.1	2	Yes	Yes	1 x per year
Fabrication of the tank; Rolling of the shell	4.17.2	2	Yes	Yes	1 x per year
Fabrication of the tank; Carbon steel contamination of high-alloy steel	4.17.3	2	Yes	Yes	1 x per year
Fabrication of the tank; Preparation of weld seams	4.17.4	2	Yes	Yes	1 x per year
Fabrication of the tank; Welding procedure specification (WPS) and welding procedure qualification	4.17.5	2	Yes	Yes	1 x per year
Fabrication of the tank; Welder qualifications	4.17.6	2	Yes	Yes	1 x per year
Inspection of welds; Visual inspection of welds	4.18.1	2	Yes	Yes	Each visit
Inspection of welds; Radiographic testing	4.18.2	2	Yes	Yes	1 x per year / each visit

Description of requirement	BRL §	Class	Investigation carried out for		
			Initial investigation	Inspection by certification body after certification	
				Inspection test	Frequency
Inspection of welds; Magnetic particle testing	4.18.3	2	Yes	Yes	1 x per year / each visit
Inspection of welds; Frequency of radiographic and magnetic particle testing	4.18.4	2	Yes	Yes	1 x per year / each visit
Testing; Testing of the tank for leak tightness	4.19.1	1	Yes	Yes	Each visit
Testing; Testing of the interstitial space for leak tightness	4.19.2	1	Yes	Yes	Each visit, if applicable
Testing; Liquid-tightness of the second containment	4.19.3	2	Yes	Yes	Each visit, if applicable
External protection against corrosion; External protection using a paint system	4.20.1	2	Yes	Yes	Each visit
External protection against corrosion; Corrosion protection using hot-dip galvanizing <i>Corrosion protection using hot-dip galvanizing</i>	4.20.2	2	Yes	Yes	Each visit, if applicable
Internal corrosion protection	4.21	3	Yes	Yes	Each visit, if applicable
Identification	4.22	1	Yes	Yes	1/100, 1/10 tanks
Other provisions	4.23	2	Yes	Yes	1/100, 1/10 tanks
User instructions	4.24	2	Yes	Yes	1/100, 1/10 tanks
Logbook	4.25	3	Yes	Yes	1/100, 1/10 tanks
Quality system requirements					
Manager of the quality system	7.1	2	Yes	Yes	1 x per year
Internal quality control / quality plan	7.2	2	Yes	Yes	1 x per year
Procedures and working instructions	7.3	2	Yes	Yes	1 x per year
Registration / checklist	7.4	2	Yes	Yes	1 x per year
Management of test and measuring equipment	7.5	2	Yes	Yes	1 x per year
Other requirements for the quality system	7.6	2	Yes	Yes	1 x per year

THE TEST MATRIX IS WITHOUT THE REFERENCE TO REQUIREMENTS FOR SCOPE 2, AS THIS PART IS ONLY APPLICABLE TO DUTCH REGULATIONS.

Explanation of classes: Non-conformities may be found during the inspection visits. These non-conformities are classified according to the following classes:

- 1 = Critical: These non-conformities can result in dangerous or unsafe situations. The supplier shall, in consultation with the certification body, take the required corrective actions within two weeks. Exceeding this period shall result in a suspension of the certificate.
- 2 = Important: These non-conformities affect the quality of the product in the longer term. The supplier shall, in consultation with the certification body, take the required corrective actions within three months. Exceeding this period shall result in a suspension of the certificate.
- 3 = Less important: These non-conformities are less important but shall be corrected in the long term. This is checked by the certification body during the next inspection visit.

During the initial investigation of the product (scope 1), type tests shall be performed to determine if the product complies with the prescribed requirements. The requirements that shall be met are stated in the test matrix above. In the event of changes to the material used or the supplier, the type tests shall be repeated.

Also, the quality system of the supplier / manufacturer shall be assessed during the initial inspection.

After certification, the certification body shall carry out periodic inspection visits to ensure that the supplier / manufacturer continuously meets the requirements of this Evaluation Guideline. Some type tests will have to be repeated during these inspection visits.

8.2 Inspection of the quality system of the supplier

The quality system of the supplier will be checked by the certification body on the basis of the IQC scheme. The inspection consists of at least those aspects mentioned in the Kiwa Regulations for Certification.

9 Agreements on the implementation of certification

9.1 General

Beside the requirements included in this Evaluation Guideline, the general rules for certification as included in the regulations for product certification of the certification body shall also apply.

These rules are in particular:

- the general rules for conducting the pre-certification tests, in particular:
 - the way suppliers are to be informed about how an application is being handled;
 - how the test is conducted;
 - the decision to be taken as a result of the pre-certification tests.
- the general rules for conducting inspections and the aspects to be audited,
- the measures taken by the certification body in case of non-conformities,
- the measures taken by the certification body in case of improper use of Certificates, Certification Marks, Pictograms and Logos,
- terms for termination of the certificate,
- the possibility to lodge an appeal against decisions of measures taken by the certification body.

9.2 Certification staff

The staff involved in the certification may be sub-divided into:

- Certification assessor (**CAS**): in charge of carrying out the pre-certification tests and assessing the inspectors' reports;
- Site assessor (**SAS**): in charge of carrying out external inspections at the supplier's works;
- Decision maker (**DM**): in charge of taking decisions in connection with the pre-certification tests carried out, continuing the certification in connection with the inspections carried out and taking decisions on the need to take corrective actions.

9.2.1 Qualification requirements

The qualification requirements consist of:

- qualification requirements for personnel of a certification body which satisfies the requirements EN ISO/IEC 17065, performing certification activities
- qualification requirements for personnel of a certification body performing certification activities set by the Board of Experts for the subject matter of this Evaluation Guideline

Education and experience of the concerning certification personnel shall be recorded.

For scope 1

	Certification assessor / (Application) Reviewer	Site assessor	Decision maker
Basic competence			
Knowledge of business processes and ability for professional evaluation	<ul style="list-style-type: none"> • Bachelor degree or similar work and reasoning level • 1 year of relevant working experience 	<ul style="list-style-type: none"> • Vocational education at intermediate level or similar work and reasoning level • 1 year of relevant working experience 	<ul style="list-style-type: none"> • Bachelor degree or similar work and reasoning level • 5 years of working experience with a minimum of 1-year experience with certification
Audit skills	<ul style="list-style-type: none"> • Training in audit skills • Minimum of 4 complete audits of which at least 1 has been carried out independently and witnessed for qualification 	<ul style="list-style-type: none"> • Training in audit skills • Minimum of 4 complete audits of which at least 1 has been carried out independently and witnessed for qualification 	Not applicable
Technical competence			

	Certification assessor / (Application) Reviewer	Site assessor	Decision maker
Knowledge of this BRL	<ul style="list-style-type: none"> Detailed knowledge of this BRL and a minimum of 4 complete audits for this BRL or for related BRL's 	<ul style="list-style-type: none"> Detailed knowledge of this BRL and a minimum of 4 complete audits for this BRL or for related BRL's 	Not applicable
Relevant knowledge of: <ul style="list-style-type: none"> The technology related to the manufacturing of the products to be inspected, the performance of these processes and the provision of these services The manner in which the products are used, the processes are performed and the services are provided Any defect which may occur during the use of the product, any error in the execution of processes and any inadequacies in the provision of services 	<ul style="list-style-type: none"> Relevant technical education at Bachelor degree or similar work and reasoning level Detailed knowledge of cluster related BRL's Visual welding inspector VT-w Level 2 or equal 	<ul style="list-style-type: none"> Relevant technical vocational education at intermediate level or similar work and reasoning level Detailed knowledge of cluster related BRL's Visual welding inspector VT-w Level 1 or equal 	Basic knowledge of test and inspection techniques.

9.2.2 Qualification

The qualification of the Certification staff shall be demonstrated by means of assessing the education and experience to the above-mentioned requirements. In case staff is to be qualified on the basis of other criteria, this shall be recorded.

The authority to qualify staff rests with the:

- Decision makers (**DM**): qualification of certification assessors (**CAS**) and site assessors (**SAS**);
- Management of the certification body: qualification of decision makers (**DM**).

9.3 Report initial investigation

The certification body records the results of the initial investigation in a report.

This report shall comply with the following requirements:

- complete: the report provides a verdict pertaining to all requirements included in this Evaluation Guideline;
- traceability: the findings on which the verdicts have been based shall be recorded and traceable;
- basis for decision: the **DM** shall be able to base his decision on the findings included in the report.

9.4 Decision for granting the certificate

The decision for granting the certificate shall be made by a qualified decision maker (DM) who has not been involved in the pre-certification tests. The decision shall be recorded in a traceable manner.

9.5 Layout of quality declaration

The product certificate shall be in accordance with the model included in Annex I/Annex I. The declaration of conformity tank shall be in accordance with the model included in Annex II.

9.6 Nature and frequency of third party audits

The certification body shall carry out surveillance audits on the supplier's site at regular intervals to check whether the supplier complies with his obligations. The Board of Experts decides on the frequency of these audits.

At the time this BRL was validate, the frequency of audits has been determined at 1 audit per 100 non-stationary storage and dispensing installations in accordance with scope 1a and 1 audit per 5 tank containers in accordance with scope 1b, with a maximum of 5 audits per year.

The assessment program on site shall cover at least:

- the product requirements;
- the production process;
- the suppliers IQC scheme and the results obtained from inspections carried out by the supplier;
- the correct marking of the certified products;
- compliance with the required procedures;
- handling of complaints concerning the delivered products.

The results of each audit shall be reported by the certification body in a traceable manner.

9.7 Non conformities

When the certification requirements are not met, measures are taken by the certification body in accordance with the sanctions policy as detailed in the regulation for certification of the certification body.

The regulations for certification can be found at the Kiwa website.

9.8 Report to the Board of Experts

The certification body shall report annually regarding the certification activities performed. This report shall include the following aspects:

- mutations in number of certificates issued (granted / withdrawn);
- number of inspections carried out in relation to the required minimum;
- the results of these inspections;
- the measures imposed in case of shortcomings;
- the complaints received concerning the certified products.

9.9 Interpretation of requirements

The Board of Experts may record the interpretation of requirements of this Evaluation Guideline in a separate interpretation document.

9.10 Specific rules set by the Board of Experts

No specific rules have been laid down by the Board of Experts when validating this Evaluation Guideline.

10 List of referenced documents

10.1 Standards / normative documents

Public law regulations:	Title
ADR	Accord Européen au transport international des marchandises Dangereuses par Route.
AI 5	Working Conditions Legislation information for safe working in confined spaces.
EURAL	European Waste Catalogue.
PGS 30	Publication series 30 "Liquid petroleum products; Above ground storage and dispensing installations".
VLG	Dutch regulation for Transport of dangerous goods by road.
Evaluation Guideline:	Title (Evaluation Guideline for the certification of:)
BRL-K744/01	Metal non-stationary and mobile storage and dispensing installations with a maximum volume of 3 m ³ for above ground storage of liquids version 1 dated 15-5-1996.
BRL-K744/02	Metal non-stationary and mobile storage and dispensing installations with a maximum volume of 3 m ³ for above ground storage of liquids version 2 dated 17-7-2009.
BRL-K744/03	Metal non-stationary and mobile storage and dispensing installations with a maximum volume of 3 m ³ for above ground storage of liquids version 3 dated 1-7-2013.
BRL-K748	Metal drip trays for filling points.
BRL-K758	Coating suitability of metal products to be coated.
BRL-K636	Overfill prevention devices for storage tanks for liquid petroleum fuels.
BRL-K779	Internal coating of steel tanks for flammable liquids.
BRL-K790	Application of coating systems to steel pipes or steel storage tanks for liquids.
BRL-K903	Certification scheme for Installers of Tank Installations (REIT).
BRL-K905	Tank cleaning
BRL-K916	Anti-siphon devices for tank installations.
BRL-K21012	Exterior paint systems for steel above ground storage tanks
BRL-K21013	Container tanks
BRL SIKB 7800	Tank installations (former BRL-K903)
Standards:	Title
ISO 7-1 part 1	Pipe threads where pressure-tight joints are made on the threads – Part 1: Dimensions, tolerances and designation.
NEN-EN 288-1 (withdrawn)	Specification and approval of welding procedures for metallic materials - Part 1: General rules for fusion welding.
NEN-EN 288-2 (withdrawn)	Specification and approval of welding procedures for metallic materials - Part 2: Welding procedure specification for arc welding.
NEN-EN 288-3 (withdrawn)	Specification and approval of welding procedures for metallic materials - Part 3: Welding procedure tests for the arc welding of steels.
NEN-EN 10025-1	Hot rolled products of structural steels - Part 1: General technical delivery conditions.
NEN-EN 10025-2	Hot rolled products of structural steels - Part 2: Technical delivery conditions for non-alloy structural steels.
NEN-EN 10025-3	Hot rolled products of structural steels - Part 3: Technical delivery conditions for normalized / normalized rolled weldable fine grain structural steels.
NEN-EN 10025-4	Hot rolled products of structural steels - Part 4: Technical delivery conditions for thermomechanical rolled weldable fine grain structural steels.
NEN-EN 10025-5	Hot rolled products of structural steels - Part 5: Technical delivery conditions for structural steels with improved atmospheric corrosion resistance.
NEN-EN 10025-6	Hot rolled products of structural steels - Part 6: Technical delivery conditions for flat products of high yield strength structural steels in the quenched and tempered condition.
NEN-EN 10088-1	Stainless steels - Part 1: List of stainless steels.
NEN-EN 10088-2	Stainless steels - Part 2: Technical delivery conditions for sheet / plate and strip of corrosion resisting steels for general purposes.

NEN-EN 10204:2004	Metallic products - Types of inspection documents.
NEN-EN 10241	Steel threaded pipe fittings.
NEN-EN 10242	Threaded pipe fittings in malleable cast iron.
NEN-EN 12285-2	Workshop fabricated steel tanks - Part 2: Horizontal cylindrical single skin and double skin tanks for the aboveground storage of flammable and non-flammable water polluting liquids.
NEN-EN-ISO 1461	Hot dip galvanized coatings on fabricated iron and steel articles - Specifications and test methods.
NEN-EN-ISO 2409	Paints and varnishes – Cross-cut test
NEN-EN-ISO 5817	Welding - Fusion-welded joints in steel, nickel, titanium and their alloys (beam welding excluded) - Quality levels for imperfections.
NEN-EN-ISO 6520-1	Welding and allied processes - Classification of geometric imperfections in metallic materials - Part 1: Fusion welding.
NEN-EN-ISO 8501-1	Preparation of steel substrates before application of paints and related products - Visual assessment of surface cleanliness - Part 1: Rust grades and preparation grades of uncoated steel substrates and of steel substrates after overall removal of previous coatings
NEN-EN-ISO 8501-1	Preparation of steel substrates before application of paints and related products - Visual assessment of surface cleanliness - Informative supplement to Part 1: Representative photographic examples of the change of appearance imparted to steel when blas-cleaned with different abrasives
NEN-EN-ISO 9001	Quality management systems - Requirements.
NEN-EN-ISO 9606-1	Qualification testing of welders - Fusion welding - Part 1: Steels.
NEN-EN-ISO 10675-1	Non-destructive testing of welds - Acceptance levels for radiographic testing - Part 1: Steel, nickel, titanium and their alloys.
NEN-EN-ISO 12944-1	Paints and varnishes - Corrosion protection of steel structures by protective paint systems - Part 1: General introduction.
NEN-EN-ISO 12944-2	Paints and varnishes - Corrosion protection of steel structures by protective paint systems - Part 2: Classification of environments.
NEN-EN-ISO 12944-3	Paints and varnishes - Corrosion protection of steel structures by protective paint systems - Part 3: Design considerations.
NEN-EN-ISO 12944-4	Paints and varnishes - Corrosion protection of steel structures by protective paint systems - Part 4: Types of surface and surface preparation.
NEN-EN-ISO 12944-5	Paints and varnishes - Corrosion protection of steel structures by protective paint systems - Part 5: Protective paint systems.
NEN-EN-ISO 14732	Welding personnel - Qualification testing of welding operators and weld setters for mechanized and automatic welding of metallic materials.
NEN-EN-ISO 15607	Specification and qualification of welding procedures for metallic materials - General rules.
NEN-EN-ISO 15609-1	Specification and qualification of welding procedures for metallic materials - Welding procedure specification - Part 1: Arc welding.
NEN-EN-ISO 15609-2	Specification and qualification of welding procedures for metallic materials - Welding procedure specification - Part 2: Gas welding.
NEN-EN-ISO 15609-3	Specification and qualification of welding procedures for metallic materials - Welding procedures specification - Part 3: Electron beam welding.
NEN-EN-ISO 15609-4	Specification and qualification of welding procedures for metallic materials - Welding procedure specification - Part 4: Laser beam welding.
NEN-EN-ISO 15614-1	Specification and qualification of welding procedures for metallic materials - Welding procedure test - Part 1: Arc and gas welding of steels and arc welding of nickel and nickel alloys.
NEN-EN-ISO 17636-1	Non-destructive testing of welds - Radiographic testing - Part 1: X- and gamma-ray techniques with film.
NEN-EN-ISO 17638	Non-destructive testing of welds - Magnetic particle testing.
NEN-EN-ISO 23278	Non-destructive testing of welds - Magnetic particle testing - Acceptance levels.
NEN-EN-ISO/IEC 17020	Conformity assessment - Requirements for the operation of various types of bodies performing inspection.
NEN-EN-ISO/IEC 17021-1	Conformity assessment - Requirements for bodies providing audit and certification of management systems - Part 1: Requirements.
NEN-EN-ISO/IEC 17024	Conformity assessment - General requirements for bodies operating certification of persons.
NEN-EN-ISO/IEC 17025	General requirements for the competence of testing and calibration laboratories
NEN-EN-ISO/IEC 17065	Conformity assessment - Requirements for bodies certifying products, processes and services.

If no date of issue is mentioned, the current version of the document applies.

Annex I Model product certificate



Product certificate KXXXXXX/XX

Issued *yyyy-mm-dd*

Replaces

page *1 of 2*

Steel non-stationary storage and dispensing installations / tank containers for above ground atmospheric storage of liquids

STATEMENT BY KIWA

With this product certificate, issued in accordance with the Kiwa Regulations for Certification, Kiwa declares that legitimate confidence exists that the products supplied by

<Name supplier>

as specified in this product certificate and marked with the Kiwa[®]-mark in the manner as indicated in this product certificate may, on delivery, be relied upon to comply with Kiwa evaluation guideline BRL-K744/04 " Steel non-stationary storage and dispensing installations / tank containers for above ground atmospheric storage of liquids" dated 01-11-2019 plus amendment dated 01-01-2024.

Applicable for the next scope:

- Scope 1a "Production of steel non-stationary storage- and dispensing installations with a maximum volume of 3 m³".
- Scope 1b "Production of steel tank containers with a volume between 5 and 20 m³".

Ronald Karel
Kiwa

Publication of this certificate is allowed.

Advice: consult www.kiwa.nl in order to ensure that this certificate is still valid.

Kiwa Nederland B.V.
Sir Winston Churchilllaan 273
Postbus 70
2280 AB RIJSWIJK
The Netherlands
Tel. 088 998 44 00
Fax 088 998 44 20
info@kiwa.nl
www.kiwa.nl

Supplier
<name supplier>
<address>
<postal code> <TOWN>
Tel.
Fax
www.
E-mail

**Certification process
consists of initial and
regular assessment
of:**

- quality system
- product

Product certificate

KXXXXXX/XX

Page 2 of 2

Steel non-stationary storage and dispensing installations / tank containers for above ground atmospheric storage of liquids

Technical specification

Product specification (scope 1a/1b)

Specification of certified steel non-stationary storage and dispensing installations / tank containers

Type UN-mark /...../....

--=month () and year (--) (last two digit) of production.

Application and use (scope 1a/1b)

Non-stationary storage and dispensing installations and tank container are intended for use for temporary, non-stationary aboveground storage of liquids.

Marking

The products are marked with the Kiwa quality mark.

Location of the mark: on an identification plate on the outside of the second containment / container at a location that is clearly visible.

Mandatory indications:

- supplier's name or trademark;
- year of construction (will not apply if the tank number indicates this);
- tank number;
- nominal volume in m³;
- UN-mark;
- Inspection date.

Method of marking:

- non-erasable;
- word mark "KIWA".

RECOMMENDATIONS FOR CUSTOMERS

Check on receipt of the tank whether:

- the supplier has delivered in accordance with the agreement;
- the mark and the marking method are correct;
- the products show no visible defects as a result of transport etc.

If you should reject this product on the basis of the above then please contact:

- <Name supplier>
- and, if necessary,
- Kiwa Nederland B.V.

Consult the instructions of the certified company for the correct method of storage, transport and processing.

Annex II Model process certificate

NOT TRANSLATED. WILL BE ISSUED IN DUTCH ONLY, AFTER CONFORMITY WITH THE REQUIREMENTS OF SCOPE 2.

Annex III Model declaration of conformity

Declaration of conformity tank

BRL-K744/04

Steel non-stationary storage and dispensing installations / tank containers
for above ground storage of liquids

Purchaser

Supplier / manufacturer

Tank Supplier B.V.
Street 1
1234 AB ERGENS
Tel: 0123-112200
Fax: 0123-112233
Email: info@tankleverancier.nl

Registration number
Kiwa registration no..

Registration date
??-??-20??

Tank number:
Tank no.

Scope:
Scope 1a
Scope 1b

Tank data

Year of manufacture (yyyy)
Volume (l)

Length (mm)
Width/diameter (mm)
Height (mm)

Tank type Single-walled / Double-walled
Material Steel / Stainless steel
External coating* C3
Internal coating (option)

* at least in accordance with atmospheric corrosivity category C3 in accordance with NEN-EN-ISO 12944

Description of scopes:

1a: Steel non stationary storage and dispensing installations with a maximum volume of 3 m³

1b: Steel non stationary tank containers with a volume from 5 to 20 m³

Declaration by Kiwa

Based on pre-certification tests as well as periodic inspections carried out by Kiwa, the tank referred to in this declaration of conformity tank can be considered to be in compliance with the Kiwa Evaluation Guideline BRL-K744.

Declaration by supplier / manufacturer

The supplier / producer declares that the fabrication and testing of this tank is accordance with the Kiwa Evaluation Guideline BRL-K744.

General

It is recommended to periodically check a steel non stationary storage and dispensing installation in accordance with BRL-K744 scope 2. Users are responsible for the execution of this periodically check within the set period. This non stationary storage and dispensing installation is not intended for stationary storage longer than 6 months at the same location. When a longer period is needed, a stationary installation must be installed.

Recommendations for customers

Check at the time of delivery whether:

- The tank serial number corresponds to the number at this declaration of conformity tank.
- The tank has sustained no visible damage during transport.

If you should reject a product on the basis of the above, please contact:

1. The supplier of the tank.
2. Kiwa Nederland B.V.



Kiwa Nederland B.V.

Sir Winston Churchill-laan 273
P.O. Box 70
2280 AB Rijswijk
The Netherlands
Telephone: 088 998 44 00
Internet: www.kiwa.nl

A copy of this declaration of conformity tank is for the local authorities, owner, supplier, Kiwa

Validation date ??-??-20??

Registration number

Annex IV Model report check

NOT TRANSLATED. WILL BE ISSUED IN DUTCH ONLY.

Annex V Reference drawing scope 1a

(Cylindrical)

Construction and measurements of a cylindrical model scope 1a

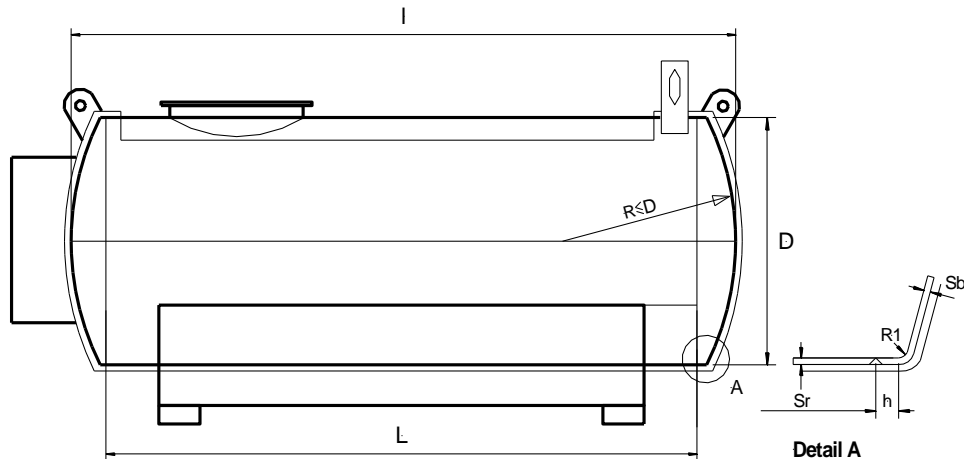

Figure Annex 5.1: Example cylindrical tank scope 1a

- D = Diameter of the shell, $800 \geq D \leq 1600$ mm
- l = Overall length of the tank (including dished ends)
- L = Length of the tank without dished ends
- S_r = Nominal wall thickness of the shell, minimal 3 mm
- S_b = Nominal wall thickness of dished end, minimal 3 mm
- R = Crown radius, $R \leq D$
- R_1 = Knuckle radius, $R_1 \geq \sqrt{D}$
- h = Length of the straight flange of dished end, $h \geq 20$ mm

Remark: Figure Annex 5.1 is an example of a tank provided with saddle support. In accordance with ADR a tank support in longitudinal direction of the tank is also possible.

Length of cylindrical tank

The length of the tank without dished ends (L) is the overall length (l) minus the length of the dished ends.

The maximum length of the tank is restricted by the diameter and maximum capacity.

Shell (cylindrical tank scope 1a)

Cross seams shall be not allowed. Longitudinal welds shall be not allowed in the bottom part of the tank. The minimum distance between longitudinal welds and manhole neck is 25 mm.

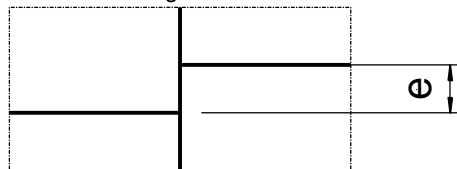

Figure Annex 5.2: Distance longitudinal welds.

- e = Shell plate joint shall be offset, having a minimum distance e of five times the wall thickness (S_r) but not less than 25 mm

Annex VI Reference drawing scope 1a (Non-cylindrical)

Construction and measurements of a non-cylindrical model scope 1a

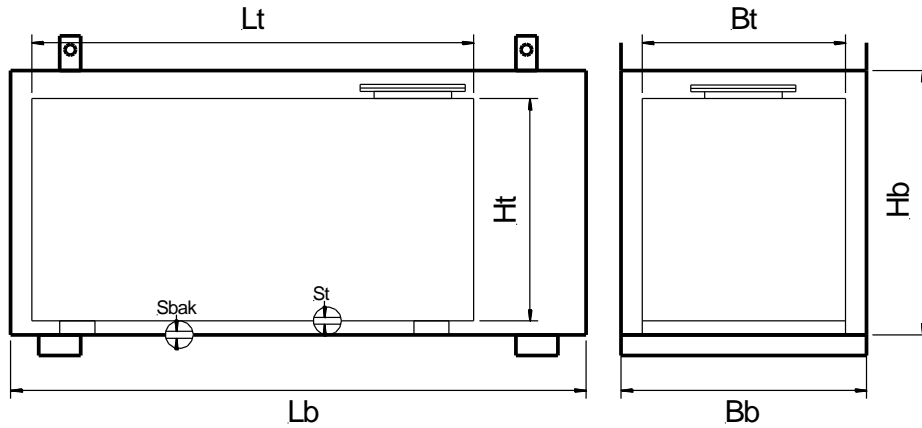

Figure Annex 6: Example non-cylindrical tank scope 1a

- L_t = Total length tank
- B_t = Total width tank
- H_t = Total height tank
- L_b = Total length second containment
- B_b = Total width second containment
- H_b = Total height second containment (excluding supports)
- S_t = Nominal wall thickness tank (bottom, walls and top), minimal 3 mm
- S_{bak} = Nominal wall thickness second containment (cover second containment excluded), minimal 3 mm

Length-width-height non-cylindrical tank

There are no specific requirements for length-width-height of non-cylindrical tanks.

Remark: The length-width-height proportions could have a negative effect on the UN type approval tests.

Annex VII Reference drawing interstitial space

Construction and measurements interstitial space scope 1a

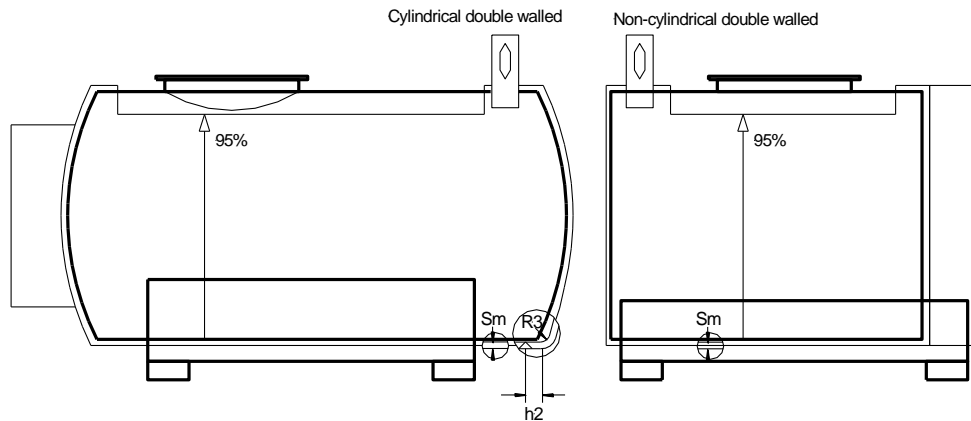

Figure Annex 7: Example interstitial space tank scope 1a

- S_m = Nominal wall thickness outer skin, minimal 3 mm
- R_3 = Knuckle radius dished end, no specific requirements
- h_2 = Length of the straight flange of dished end, no specific requirements

Outer skin specification

The outer skin shall be strong enough to equalize the load on the saddles to inner tank.

The distance between the outer skin to the inner tank must be kept as small as possible. Maximum distance is limited to 1,5 x the wall thickness of the outer skin.

At places where the outer skin is connected to the inner tank, the leak detection medium must have the possibility to move freely.

Comment: The function of the outer skin around the inner tank, is meant to be as a part of the leak detection system. Most important purpose of the outer skin, is to create a interstitial space between the inner tank and the outer skin for detecting leakages in both inner tank and outer skin.

The minimum distance in longitudinal direction between the circumference welds of the inner tank and outer skin shall be less than 20 mm.

The minimum distance in circumference direction between the longitudinal welds of the inner tank and outer skin shall be less than 20 mm.

The overlap of sheets of the outer skin (shell) and outer dished head shall be less than 5 mm.

The overlap of mutual sheets of the outer skin shall be less than 5 mm.

Annex VIII Reference drawing scope 1b

Construction and measurements of a tank container scope 1b

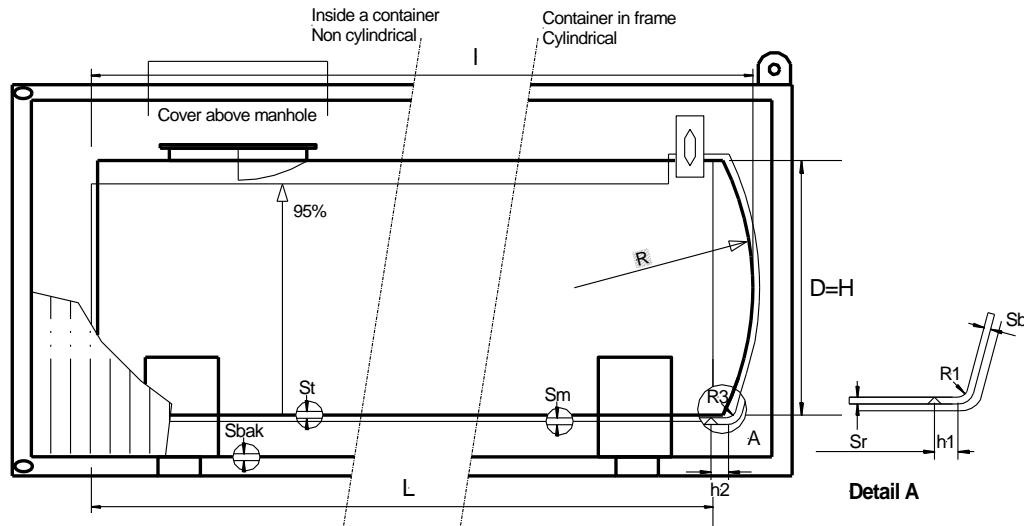

Figure Annex 8.1: Example tank container scope 1b

- $D=H$ = Diameter shell = height of the tank, $800 \geq D \leq 2500$ mm
- I = Overall length tank (for cylindrical tanks including dished ends)
- L = (Cylindrical) Length of the tank without dished ends (not applicable for non-cylindrical tanks)
- S_r = Nominal wall thickness of the shell, see table
- S_t = Nominal wall thickness of the tank (bottom, walls and top), see table
- S_b = Nominal wall thickness of the bottom, minimal 3 mm
- S_{bak} = Nominal wall thickness of second containment or walls of the container, minimal 3 mm
- S_m = Nominal wall thickness of outer skin, minimal 3 mm
- R = Crown radius, $R \leq D$
- R_1 = Knuckle radius, $R_1 \geq D/30$
- R_3 = Knuckle radius dished end, no specific requirements
- h_1 = Length of the straight flange of dished end, $h_1 \geq 20$ mm
- h_2 = Length of the straight flange of dished end, no specific requirements

Height tank

Maximum height of the tank (H) is 2500 mm or is limited by the distance needed for inspection of the top part of the tank in the case of installation inside a container.

Length cylindrical tank

The length of the tank without dished ends (L) is the overall length (I) minus the length of the dished ends.

The maximum length of the tank is restricted by the diameter and maximum capacity.

Dished heads cylindrical tank

Dished ends shall be in accordance with EN 12285-2 the proto type approval, if a cylindrical tank is used.

Shell (cylindrical tank scope 1b)

Cross seams shall be not allowed. Longitudinal welds shall be not allowed in the bottom part of the tank. The minimum distance between longitudinal welds and manhole neck is 25 mm.

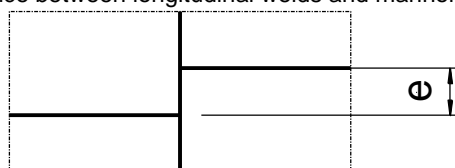

Figure Annex 8.2: Distance longitudinal welds

e = Shell plate joint shall be offset, having a minimum distance e of five times the wall thickness (S) but not less than 25 mm

Annex IX IQC scheme (Example)

IV.1. IQC scheme

The supplier / tank manufacturer shall have an internal quality control scheme (IQC scheme) implemented in his factory. This IQC scheme is an overview of the internal and quality controls that the supplier / tank manufacturer performs during production. The IQC scheme contains a schematic overview of all controls that relate to the production of non-stationary storage and dispensing installations and tank container.

The IQC scheme consists of the following components:

- Which inspections are carried out by the supplier / tank manufacturer.
- What is specifically inspected.
- Which test method is used.
- What is the inspection frequency.
- The method of registration regarding the inspection performed and the results obtained.

Example

B Inspection during production

No.	Description	Inspection aspects	Inspection method	Instruction no.	Inspection frequency	Inspection registration
1	Cutting of plates	Instruction / Drawing				
1.1		Dimensions	(Inspection equipment)	(Procedure)	(Each plate)	(Checklist ...).
1.2		Bottom circumference	(Inspection equipment)	(Procedure)	(Each plate)	(Checklist ...).
					
2	Rolling of plates	Instruction / Drawing				
2.1		<i>Dimensions after rolling</i>	(Inspection equipment)	(Procedure)	(Each plate)	(Checklist ...).
3						
3.1						
3.1						
4						
4.1						
4.1						
					

The final IQC scheme is a proprietary scheme. After all, each company has its own working practises and methods. It is therefore important that the IQC scheme corresponds with the working practices and methods within the company, but at the same time is in conformance with the requirements of BRL-K744.

IV.2. Checklist

A checklist contains a registration of all relevant production steps, checks and inspections. The checklist is traceable to the container tank to be produced and is kept up to date during production by the employees of the tank supplier / tank manufacturer. The checklist also gives the production stage of the tank. The term production card can also be used instead of checklist.

Example of a checklist

Supplier / tank manufacturer

Order number:

Production number:		Client:		Drawing no.:	
Tank capacity (litres):		Tank type:		Material tank:	
Tot. length tank (mm):		Cyl. length (mm):		Diameter tank (mm):	
Wall thickness tank:		Wall thickness outer skin:			
Manhole dimensions:					
No. of lifting lugs:		Size of lifting lug hole:			
Connections:	Filling line Vent Suction Fluid level indicator Extra connections				DN 80 DN

Check internal quality department

<input type="checkbox"/> Internal	Status:	Employee(s):	
<input type="checkbox"/> Kiwa	Date:		

Description	Accepted			Signature	Name of employee	Remarks
	Y	N	N.A.			
1.0 Cutting of plate	<input type="checkbox"/>	<input type="checkbox"/>	<input type="checkbox"/>			Charge:
2.0 Bending of plate material	<input type="checkbox"/>	<input type="checkbox"/>	<input type="checkbox"/>			
3.0 Etc.	<input type="checkbox"/>	<input type="checkbox"/>	<input type="checkbox"/>			
	<input type="checkbox"/>	<input type="checkbox"/>	<input type="checkbox"/>			

IV.3. Quality system

The supplier / tank manufacturer can also set up a documented quality system. If an organization has a quality system based on NEN-EN-ISO 9001, then where possible, reference can be made to procedures or instructions that form part of this quality system.

Kiwa can provide the supplier / tank manufacturer with an example of a quality system.