

AR 1

May 2024 Dutch version

Approval requirement 1

Bendable hose assemblies



Trust
Quality
Progress

Foreword Kiwa

This, translated from English, approval requirement (AR), is approved by the Board of Experts (BoE) GASTEC QA. in which relevant parties in the field of gas related products are represented. This Board of Experts supervises the certification activities and where necessary require the GASTEC QA approval requirement to be revised. All references to Board of Experts in this GASTEC QA approval requirement pertain to the above-mentioned Board of Experts.

This, translated from English, AR will be used by Kiwa Nederland BV in conjunction with the GASTEC QA general requirements and the KIWA regulations for certification.

In this AR is established which requirements a product and the requestor/ certificate holder of the GASTEC QA product certificate should meet and the matter to which Kiwa evaluates this.

Kiwa has a method which is established in the certification procedure for the execution of:

- The investigation for provisioning and maintaining a GASTEC QA product certificate based on this AR.
- The periodic evaluations of the certified products for the purpose of maintaining a provided GASTEC QA product certificate based on this AR.

This, translated from English, AR, is used as supporting document. In case of doubt of interpretation of this AR, the English version is leading.

Kiwa Nederland B.V.

Wilmersdorf 50

Postbus 137

7300 AC Apeldoorn

The Netherlands

Tel. +31 88 998 33 93

Fax +31 88 998 34 94

info@kiwa.nl

www.kiwa.nl

© 2024 Kiwa Nederland B.V.

All rights reserved. No part of this document may be reproduced, stored in a database or retrieval system, or published, in any form or in any way, electronically, mechanically, by print, photoprint, microfilm or any other means without prior written permission from the publisher.

The use of this approval requirement by third parties, for any purpose whatsoever, is only allowed after a written agreement is made with Kiwa to this end

Table of Contents

Foreword Kiwa	1
Table of Contents	2
1 Introduction	4
1.1 General	4
1.2 Scope	4
2 Definitions	5
3 Material and product requirements	6
3.1 Material	6
3.2 Construction	6
3.3 Dimensions	7
3.3.1 Wall thickness	7
3.3.2 Nominal inner diameter	7
3.3.3 Length	7
3.3.4 Bendable length	7
4 Performance requirements and test method	8
4.1 General	8
4.2 Resistance against stress corrosion	8
4.2.1 Test method (magnesium chloride)	8
4.3 Uniform corrosion resistance	9
4.3.1 Test method	9
4.4 Leak tightness	9
4.4.1 Test method	9
4.5 Determination of pressure loss	9
4.5.1 Test method	9
4.6 Resistance against internal pressure	10
4.6.1 Test method	10
4.7 Resistance to pull out	10
4.7.1 Test method	10
4.8 Resistance against bending	11
4.8.1 Test method	11
4.9 Strength of fittings	12
4.9.1 Test method	12
4.10 Resistance against falling loads	12
4.10.1 Test method	12
4.11 Resistance against repeated bending of the coupling	13

4.11.1	Test method	13
4.12	Self-extinguishing test method	14
5	Marking, instructions and packaging	15
5.1	Marking	15
5.2	Instructions	15
5.3	Packaging	15
6	Quality system requirements	16
7	Summary of testing and control	17
7.1	Test matrix	17
8	List of referenced documents	18
8.1	Standards / normative documents	18
8.2	Source of informative documents	18

1 Introduction

1.1 General

This GASTEC QA approval requirement (AR) in combination with the GASTEC QA general requirements, is applied by Kiwa as the basis for the issuing and maintaining the GASTEC QA product certificate for bendable hose assemblies.

With this product certificate, the certificate holder can demonstrate to his or her customers that an expert independent organization monitors the production process of the certificate holder, the quality of the product and the related quality assurance.

Next to the requirements established in this AR and the general requirements, Kiwa has additional requirements in the sense of general procedural requirements for certification, as laid down in the internal certification procedures.

This GASTEC QA approval requirement replaces version of September 2018.

List of changes

- These approval requirements have been fully reviewed textually.
- Change of paragraphs

The product requirements have not changed.

1.2 Scope

These approval requirements describe the requirements for stainless steel bendable hose assemblies with a nominal internal 10 mm up to and including 25 mm diameter for use in installation for natural gas with a pressure of no more than 200 mbar in accordance with the NPR 3378-11 Code of Practice.

2 Definitions

In this approval requirement, the following terms and definitions are applicable:

Natural gas: 2nd family gas in accordance with EN 437.

Bendable hose assembly: Easy to bend corrugated stainless-steel pipe with at least one detachable coupling.

Board of Experts (BoE): The Board of Experts GASTEC QA.

Bendable length: the corrugated section of the corrugated metal hose assembly.

Maximum operating pressure (MOP): Maximum pressure that a component is capable of withstanding continuously in service under normal operating conditions.

Leak tightness: A product is considered as being leak tight when the following requirements are met:

- If the test fluid is a liquid, visually detectable leakage is not permitted.
- If the test fluid is a gas:
 - o When submerged in water no bubbles are permitted.
 - o When using a leak detection fluid, no continuous formation of bubbles is permitted.

Stress corrosion: Type of corrosion caused by control stresses (via operations) and the simultaneous action of a corrosive medium. Stress corrosion cracking is a consequence of stress corrosion cracking.

Uniform corrosion: Type of corrosion due to a natural interaction between a material and its environment. Oxygen corrosion is the most visible form of corrosion.

See also the definitions mentioned in the GASTEC QA general requirements.

3 Material and product requirements

This chapter contains the requirements for the properties of the raw materials, materials and semi-products used during the production of the products to be certified under this AR (e.g., support bushes).

3.1 Material

The used metals shall be proven to be suitable for the application (pressure, ambient temperature, corrosion resistance and long-term behaviour). The suitability of the metal can be proven through a risk analysis or referral to the relevant product standards (for example, ISO 10380) of comparable products in which the relevant material is prescribed.

The material shall be specified in accordance with the relevant material standardizations.

If plastic has been used for the protective layer, it shall be self-extinguishing, and it may not negatively affect the metals.

Rubber seals shall comply with the EN 549 standard with a temperature class of at least A2.

3.2 Construction

The bendable hose assembly may not show any dents, holes, cracks, fractures or any other shortcomings.

The bendable hose assembly shall be provided with a detachable coupling on at least one side to connect to the gas valve (connection valve) in accordance with the figure below.

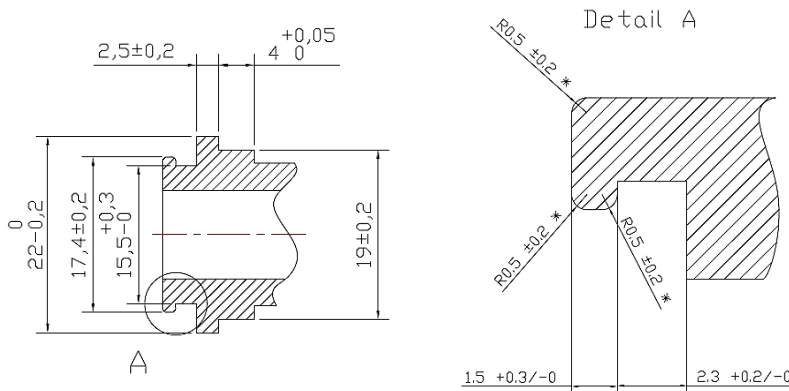

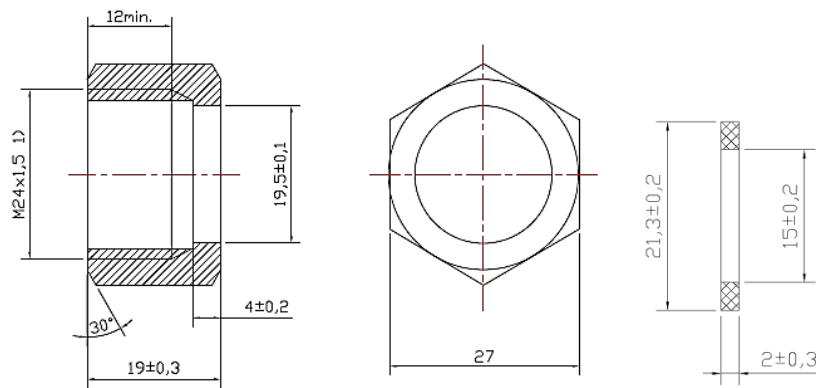

If the bendable hose assembly is provided with a detachable coupling on one side, the coupling on the other side shall comply with the relevant GASTEC QA approval requirements or, if no approval requirements are available, the relevant national or international standards.

If the coupling has spanner flats, the spanner width shall be in accordance with the series specified in the ISO 4032.

3.3 Dimensions

3.3.1 Wall thickness

The wall thickness of the bendable hose assembly shall not be smaller than 0.25 mm at any point. The thickness of any protective layer is not included in this.

3.3.2 Nominal inner diameter

The nominal inner diameter of the bendable hose assembly shall have been selected from the following series:

- 10 mm (3/8")
- 13 mm (1/2")
- 20 mm (3/4")
- 25 mm (1")

3.3.3 Length

The length of the bendable hose assembly shall be between 200 mm and 1000 mm with a tolerance of +20 mm.

Lengths longer than 1 meter are permitted with additional specification on the packaging and/or manual.

3.3.4 Bendable length

The bendable length shall at least be 10 times the nominal inner diameter.

4 Performance requirements and test method

This chapter contains the performance requirements and associated test methods that the products shall meet. This chapter also specifies the limit values, if applicable.

4.1 General

All tests shall be performed at an ambient temperature of 23 ± 5 °C on samples with a length of 300 mm with couplings unless stated otherwise. 1 bendable hose assembly shall be used per test unless specified otherwise.

Leak tightness tests shall be performed using air.

No deformation or damage may occur to the product during testing.

4.2 Resistance against stress corrosion

All parts shall be free of stress corrosion.

The magnesium chloride test in accordance with paragraph 4.2.1 shall be used for stainless steel components. After exposure to the magnesium chloride solution, no cracks shall be observed when assessing visually with a 5 times magnification.

Part made from copper alloys shall be tested by an ammonium chloride test according to ISO 6957 (pH 9,5). No visual signs of cracks shall be observed with a magnification of 10 to 15 times.

4.2.1 Test method (magnesium chloride)

The test shall be performed on a bendable hose assembly without a protective layer. The bendable hose assembly shall be degreased using acetone and shall be bent once over an angle of 90° with a radius in accordance with table 1. The bendable hose assembly shall be filled with glass balls. The ends of the bendable hose assembly shall be sealed to ensure the glass balls cannot fall out of the bendable hose assembly.

Inner diameter (mm/inch)	R (mm)	d (mm)
10 (3/8")	25	13
13 (1/2")	25	16
20 (3/4")	35	21
25 (1")	55	27

Table 1

Dissolve 1000 g $MgCl_2 \cdot 6H_2O$ per 500 ml distilled water, or proportional amounts thereof. There shall be sufficient fluid to completely immerse the assembly.

Heat a vessel to 130 ± 2 °C and place the tube in the fluid for 108 hours let the fluid cool down to $70^\circ C \pm 2$ °C and leave the tube for 60 hours.

It can be necessary that a small amount of magnesium chloride or distilled water must be added in order to reach the 130°C. Make sure that the heating takes place uniformly (avoid bumps and jolts).

The visual assessment of sample takes place with the aid of a 5 times magnifying glass.

4.3 Uniform corrosion resistance

All parts shall be resistant against uniform corrosion. Parts made by a type of Austenitic RVS 300 series are exempt of this requirement due to the material characteristics related to the requirement of uniform corrosion.

4.3.1 Test method

All other metal parts shall be assessed on uniform corrosion by performing the salt spray test according to ISO 9227, with a liquid according to paragraph 5.2.2 and a test duration of 168h.

The bendable hose assemblies will be exposed to the salt spray test unassembled.

After completion of the salt spray test, the bendable hose assembly will be assembled, and the leak tightness will be assessed according to paragraph 4.4. The sample will pass if the product is mountable and leak tight.

4.4 Leak tightness

The bendable hose assembly shall be leak tight for 300 seconds with an internal pressure of 300 mbar.

4.4.1 Test method

The bendable hose assembly shall be sealed on one side and the air pressure shall be increased up to 300 mbar on the other side. No leakage shall be observed for 300 seconds.

4.5 Determination of pressure loss

The measured flow rate (m³/h standard) at an inlet pressure of 25 mbar shall match the table below. At this flow rate the pressure loss over the bendable hose assembly shall not be more than 0,9 mbar.

Inner diameter (mm/inch)	Air flow rate (m ³ /h standard)
10 (3/8")	1
13 (1/2")	2,2
20 (3/4")	5,2
25 (1")	8,4

Table 2

4.5.1 Test method

A set-up in accordance with figure 1 shall be used to determine the flow rate and the loss of pressure over the bendable hose assembly. The air flow rate shall be set according to table 2 by using the control valve on the outlet side. The inlet pressure shall be 25 mbar.

The pressure loss shall be determined for all bendable hose assembly diameters.

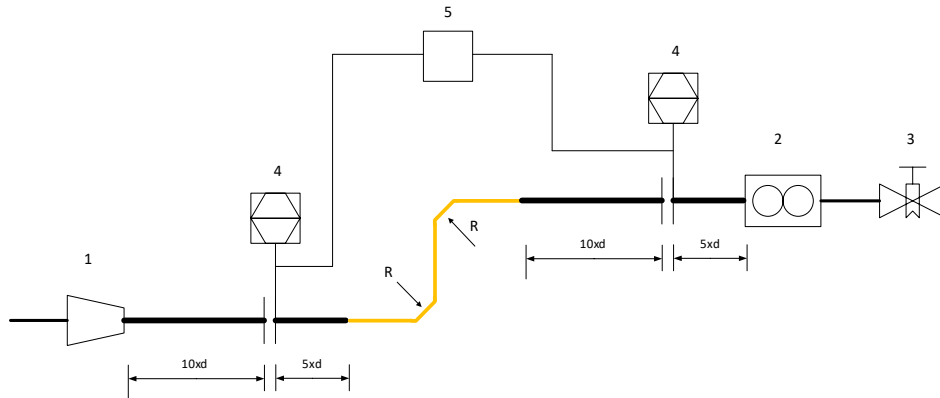

Figure 1

- 1 = inlet pressure regulator
- 2 = flow meter
- 3 = control valve outlet
- 4 = pressure meter
- 5 = pressure differential meter

4.6 Resistance against internal pressure

The bendable hose assembly shall be able to withstand an internal water pressure of 16 bar during 300 seconds without presenting leaks.

4.6.1 Test method

The bendable hose assembly shall be fully filled with water ensuring that all air has been removed. The internal water pressure of the bendable hose assembly shall be 16 bar and it shall be maintained for 300 s.

Check for leaks during the test.

4.7 Resistance to pull out

The bendable hose assembly shall be able to withstand a tensile load of 140 N per mm of inner diameter in the lengthwise direction without presenting leaks.

4.7.1 Test method

The couplings of the bendable hose assembly shall be connected to a traction device. The internal air pressure of the bendable hose assembly shall be increased up to 300 mbar.

A tensile force shall be exercised on the bendable hose assembly by using a traction device during 300 s that matches 140 N per mm of the inner diameter of the bendable hose assembly. The pressure shall be maintained during the test.

Check for leaks during the test.

4.8 Resistance against bending

After having been stretched by 15% of the flexible section in the lengthwise direction a bendable hose assembly shall be able to be bend 30 times over an angle of 360° without presenting leaks.

4.8.1 Test method

A bendable hose assembly with a length of 600 mm shall be permanently stretched by 15% in the lengthwise direction (of the flexible section) and connected to a gas pipe in accordance with figure 2. 2 mandrels (D) shall be installed on both sides of the fastening on the gas pipe (E) with a d diameter in accordance with the table below.

Inner diameter	d in mm
10 mm (3/8")	25
13 mm (1/2")	25
20 mm (3/4")	35
25 mm (1")	55

Table 3

The horizontal center line of the mandrels shall be located at the first full corrugation crest. The distance of the vertical center lines of the mandrels when compared to the center line of the gas pipe shall be such that the mandrels touch the corrugation crest of the bendable hose assembly as closely as possible without clamping.

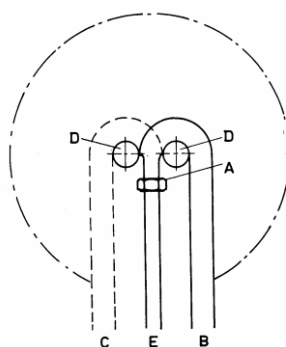

Figure 2

- A = fixing point gas pipe;
- B = starting position;
- C = position after bending;
- D = mandrels;
- E = gas pipe

Next, the bendable hose assembly shall be bent in the start position indicated by the drawn lines and, subsequently, the free end shall be bent from position B to position C through the line-dot-circle arch.

Subsequent, the bendable hose assembly shall again be bent from position C to position B. The movement from B to C or from C to B is deemed to be one bending instance; one bending instance shall be performed in approximately 10 seconds at a uniform speed.

The bendable hose assembly shall touch the mandrel over 180° with regard to every bending instance.

Check the leak tightness of the bendable hose assembly in accordance with paragraph 4.3 after 30 bending instances.

4.9 Strenght of fittings

Couplings with a flat gasket shall be able to resist torsion with a moment of 3.5 Nm per mm of inner diameter of the bendable hose assembly without presenting leaks or deformation.

4.9.1 Test method

The coupling of the bendable assembly shall be installed on a suitable counterpart component. The coupling shall be tightened with a moment that matches 3.5 Nm per mm of the inner diameter of the bendable hose assembly.

Check leak tightness in the installed state in accordance with paragraph 4.3. Check the fitting visually for deformation.

4.10 Resistance against falling loads

The bendable hose assembly shall be able to withstand a 10 kilograms weight falling from a height in accordance with table 4 that is directed perpendicularly to the center line of the bendable hose assembly without presenting cracks or leaks.

Inner diameter	Height in mm <i>Calculated till the flat surface</i>
10 mm (3/8")	400
13 mm (1/2")	600
20 mm (3/4")	800
25 mm (1")	1000

Table 4

4.10.1 Test method

The bendable hose assembly of paragraph 4.8 shall be positioned on a horizontally flat surface.

Next, allow a 10 kilograms weight to fall freely on the bendable hose assembly from a height in accordance with table 2 and do it in such a way that the bendable hose assembly is hit uniformly over a length of 70 mm.

The 70 mm length can be achieved by positioning a square wooden block perpendicularly to the lengthwise direction of the bendable assembly to start from the 2nd corrugation crest from the coupling.

After the test, cracks must not be discernible, and the bendable hose assembly shall be checked for leak tightness in accordance with paragraph 4.3.

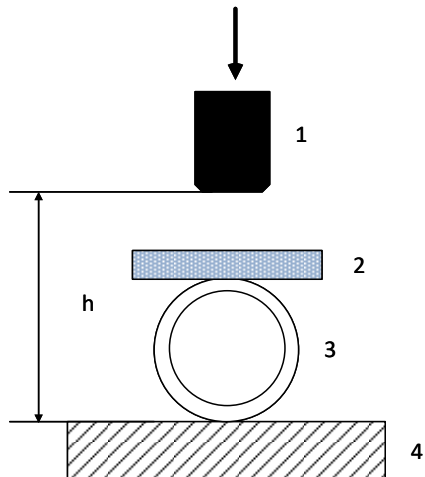

Figure 3

- 1 = weight 10 kg
- 2 = plywood block 70 mm length, thickness 30 mm
- 3 = hose assembly
- 4 = flat surface
- h = height according to table 4

4.11 Resistance against repeated bending of the coupling

The bendable hose assembly shall be able to withstand repeated bending under different angles without presenting leaks.

4.11.1 Test method

A bendable hose assembly with a 600 mm length shall be installed using an appliance coupling on a gas pipe. The bendable hose assembly shall be clamped on the side of the appliance coupling in such a manner that the distance from the top side of the clamping to the connection of the coupling equals the inner diameter of the bendable hose assembly.

The gas pipe is used as a lever to load the connection of the bendable hose assembly with the coupling over an angle of 60° with the center line of the bendable hose assembly. The bendable hose assembly shall then be returned to its starting position and loaded over an angle of 60° in the opposite direction with the prior load. The movement of the gas pipe shall be within one flat plane.

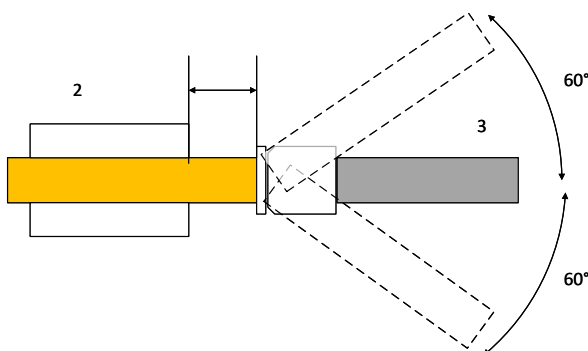

This test shall be repeated in a 45° plane turned clockwise with the 1st plane. The load over an angle of + 60° to – 60° in a plane turned over an angle of 45° clockwise shall be performed 8 times.

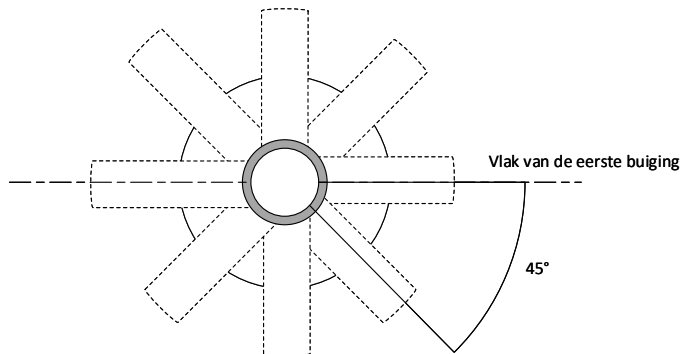

Next, the other side of the bendable hose assembly shall be tested.

After the test, the bendable hose assembly shall be checked for leak tightness in accordance with paragraph 4.3.

4.12 Self-extinguishing test method

The plastic of the protective layer shall be heated by the discoloured flame of a fully lit Bunsen burner with a load of approximately 1.8 kW until flames can be observed. After the Bunsen burner is removed, the flames shall extinguish.

5 Marking, instructions and packaging

5.1 Marking

The product shall be marked with the following information:

- Name or identification marking of the supplier.
- Type designation
- Year and month of manufacture
- GASTEC QA or the GASTEC QA logo

The application method may not negatively affect or damage the corrugated section of the hose assembly.

5.2 Instructions

The product shall have Dutch installation instructions. At least the following topics shall have been included in these instructions:

- Prevent all damage during installation activities.
- Ensure that the hose assembly cannot be twisted.
- Lay the hose assembly in such a way that no sharp kinks occur.
- A diagram with an example or examples on how the installation shall be performed.
- The appliance load for which the hose assembly is suitable.

The instructions may be specified on the packaging.

5.3 Packaging

Every bendable hose assembly shall be protected against possible damage during storage and transport through suitable packaging.

If the length of the product is longer than 1 meter, the following text shall be specified on the packaging: bendable hose assemblies longer than 1 meter may only be used with regard to gas-fired decorative appliances'.

6 Quality system requirements

The requirements for the quality system are described in the GASTEC QA general requirements. An important part of this are the requirements for drawing up a risk analysis (e.g., an FMEA) of the product and the production process in accordance with chapters 3.1.1.1 and 3.1.2.1. This risk analysis shall be available for inspection by Kiwa.

7 Summary of testing and control

This chapter provides a summary of the following tests:

- The initial evaluation test;
- The periodic product verification test

7.1 Test matrix

Description of requirement	Clause	Test within the scope of		
		Initial product assessment	Product verification Verification	Frequency
Material	3.1	X		
Construction	3.2	X		
Dimensions	3.3	X	X	1x/year
Wall thickness	3.3.1	X	X	1x/year
Nominal inner diameter	3.3.2	X		
Length	3.3.3	X		
Bendable length	3.3.4	X		
Resistance against stress corrosion	4.2	X	X	1x/year
Uniform corrosion resistance	4.3	X	X	1x/year
Leak tightness	4.4	X	X	1x/year
Determination of pressure loss	4.5	X		
Resistance against internal pressure	4.6	X		
Resistance to pull out	4.7	X	X	1x/year
Resistance against bending	4.8	X	X	1x/year
Strength of fittings	4.9	X		
Resistance against falling loads	4.10	X		
Resistance against repeated bending of the coupling	4.11	X		
Self-extinguishing testing method	4.12	X		
Marking	5.1	X	X	1x/year
Instructions	5.2	X		
Packaging	5.3	X		

8 List of referenced documents

8.1 Standards / normative documents

All normative references in this approval requirement refer to the editions of the standards as mentioned in the list below.

ISO 10380: 2012	Pipework – corrugated metal hoses and hose assemblies
ISO 4032: 2023	Fasteners - Hexagon regular nuts (style 1)
ISO 6957: 1988	Copper alloys – ammonia tests for stress corrosion resistance
ISO 9227: 2017	Corrosion tests in artificial atmospheres – Salt spray tests

8.2 Source of informative documents

EN 437: 2021	Test gases- test pressure – appliance categories
EN 549: 2019+A1:2023	Rubber materials for seals and diaphragms for gas appliances and gas equipment
NPR 3378-11: 2018	Code of Practice gas installations – Section gas pipe work – Part 11: connecting pipe work and taps
General requirements GASTEC QA	