

Owner of the declaration: Vaillant GmbH

Publisher: Kiwa-Ecobility Experts

Programme operator: Kiwa-Ecobility Experts

Registration number: EPD-Kiwa-EE-000389-EN

Issue date: 01.07.2024

Valid until: 01.07.2029



aroTHERM plus 12 kW & Hydraulic Station

The aroTHERM plus 12 kW is also known as "VWL 125/6 A S2 (mono 400 V)" and "VWL 125/6 A 230V", which is the outdoor unit of an air-to-water heat pump with monobloc technology. The Hydraulic Station is also known as "VWZ MEH 97/6", which is the indoor unit of an air-to-water heat pump with monobloc technology.

1. General information

Vaillant GmbH

Programme operator:

Kiwa-Ecobility Experts
Kiwa GmbH, Ecobility Experts
Wattstraße 11-13
13355 Berlin
Germany

Registration number:

EPD-Kiwa-EE-000389-EN

Product category rules:

PCR A: General Product Category Rules for Construction Products from the EPD program of Kiwa-Ecobility Experts; Version 2.1
PCR Guidance-Texts for Building-Related Products and Services: From the range of Environmental Product Declarations of Institute Construction and Environment e.V. (IBU) – Part B: Requirements on the EPD for HVAC Appliances (18.08.2023)

Issue date:

01.07.2024

Valid until:

01.07.2029



Raoul Mancke
(Head of programme operations, Kiwa-Ecobility Experts)

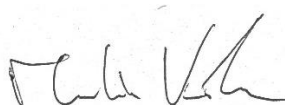

Martin Koehrer
(Verification body, Kiwa-Ecobility Experts)

aroTHERM plus 12 kW & Hydraulic Station

Owner of the declaration:

Vaillant GmbH
Berghäuser Straße 40
42859 Remscheid
Germany

Declared product / declared unit:

1 piece of heat pump system

Scope:

This Environmental Product Declaration (EPD) is based on the life cycle assessment (LCA) of the aroTHERM plus 12 kW (“VWL 125/6 A S2 (mono 400 V)” and “VWL 125/6 A 230V”) and the Hydraulic Station (VWZ MEH 97/6) produced by Vaillant. The used geographical area is Europe.

The owner of the declaration shall be liable for the underlying information and evidence. Kiwa-Ecobility Experts shall not be liable with respect to manufacturer information, life cycle assessment data and evidences.

Verification:

The European standard EN 15804+A2:2019 serves as the core PCR.

Independent verification of the declaration and data according to ISO 14025:2010.

internally

externally

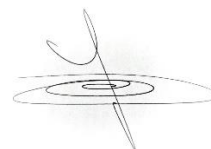

Anne Kees Jeeninga
(Third-party verifier)

2. Product

2.1 Product description

In Figure 1 the structure of a typical heat pump system with monobloc technology is shown.

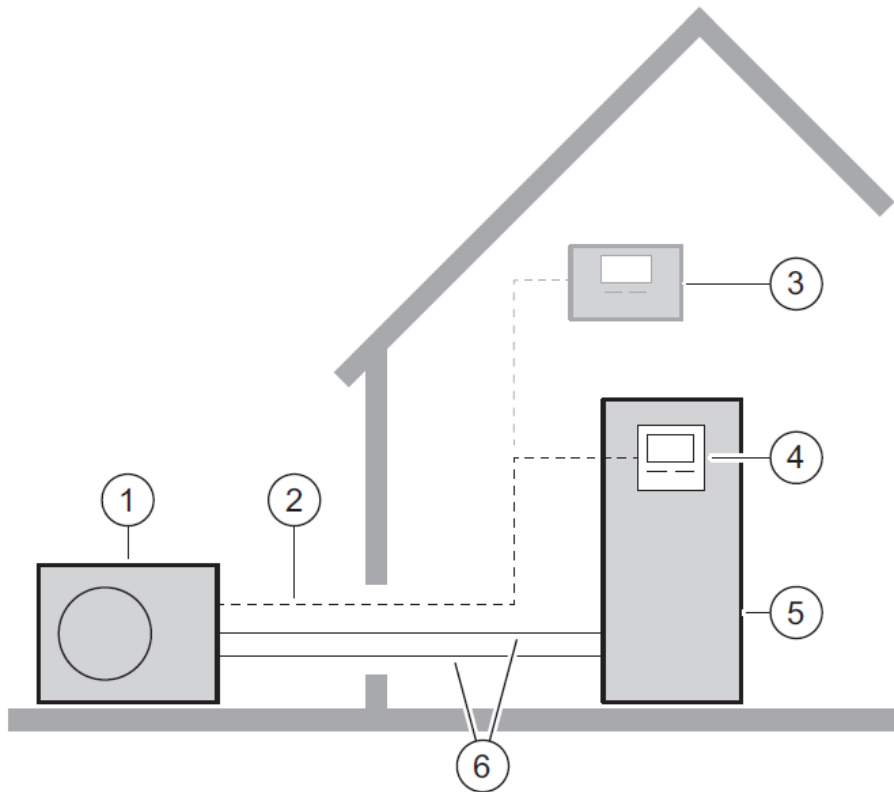

Figure 1: Structure of a typical heat pump system with monobloc technology

It contains the following components:

- (1) Outdoor unit
- (2) eBUS line
- (3) System controller
- (4) Indoor unit controller
- (5) Indoor unit with hot water tank
- (6) Heating circuit

The aroTHERM plus 12 kW is also known as “VWL 125/6 A S2 (mono 400 V)” and “VWL 125/6 A 230V”. The product is the outdoor unit of an air-to-water heat pump with monobloc technology. The heat pump has a closed refrigerant circuit in which a refrigerant circulates. Through cyclic evaporation, compression, condensation and expansion, heat energy is absorbed from the environment and transferred to the building. In cooling mode, heat energy is extracted from the building and released to the environment.

In Figure 2 the structure of the product aroTHERM plus 12 kW is shown.

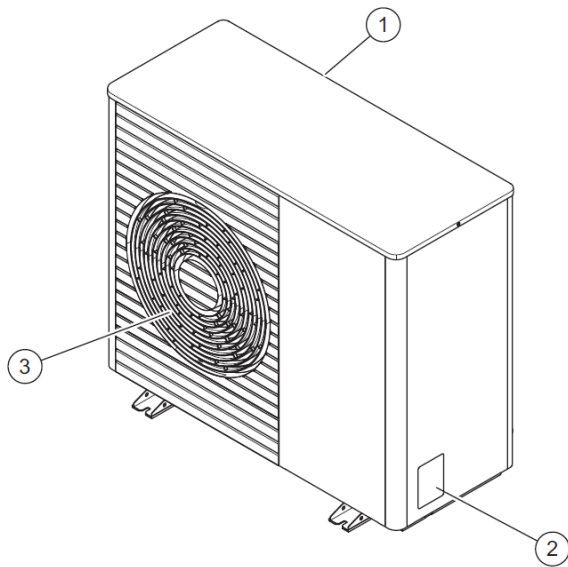

Figure 2: Structure of the product aroTHERM plus 12 kW

It contains the following components:

- (1) Air inlet grille
- (2) Nameplate
- (3) Air outlet grille

The Hydraulic Station is also known as „VWZ MEH 97/6“. In Figure 3 the structure of the product Hydraulic Station is shown.

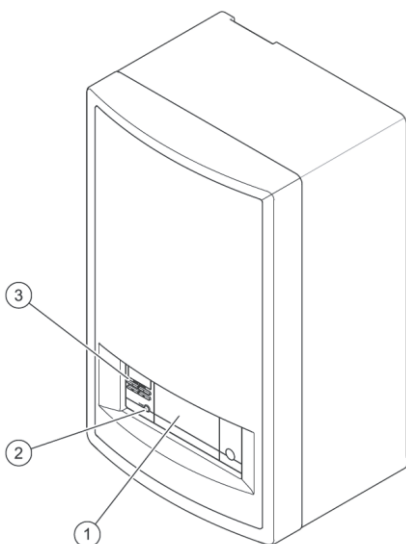

Figure 3: Structure of the product Hydraulic Station

It contains the following components:

- (1) Optional installation point for system controller
- (2) Suppression button
- (3) Operating elements

2.2 Raw materials

The raw materials for aroTHERM plus 12 kW (VWL 125/6 A S2 (mono 400 V)) are shown in Table 1.

Table 1: Mass percentages of the raw materials for aroTHERM plus 12 kW (VWL 125/6 A S2 (mono 400 V))

Raw material	Value	Unit
Steel	48	m%
Copper	22	m%
Aluminium	11	m%
PET	6	m%
ABS	3	m%
PP	3	m%
Bitumen	3	m%
Others	5	m%

The raw materials for Hydraulic Station are shown in Table 2.

Table 2: Mass percentages of the raw materials for Hydraulic Station

Raw material	Value	Unit
Steel	50	m%
Copper	21	m%
Brass	6	m%
ABS	6	m%
PVC	4	m%
PP	4	m%
PU	3	m%
EPS	2	m%
PCB	2	m%
Others	3	m%

2.3 Technical data

The technical data for aroTHERM plus 12 kW (VWL 125/6 A S2 (mono 400 V)) are listed in Table 3.

Table 3: Technical data of aroTHERM plus 12 kW (VWL 125/6 A S2 (mono 400 V))

Description	Value	Unit
Width	1100	mm
Height	1565	mm
Depth	450	mm

Weight with packaging	245,8	kg
Weight without packaging	217,3	kg
Voltage	400	V
Frequency	50	Hz
Pumped liquid	R290	-

The technical data for Hydraulic Station (VWL 125/ 6 A) are listed in Table 4.

Table 4: Technical data of Hydraulic Station

Description	Value	Unit
Width	440	mm
Height	720	mm
Depth	350	mm
Weight with packaging	26,5	kg
Weight without packaging	21,3	kg
Voltage	230/400	V
Frequency	50	Hz
Rated power	8,6	kW
Rated current	23,5/13,6	A

2.4 Substances of very high concern

No substance present in the product with a contribution of more than 0.1 % of the total weight is present on the "List of Potentially Hazardous Substances" (SVHC) that are candidates for authorisation under REACH legislation.

2.5 Manufacturing

The assembly, manufacturing and functional test of aroTHERM plus 12 kW takes place at the production and development sites in Remscheid (Germany), Nantes (France) and Belper (United Kingdom).

According to Vaillant there are the following assembly process steps for aroTHERM plus 12 kW:

- Pre-assembly of dedicated pre-assembly groups
- Transfer of Pre-assembled Modules to Final Assembly
- Final Assembly I
- Testing (High pressure test/ Helium Leakage Test)
- Final Assembly II
- Filling of appliances with Refrigerant
- Final Assembly III
- Testing (End of Line Test)
- Final Assembly IV
- Packaging
- Transport central storage

- Distribution

The assembly, manufacturing and functional test of Hydraulic Station takes place at the production and development site in Skalica (Slovakia).

According to Vaillant there are the following assembly process steps:

- Pre-assembly of dedicated pre-assembly groups
- Transfer of Pre-assembled Modules to Final Assembly
- Final Assembly I
- Testing (High pressure test/ End of Line)
- Final Assembly II
- Packaging
- Transport central storage
- Distribution

In Figure 4 the process flow chart for aroTHERM plus 12 kW & Hydraulic Station is shown.

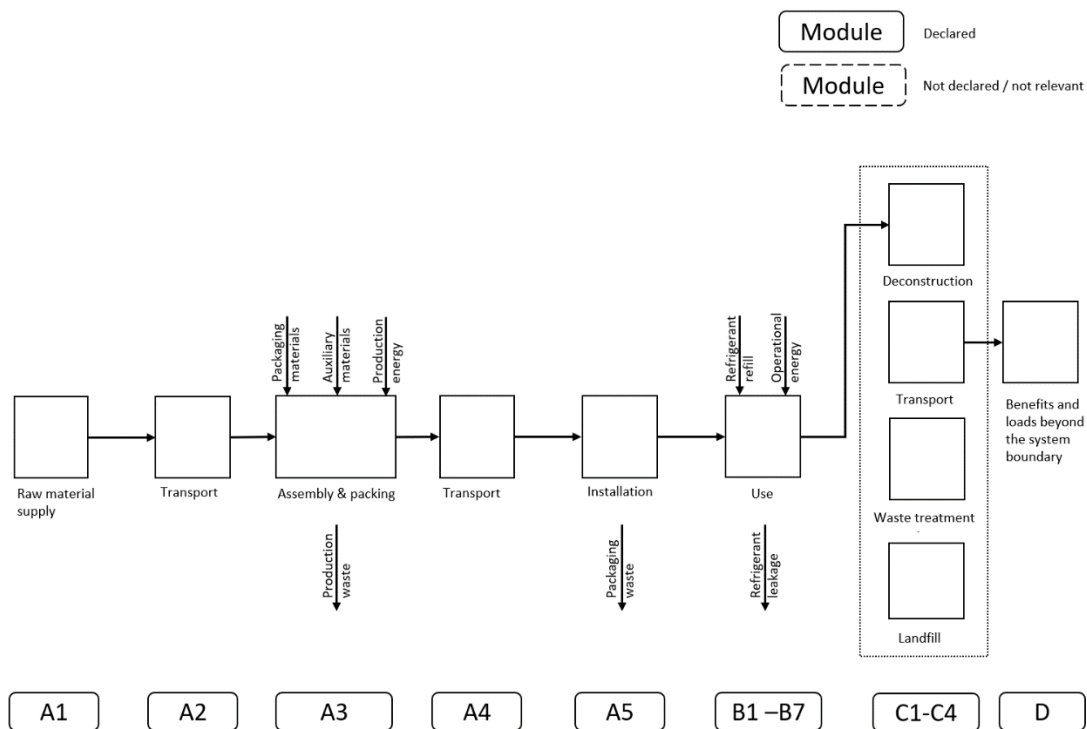

Figure 4: Process flow chart for aroTHERM plus 12 kW & Hydraulic Station

2.6 Reference service life

According to the PCR B, the reference service life (RSL) shall be in accordance with ISO 15686 if applicable. Since the RSL of heat pumps is not defined in ISO 15686, a reference service life (RSL) of 15 years is assumed in this EPD, which is confirmed by Vaillant as a valid realistic RSL.

2.7 Packaging

For the packaging of aroTHERM plus 12 kW EPS, paper, PE foil, Polyamide foil and wood are considered. For the packaging of Hydraulic Station carton, EPS, PE foil, PP and wood are considered.

2.8 Other information

Further information on the product can be found on the manufacturer's website (www.vaillant.com).

3. LCA: Calculation rules

3.1 Declared unit

According to the “PCR Guidance-Texts for Building-Related Products and Services – From the range of Environmental Product Declarations of Institute Construction and Environment e.V. (IBU) – Part B: Requirements on the EPD for HVAC Appliances” the declared unit is 1 piece of heat pump system. For the outdoor device, the “VWL 125/6 A S2 (mono 400 V)” variant results in a larger environmental impact compared to the other variant. Therefore, it is used as a worst-case in the calculation of the EPD.

Table 5: Declared unit

Description	Value	Unit
Declared unit	1	piece
Mass reference	272,3	kg/piece
Conversion factor to 1 kg	0,00367242	-
SCOP	4,9	-
Air flow (max. nominal volume)	4460	m ³ /h
E "heating"	3428,57	kWh/a
E "cooling"	1566,92	kWh/a

3.2 System boundary

This EPD was created in accordance with DIN EN 15804+A2. It monitors the production phase, construction phase, the use phase and the end-of-life phase as well as the benefits and loads beyond the system boundary. According to DIN EN 15804 this corresponds to the product phases A1-A5, B1-B7, C1-C4 and D. Therefore, the type of the EPD is “cradle to grave and module D”.

The modules include:

- A1: Extraction of the raw materials
- A2: Transport of the raw material to the production site by the suppliers
- A3: Auxiliary materials and energy for the different processing steps; Production waste; Packaging materials
- A4: Transport from the manufacturing site to the customers
- A5: According to the guide by Vaillant only human labour is needed for the construction/installation process and thus nothing is considered; Packaging waste
- B1: Emissions due to refrigerant leakage
- B2: Refill of refrigerant
- B3: No processes can be expected in module “repair”
- B4: No processes can be expected in module “replacement”
- B5: No processes can be expected in module “refurbishment”

- B6: Operational energy use is considered
- B7: No processes can be expected in module “operational water use”
- C1: According to the guide by Vaillant only human labour is needed for the de-construction/demolition process and thus nothing is considered
- C2: Transport for waste treatments based on NMD waste scenarios
- C3: Waste processing based on NMD waste scenarios
- C4: Disposal based on NMD waste scenarios
- D: Loads due to landfill, incineration and recycling; Benefits due to incineration and recycling

For the declared life phases, all inputs (raw materials, intermediate products, energy and auxiliary materials) as well as the waste produced were considered.

3.3 Estimates and assumptions

As the products consist of so many different components, Vaillant preferred to use a conservative approach for the transport of their suppliers (module A2). Therefore, a distance of 3500 km by truck is considered for all components from Europe and 1000 km by truck as well as 19000 km by transoceanic freight ship for all components from Asia.

The total operation time per year in heating mode t_{heating} was assumed to be 1400 hours while the total operation time per year in cooling mode was assumed to be 600 hours, according to the default active mode duration listed in PSR-0013.

For the end-of-life, waste scenarios from the Dutch Nationale Milieudatabase (NMD) waste scenarios were used.

The further assumptions are only included in the background report for data protection reasons.

3.4 Cut-off criteria

For process modules A1 to A3, all process-specific data was collected. All flows could be assigned potential environmental impacts through the Ecoinvent database 3.6. Production, supply, disposal, maintenance and end-of-life treatment of capital goods are included. In the used Ecoinvent database 3.6 infrastructure and capital goods are included. All flows that contribute more than 1% of the total mass, energy or environmental impact of the system have been included in the LCA. It can be assumed that the neglected processes contributed less than 5% to the impact categories considered. It is assumed that the contribution of capital goods to each individual environmental impact category of the module (A1-A3) is less than 5%.

As this EPD is not a declaration at company level, but a declaration at product level, capital goods for the production site are not taken into account, nor are packaging materials for the raw and auxiliary materials.

3.5 Period under review

All process-specific data were collected for the operating year 2023.

3.6 Comparability

In principle, a comparison or assessment of the environmental impact of different products is only possible if they have been produced in accordance with EN 15804. For the assessment of comparability, the following aspects in particular must be taken into account: PCR used, functional or declared unit, geographical reference, definition of the system boundary, declared modules, data selection

(primary or secondary data, background database, data quality), scenarios used for the use and disposal phases, and the life cycle inventory (data collection, calculation methods, allocations, validity period).

3.7 Background data

All the background data is taken from the Ecoinvent database version 3.6 (2019). The life cycle was modelled with the help of the EPD & LCA tool R<THiNK. Almost all consistent datasets contained in the Ecoinvent database version 3.6 (2019) are documented and can be viewed in the online documentation.

3.8 Data quality

Overall, the quality of the data can be considered as good. In the operating data survey, all relevant process-specific data could be collected. The data were provided by the manufacturer Vaillant.

Secondary data were taken from the Ecoinvent database version 3.6 (2019). The database is regularly checked and thus complies with the requirements of DIN EN ISO 14044 (background data not older than 10 years). The background data meets the requirements of EN 15804. The quantities of raw materials, consumables and supplies used as well as the energy consumption have been recorded and averaged over the entire year of operation.

The general rule has been complied that specific data from specific production processes or average data derived from specific processes must be given priority when calculating an EPD or Life Cycle Assessment. Data for processes that the manufacturer cannot influence or choose, were backed up with generic data.

The selection of the best fitting data sets is based on research and the help of experts. The transport distances for the waste treatments as well as the used environmental profiles for loads and benefits are based on the data from the NMD.

3.9 Allocation

Specific information about allocations within the background data is included in the documentation of the Ecoinvent datasets.

3.10 Data collection

The data collection was performed according to ISO 14044:2006, section 4.3.2. According to the target definition, all significant input and output flows that occur in connection with the products under consideration were identified and quantified. The inputs and outputs were attributed to the process in which they occur. For the process stages A1, A2 and A3, the input and output streams could be clearly assigned.

The results of the operational data collection can be seen in the following tables. In addition to the process-specific data, the tables also provide information on the respective background data used.

3.11 Calculation methods

For the life cycle assessment, the calculation methods described in the ISO 14044:2006, section 4.3.3 have been applied. The evaluation is based on the phases in the system boundaries and the processes contained therein.

3.12 Electricity mix and CO₂ certificates

The electricity mix was chosen according to the geographic reference space and time reference. As only the conventional electricity mix is used, no further energy sources were considered. The power mix composition is based on the Ecoinvent database version 3.6 (2019). No CO₂ certificates were counted.

4. LCA: Scenarios and additional technical information

The following scenarios are used in this EPD.

The EPD should be representative for Europe and thus Vaillant decided to consider their three main countries of use in Europe. Therefore, Germany, Italy and the United Kingdom are considered for the transport to the customers in module A4. Based on the percentages of the sales figures and the production locations, a distance of 921 km was calculated. The details can be found in the background report of this EPD.

Table 6: A4 – Transport from manufacturing sites to customers

	Value and Unit
Vehicle type used for transport	Lorry (Truck), unspecified (default) market group for (GLO)
Fuel type and consumption of vehicle	not available
Distance	921 km
Capacity utilisation (including empty returns)	50 % (loaded up and return empty)
Bulk density of transported products	inapplicable
Volume capacity utilisation factor	1

For input flows, there are no significant environment impacts as a result of materials or energy used in the construction stage (A5).

The following output flows leaving the system at module A5 are assumed.

Table 7: A5 – Assembly

Description	Value	Unit
Output materials as result of loss during construction	3	%
Output materials as result of waste processing of materials used for installation/assembly at the building site	0,000	kg
Output materials as result of waste processing of used packaging	32,403	kg

During the use stage carbon dioxide emissions to the air due to the annual refrigerant leakage of 2%, which is market compliant, is considered. For this the mass of the refrigerant R290 of 1,3 kg is multiplied by the leakage rate of 2% and the Global Warming Potential (GWP) value of 3 kg CO₂e/kg [Huber, 2022].

Table 8: B1 – Use

Description	Cycle (yr)	Number of cycles	Amount per cycle	Total Amount	Unit
Refrigerant leakage	1	15	78000	1170000	mg

Also, the annual refill of refrigerant is considered by multiplying the R290 mass of 1,3 kg with 2%.

Table 9: B2 – Maintenance

Description	Service cycle (yr)	Number of cycles (n)	Amount per cycle	Total Amount	Unit
Refrigerant refill	1	14	0,026	0,364	kg

The total energy consumed by the heat pump to operate is calculated as the combination of energy absorbed to exchange heat in heating and cooling mode along product RSL according to the PCR B. The annual operation energy use is 4995,49 kWh and the total operation energy use along RSL is 74932,38 kWh.

Table 10: B6 – Operational energy use

	Value	Unit
$P_{\text{heat, design}}$	12	kW
SCOP	4,9	-
T_{heating}	1400	hours/a
E_{heating}	3428,57	kWh/a
$P_{\text{cool, design}}$	12	kW
SEER	4,595	-
T_{cooling}	600	hours/a
E_{cooling}	1566,92	kWh/a
E_{use}	74932,38	kWh

As already described in section 3.3, the following waste scenarios are from the Dutch Nationale Milieudatabase (NMD).

Table 11: C2 - Transport End-of-Life

Waste treatment	Transport profile	Transport distance [km]
Landfill	Lorry (Truck), unspecified (default)	100
Incineration	Lorry (Truck), unspecified (default)	150
Recycling	Lorry (Truck), unspecified (default)	50

Table 12: Percentages of the waste treatments for the waste scenarios

Waste scenario	Landfill [%]	Incineration [%]	Recycling [%]	Reuse [%]
aluminium, cast alloy for buildings (i.a. profiles, sheets, pipes) (NMD ID 4)	3	3	94	0
bitumen (i.a. roofing material) (NMD ID 16)	5	90	5	0
copper (i.a. sheets, pipes) (NMD ID 41)	5	0	95	0
elastomeres (i.a. epdm, roofing, foils) (NMD ID 20)	10	85	5	0
EoL electronics - passive components	5	35	60	0
finishes (adhered to wood, plastic, metal) (NMD ID 2)	0	100	0	0
Galvanised steel (i.a. profiles, sheets) (NMD ID 75)	5	0	95	0
Metals, mixed (via residue (NMD ID 49)	5	5	90	0
no waste (empty scenario) (NMD ID 26)	0	0	0	0
plastics, reinforced (i.a. profiles, sheets, pipes) (NMD ID 46)	0	100	0	0
plastics, via residue (NMD ID 43)	20	80	0	0
polyolefines (i.a. pe,pp) (i.a. pipes, foils) (NMD ID 57)	10	85	5	0
PVC, pipes (NMD ID 64)	10	20	70	0
Sewage, to wastewater treatment, Average (EU)	0	0	100	0
Steel, light (NMD ID 73)	1	0	87	12
Waste scenario for chromium steel (based on NMD ID 50)	5	5	90	0
wood 'clean', via residue (NMD ID 35) (u=10%) corr. acc. EN16449	10	85	5	0
wood, contaminated (i.a. painted, preserved) (NMD ID 36) (u=10%, glue=2%) corr. acc. EN16449	5	95	0	0
Zinc / zinc coating galvanised steel (i.a. profiles, sheets, zinc coating) (NMD ID 75)	5	0	95	0

5. LCA: Results

The following tables show the results of the indicators of the impact assessment, the resource input as well as the waste materials and other output-flows. The results shown here refer to the declared unit.

Table 13: Overview of the considered information modules showing all phases of the building life cycle according to EN 15804 (X = module declared; MND = module not declared)

Production phase			Construction phase		Use phase							End-of-life phase				Benefits and loads beyond the system boundary
Raw material supply	Transport	Manufacturing	Transport	Construction/Installation process	Use	Maintenance	Repair	Replacements	Renewal	Operational energy use	Operational water use	De-construction demolition	Transport	Waste processing	Disposal	Reuse-, Recovery-, Recyclingpotential
A1	A2	A3	A4	A5	B1	B2	B3	B4	B5	B6	B7	C1	C2	C3	C4	D
X	X	X	X	X	X	X	X	X	X	X	X	X	X	X	X	X

Table 14: Results of the LCA – Environmental impact indicators: aroTHERM plus 12 kW & Hydraulic Station

Indicator (Impact Category)	Unit	A1	A2	A3	A4	A5	B1	B2	B3	B4	B5	B6	B7	C1	C2	C3	C4	D
AP	mol H+ eqv.	1,22E+01	7,44E-01	6,63E-01	1,88E-01	4,35E-01	0,00E+00	2,39E-03	0,00E+00	0,00E+00	0,00E+00	1,88E+02	0,00E+00	0,00E+00	1,16E-02	5,66E-02	9,60E-04	-3,20E+00
GWP-total	kg CO2 eqv.	9,07E+02	1,03E+02	2,50E+01	3,25E+01	9,25E+01	1,17E+00	4,07E-01	0,00E+00	0,00E+00	0,00E+00	3,32E+04	0,00E+00	0,00E+00	2,00E+00	9,27E+01	7,36E-01	-3,27E+02
GWP-b	kg CO2 eqv.	3,72E+00	4,34E-02	-4,84E+01	1,50E-02	4,81E+01	0,00E+00	4,09E-04	0,00E+00	0,00E+00	0,00E+00	9,66E+02	0,00E+00	0,00E+00	9,21E-04	6,38E-01	6,38E-02	1,50E+00
GWP-f	kg CO2 eqv.	9,01E+02	1,03E+02	7,33E+01	3,24E+01	4,43E+01	1,17E+00	4,06E-01	0,00E+00	0,00E+00	0,00E+00	3,22E+04	0,00E+00	0,00E+00	1,99E+00	9,20E+01	6,72E-01	-3,28E+02
GWP-luluc	kg CO2 eqv.	2,12E+00	3,95E-02	1,35E-01	1,19E-02	7,03E-02	0,00E+00	1,19E-04	0,00E+00	0,00E+00	0,00E+00	7,48E+01	0,00E+00	0,00E+00	7,31E-04	7,73E-03	6,14E-05	-2,60E-01
ETP-fw	CTUe	1,23E+05	1,36E+03	4,51E+03	4,36E+02	4,07E+03	0,00E+00	1,42E+01	0,00E+00	0,00E+00	0,00E+00	4,53E+05	0,00E+00	0,00E+00	2,68E+01	8,50E+02	4,34E+02	-4,15E+04
PM	disease incidence	6,86E-05	8,95E-06	6,20E-06	2,92E-06	2,81E-06	0,00E+00	2,29E-08	0,00E+00	0,00E+00	0,00E+00	4,92E-04	0,00E+00	0,00E+00	1,79E-07	5,69E-07	1,73E-08	-2,46E-05
EP-m	kg N eqv.	1,31E+00	2,43E-01	1,09E-01	6,63E-02	5,92E-02	0,00E+00	5,04E-04	0,00E+00	0,00E+00	0,00E+00	2,38E+01	0,00E+00	0,00E+00	4,08E-03	1,31E-02	5,97E-04	-4,09E-01
EP-fw	kg PO4 eqv.	1,36E-01	1,01E-03	6,68E-03	3,27E-04	4,39E-03	0,00E+00	3,11E-06	0,00E+00	0,00E+00	0,00E+00	3,43E+00	0,00E+00	0,00E+00	2,01E-05	3,52E-04	2,64E-06	-2,38E-02
EP-T	mol N eqv.	1,61E+01	2,68E+00	1,25E+00	7,31E-01	7,08E-01	0,00E+00	5,46E-03	0,00E+00	0,00E+00	0,00E+00	2,94E+02	0,00E+00	0,00E+00	4,49E-02	1,48E-01	3,39E-03	-5,43E+00
HTP-c	CTUh	4,99E-06	4,57E-08	1,68E-07	1,41E-08	2,64E-07	0,00E+00	1,46E-10	0,00E+00	0,00E+00	0,00E+00	1,17E-05	0,00E+00	0,00E+00	8,70E-10	3,99E-08	1,01E-10	-1,23E-06
HTP-nc	CTUh	1,30E-04	1,47E-06	5,19E-06	4,77E-07	4,24E-06	0,00E+00	7,00E-09	0,00E+00	0,00E+00	0,00E+00	3,99E-04	0,00E+00	0,00E+00	2,93E-08	4,96E-07	5,33E-09	-3,22E-05
IR	kBq U235 eqv.	4,06E+01	6,47E+00	3,89E+00	2,05E+00	1,68E+00	0,00E+00	1,49E-02	0,00E+00	0,00E+00	0,00E+00	5,72E+03	0,00E+00	0,00E+00	1,26E-01	3,85E-01	1,07E-02	-2,29E+00
SQP	Pt	5,06E+03	1,29E+03	7,83E+03	4,24E+02	4,55E+02	0,00E+00	3,31E+00	0,00E+00	0,00E+00	0,00E+00	1,62E+05	0,00E+00	0,00E+00	2,61E+01	6,35E+01	5,62E+00	-3,07E+03
ODP	kg CFC 11 eqv.	6,00E-05	2,26E-05	8,05E-06	7,16E-06	3,43E-06	0,00E+00	5,27E-08	0,00E+00	0,00E+00	0,00E+00	2,71E-03	0,00E+00	0,00E+00	4,40E-07	2,12E-06	3,19E-08	-1,69E-05
POCP	kg NMVOC eqv.	4,90E+00	7,54E-01	3,70E-01	2,09E-01	2,10E-01	0,00E+00	2,15E-03	0,00E+00	0,00E+00	0,00E+00	7,45E+01	0,00E+00	0,00E+00	1,28E-02	4,02E-02	1,12E-03	-1,81E+00
ADP-f	MJ	1,24E+04	1,54E+03	1,16E+03	4,89E+02	4,93E+02	0,00E+00	2,46E+01	0,00E+00	0,00E+00	0,00E+00	6,62E+05	0,00E+00	0,00E+00	3,01E+01	9,29E+01	2,55E+00	-3,31E+03
ADP-mm	kg Sb-eqv.	3,87E-01	2,51E-03	9,67E-03	8,22E-04	1,21E-02	0,00E+00	5,60E-06	0,00E+00	0,00E+00	0,00E+00	2,34E-01	0,00E+00	0,00E+00	5,05E-05	1,85E-04	1,07E-06	-5,39E-02
WDP	m³ world eqv.	3,98E+02	5,37E+00	2,46E+01	1,75E+00	1,36E+01	0,00E+00	1,54E-02	0,00E+00	0,00E+00	0,00E+00	7,41E+03	0,00E+00	0,00E+00	1,08E-01	3,18E+00	7,00E-02	-6,23E+01

AP = Acidification; GWP-total = Global warming potential – Total; GWP-b = Global warming potential – Biogenic; GWP-f = Global warming potential – Fossil; GWP-luluc = Global warming potential - Land use and land use change; ETP-fw = Ecotoxicity, freshwater; PM = Particulate Matter; EP-m = Eutrophication marine; EP-fw = Eutrophication, freshwater; EP-t = Eutrophication, terrestrial; HTP-c = Human toxicity, cancer; HTP-nc = Human toxicity, non-cancer; IR = Ionising radiation, human health; SQP = Land use; ODP = Ozone depletion; POCP = Photochemical ozone formation - human health; ADP-f = Resource use, fossils; ADP-mm = Resource use, minerals and metals; WDP = Water use

Table 15: Results of the LCA – Resource consumption, output streams & waste categories: aroTHERM plus 12 kW & Hydraulic Station

Parameter	Unit	A1	A2	A3	A4	A5	B1	B2	B3	B4	B5	B6	B7	C1	C2	C3	C4	D
PERE	MJ	1,69E+03	1,89E+01	6,93E+02	6,12E+00	7,36E+01	0,00E+00	6,71E-02	0,00E+00	0,00E+00	0,00E+00	1,25E+05	0,00E+00	0,00E+00	3,76E-01	9,55E+00	9,35E-02	-7,31E+02
PERM	MJ	6,31E-01	0,00E+00	4,13E+02	0,00E+00	1,24E+01	0,00E+00	0,00E+00	0,00E+00	0,00E+00	0,00E+00	0,00E+00	0,00E+00	0,00E+00	0,00E+00	0,00E+00	0,00E+00	0,00E+00
PERT	MJ	1,69E+03	1,89E+01	1,11E+03	6,12E+00	8,60E+01	0,00E+00	6,71E-02	0,00E+00	0,00E+00	0,00E+00	1,25E+05	0,00E+00	0,00E+00	3,76E-01	9,65E+00	9,40E-02	-7,31E+02
PENRE	MJ	1,21E+04	1,64E+03	1,09E+03	5,19E+02	4,87E+02	0,00E+00	2,72E+01	0,00E+00	0,00E+00	0,00E+00	6,94E+05	0,00E+00	0,00E+00	3,19E+01	9,80E+01	2,69E+00	-3,50E+03
PENRM	MJ	1,09E+03	0,00E+00	1,45E+02	0,00E+00	3,70E+01	0,00E+00	0,00E+00	0,00E+00	0,00E+00	0,00E+00	0,00E+00	0,00E+00	0,00E+00	0,00E+00	0,00E+00	0,00E+00	-2,82E+01
PENRT	MJ	1,32E+04	1,64E+03	1,24E+03	5,19E+02	5,25E+02	0,00E+00	2,72E+01	0,00E+00	0,00E+00	0,00E+00	6,94E+05	0,00E+00	0,00E+00	3,19E+01	9,91E+01	2,71E+00	-3,52E+03
SM	kg	5,61E+01	0,00E+00	2,10E+00	0,00E+00	1,75E+00	0,00E+00	0,00E+00	0,00E+00	0,00E+00	0,00E+00	0,00E+00	0,00E+00	0,00E+00	0,00E+00	0,00E+00	0,00E+00	3,18E-01
RSF	MJ	2,23E-04	0,00E+00	1,11E-05	0,00E+00	7,01E-06	0,00E+00	0,00E+00	0,00E+00	0,00E+00	0,00E+00	0,00E+00	0,00E+00	0,00E+00	0,00E+00	0,00E+00	0,00E+00	0,00E+00
NRSF	MJ	2,07E-04	0,00E+00	1,03E-05	0,00E+00	6,52E-06	0,00E+00	0,00E+00	0,00E+00	0,00E+00	0,00E+00	0,00E+00	0,00E+00	0,00E+00	0,00E+00	0,00E+00	0,00E+00	0,00E+00
FW	m ³	1,32E+01	1,83E-01	8,00E-01	5,96E-02	4,58E-01	0,00E+00	5,62E-04	0,00E+00	0,00E+00	0,00E+00	5,54E+02	0,00E+00	0,00E+00	3,66E-03	1,16E-01	2,73E-03	-1,62E+00
HWD	kg	1,75E-01	3,79E-03	4,57E-03	1,24E-03	9,85E-03	0,00E+00	3,49E-05	0,00E+00	0,00E+00	0,00E+00	4,41E-01	0,00E+00	0,00E+00	7,62E-05	1,42E-01	3,45E-06	1,48E-01
NHWD	kg	2,85E+02	9,36E+01	2,91E+01	3,10E+01	1,70E+01	0,00E+00	2,10E-01	0,00E+00	0,00E+00	0,00E+00	2,24E+03	0,00E+00	0,00E+00	1,91E+00	3,40E+00	9,85E+00	-8,15E+01
RWD	kg	3,65E-02	1,02E-02	4,34E-03	3,21E-03	1,74E-03	0,00E+00	2,25E-05	0,00E+00	0,00E+00	0,00E+00	4,70E+00	0,00E+00	0,00E+00	1,97E-04	3,86E-04	1,50E-05	-3,78E-03
CRU	kg	0,00E+00	0,00E+00	5,62E-01	0,00E+00	3,69E-01	0,00E+00	0,00E+00	0,00E+00	0,00E+00	0,00E+00	0,00E+00	0,00E+00	6. 0,00E+00	0,00E+00	1,12E+01	0,00E+00	0,00E+00
MFR	kg	0,00E+00	0,00E+00	7,52E+00	0,00E+00	5,62E+00	0,00E+00	0,00E+00	0,00E+00	0,00E+00	0,00E+00	0,00E+00	0,00E+00	0,00E+00	0,00E+00	1,71E+02	0,00E+00	0,00E+00
MER	kg	0,00E+00	0,00E+00	0,00E+00	0,00E+00	0,00E+00	0,00E+00	0,00E+00	0,00E+00	0,00E+00	0,00E+00	0,00E+00	0,00E+00	0,00E+00	0,00E+00	0,00E+00	0,00E+00	0,00E+00
EE-total	MJ	0,00E+00	0,00E+00	1,83E+01	0,00E+00	0,00E+00	0,00E+00	0,00E+00	0,00E+00	0,00E+00	0,00E+00	0,00E+00	0,00E+00	0,00E+00	0,00E+00	0,00E+00	0,00E+00	7,13E+02
EET	MJ	0,00E+00	0,00E+00	1,16E+01	0,00E+00	0,00E+00	0,00E+00	0,00E+00	0,00E+00	0,00E+00	0,00E+00	0,00E+00	0,00E+00	0,00E+00	0,00E+00	0,00E+00	0,00E+00	4,51E+02
EEE	MJ	0,00E+00	0,00E+00	6,72E+00	0,00E+00	0,00E+00	0,00E+00	0,00E+00	0,00E+00	0,00E+00	0,00E+00	0,00E+00	0,00E+00	0,00E+00	0,00E+00	0,00E+00	0,00E+00	2,62E+02

PERE = Renewable primary energy ex. raw materials; PERM = Renewable primary energy used as raw materials; PERT = Renewable primary energy total; PENRE = Non-renewable primary energy ex. raw materials; PENRM = Non-renewable primary energy used as raw materials; PENRT = Non-renewable primary energy total; SM = Use of secondary material; RSF = use of renewable secondary fuels; NRSF = Use of non-renewable secondary fuels; FW = Use of net fresh water; HWD = Hazardous waste disposed; NHWD = Non-hazardous waste disposed; RWD = Radioactive waste disposed; CRU = Components for re-use; MFR = Materials for recycling; MER = Materials for energy recovery; EE-total = Exported energy, total; EET = Exported energy thermic; EEE = Exported energy electric

7. LCA: Interpretation

For an easier understanding, the results are processed graphically, in order to recognize relationships and connections between the data more clearly.

The following figure shows the percentage of the product phases in the environmental impact categories.

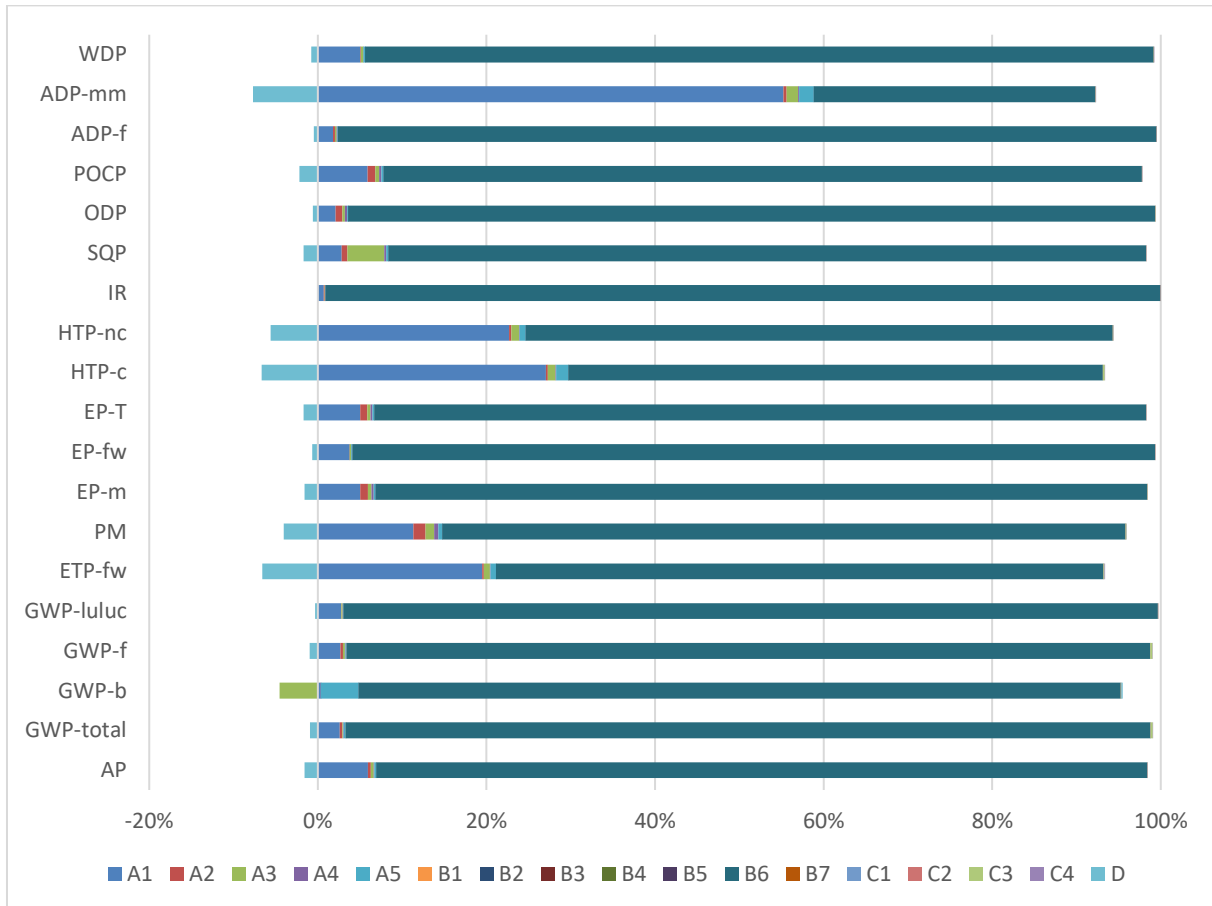

Figure 5: Percentage of the product phases in the environmental impact categories of aroTHERM plus 12 kW & Hydraulic Station

As can be seen in the graph, the operational energy use (module B6) dominates in almost all environmental impact categories, followed by the raw material supply (module A1). Furthermore, for the benefits or loads outside the system boundaries (module D) the benefits (negative values) dominate over the loads (positive values) in most of the environmental impact categories.

The limitations regarding the interpretation of the results are due to the assumptions made for the LCA, because it assesses the real world in a simplified model. It can be assumed that the results for the declared products are representative, because the quality of the data used can be classified as good overall. All relevant process-specific data could be collected in the operational data collection. Consistent data sets from the Ecoinvent database were available for all inputs and outputs.

As the raw material supply (module A1) has a big impact on the results for all products, the used datasets from Ecoinvent 3.6 for the different materials are important. For all materials matching datasets were found, thus, a high data quality can be assumed.

8. References

DIN EN ISO 14040	DIN EN ISO 14040: 2009-11: Environmental management - Life cycle assessment - Principles and framework (ISO 14040:2006)
DIN EN ISO 14044	DIN EN ISO 14044: 2018-05: Environmental management - Life cycle assessment - Requirements and guidelines (ISO 14044:2006 + Amd 1:2017)
DIN EN ISO 15804	DIN EN ISO 15804:2014-07: Sustainability of construction works - Environmental product declarations - Core rules for the product category of construction.
Ecoinvent, 2019	Ecoinvent database version 3.6 (2019)
EN ISO 14025	EN ISO 14025:20010: Environmental labels and declarations - Type III environmental declarations - Principles and procedures (ISO 14025:2010)
Huber, 2022	Temperature Control; Blog powered by Huber Kältemaschinenbau AG; http://www.temperaturecontrol.blog/sustainable-environmentally-safe-and-future-proof-temperature-control
PCR A	General Product Category Rules for Construction Products from the EPD program of Kiwa-Ecobility Experts; Version 2.1
PCR B	PCR Guidance-Texts for Building-Related Products and Services – From the range of Environmental Product Declarations of Institute Construction and Environment e.V. (IBU) – Part B: Requirements on the EPD for HVAC Appliances
R<THiNK, 2023	R<THiNK: EPD & LCA tool by NIBE (2023)
PCR EPDIItaly019	EPDIItaly Core PCR - HVAC Home Appliances, GPI version 5.0 (2021) www.epditaly.it
CPC 43912	PCR 2021:02 'Air-conditioning machines product group classification: UN CPC 43912' version 1.0.
EU regulation 206/212	Implementing Directive 2009/125/EC of the European Parliament and of the Council with regard to ecodesign requirements for air conditioners and comfort fans.
EU regulation 811/2013	of the Commission dated 18 February 2013 supplementing Guideline 2010/30/EU of the European Parliament and Council with regard to energy marking of room heaters, combination heating appliances, integrated systems comprising room heaters, temperature controllers and solar equipment as well as integrated systems comprising combination heating appliances, temperature controllers and solar equipment.
EU regulation 1254/2014	of the Commission dated 11 July 2014 supplementing Directive 2010/30/EU of the European Parliament and of the Council with regard to energy labelling of residential ventilation units
IPCC, 2007	Climate Change 2007: Synthesis Report. Contribution of Working Groups I, II and III to the Fourth Assessment Report of the Intergovernmental Panel on Climate Change [Core Writing Team, Pachauri, R.K and Reisinger, A. (eds.)]. IPCC, Geneva, Switzerland, 104 pp.
ISO 817	ISO 817:2014-05: Refrigerants - Designation and safety classification, Beuth-Verlag, Berlin.



DIN EN 14825	DIN EN 14825:2019-07: Air conditioners, liquid chilling packages and heat pumps, with electrically driven compressors, for space heating and cooling - Testing and rating at part load conditions and calculation of seasonal performance; German version EN 14825:2018, Beuth-Verlag, Berlin.
DIN EN 13141	DIN EN 13141-11:2019-04: Ventilation for buildings - Performance testing of components/products for residential ventilation - Part 1: Externally and internally mounted air transfer devices; German version EN 13141-1:2019, Beuth-Verlag, Berlin.
PSR-0013 PEP ecopassport	PSR-0013-ed2.0-EN-2019-12-06: Specific rules for thermodynamic generators with electric compression for heating and/or cooling of premises and/or the production of domestic hot water. PCR part B, v. 1.2: Requirements on the EPD for Air conditioner; Heat generators; Volume flow controllers and volume flow limiters for ventilation systems.
ISO 15686	ISO 15686-1:2011-05: Buildings and constructed assets - Service life planning - Part 1: General principles and framework.



VAILLANT GROUP

	Publisher: Kiwa-Ecobility Experts Kiwa GmbH, Ecobility Experts Wattstraße 11-13 13355 Berlin Germany	Mail Web	DE.Ecobility.Experts@kiwa.com www.kiwa.com/de/en/themes/ecobility-experts/
	Programme operator: Kiwa-Ecobility Experts Kiwa GmbH, Ecobility Experts Wattstraße 11-13 13355 Berlin Germany	Mail Web	DE.Ecobility.Experts@kiwa.com www.kiwa.com/de/en/themes/ecobility-experts/
	LCA practitioner: Kiwa GmbH, Ecobility Experts Wattstraße 11-13 13355 Berlin Germany	Tel Mail Web	+49 30 46 77 61 52 DE.Nachhaltigkeit@kiwa.com www.kiwa.com
VAILLANT GROUP	Owner of the declaration: Vaillant GmbH Berghauser Straße 40 42859 Remscheid Germany	Tel Mail Web	+49 2191 57 67 920 service@heizungonline.de www.vaillant.de

Kiwa-Ecobility Experts is established member of the

