

Owner of the declaration: Vaillant GmbH

Publisher: Kiwa-Ecobility Experts

Programme operator: Kiwa-Ecobility Experts

Registration number: EPD-Kiwa-EE-275-EN

Issue date: 13.09.2023

Valid until: 13.09.2028



unitOWER plus

The unitOWER plus is also known as „VIH QW 190/6 E“. This product is an indoor unit and system controller should be used in combination with aroTHERM.

1. General information

Vaillant GmbH

Programme operator:

Kiwa-Ecobility Experts
Voltastr. 5
13355 Berlin
Germany

Registration number:

EPD-Kiwa-EE-275-EN

Product category rules:

PCR A: General Program Category Rules for Construction Products from the EPD programme of Kiwa-Ecobility Experts; Version 2.1

PCR B: Nationale Milieudatabase (NMD): Environmental Performance Assessment Method for Construction Works; Calculation method to determine environmental performance of construction works throughout their service life, based on EN 15804; Version 1.1 (March 2022)

Issue date:

13.09.2023

Valid until:

13.09.2028



Frank Huppertz
(Head of Kiwa-Ecobility Experts)



Prof. Dr. Frank Heimbecher
(Chairman of the Independent expert committee of Kiwa-Ecobility Experts)

uniTOWER plus

Owner of the declaration:

Vaillant GmbH
Berghauser Straße 40
42859 Remscheid
Germany

Declared product / declared unit:

1 product unit

Scope:

This Environmental Product Declaration (EPD) is based on the life cycle assessment (LCA) of uniTOWER plus (VIH QW 190/6 E) produced by Vaillant in Nantes, France. The used geographical area is Europe.

The owner of the declaration shall be liable for the underlying information and evidence. Kiwa-Ecobility Experts shall not be liable with respect to manufacturer information, life cycle assessment data and evidences.

Verification:

The European standard EN 15804+A2:2019 serves as the core PCR.

Independent verification of the declaration and data according to ISO 14025:2006.

internally

externally

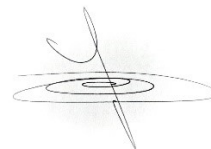

Anne Kees Jeeninga
(Third-party verifier by Advieslab)

2. Product

2.1 Product description

The uniTOWER plus is also known as „VIH QW 190/6 E“. This product is an indoor unit and system controller should be used in combination with aroTHERM. In Figure 1 the structure of the product uniTOWER plus is shown.

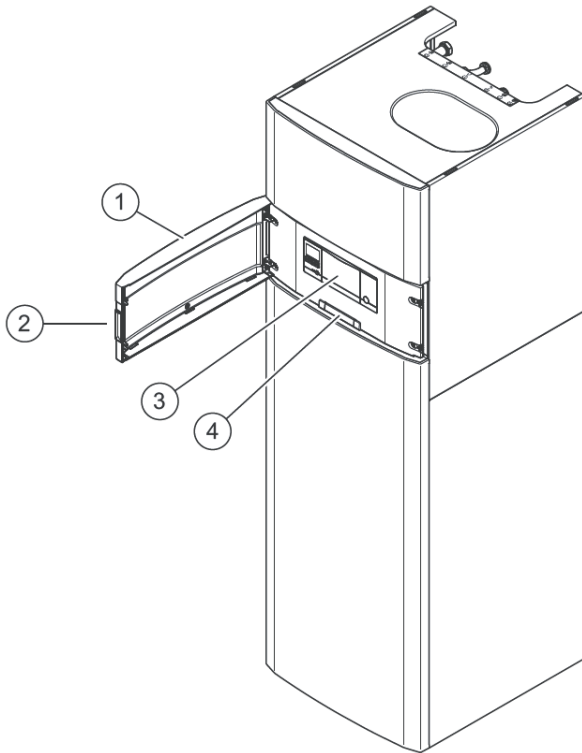

Figure 1: Structure of the product uniTOWER plus

It contains the following components:

- (1) Front cover
- (2) Recessed handle
- (3) Operating elements
- (4) Label with serial number on the rear

2.2 Raw materials

The raw materials for uniTOWER plus are shown in in Table 1.

Table 1: Mass percentages of the raw materials for uniTOWER plus

Raw material	Value	Unit
Steel	86%	m%
Copper	4%	m%
PU	3%	m%
Brass	2%	m%
Others	6%	m%

2.3 Technical data

The technical data for uniTOWER plus (VIH QW 190/6 E) are listed in Table 2.

Table 2: Technical data of uniTOWER plus

Description	Value	Unit
Width	595	mm
Height	1880	mm
Depth	693	mm
Weight with packaging	167,1	kg
Weight without packaging	147,4	kg
Voltage	230/400	V
Frequency	50	Hz
Rated power	8,6	kW
Rated current	23,5/13,6	A

2.4 Manufacturing

The assembly, manufacturing and functional test takes place at the production and development site in Nantes (France). In **Fehler! Verweisquelle konnte nicht gefunden werden.** the process flow chart for uniTOWER plus is shown.

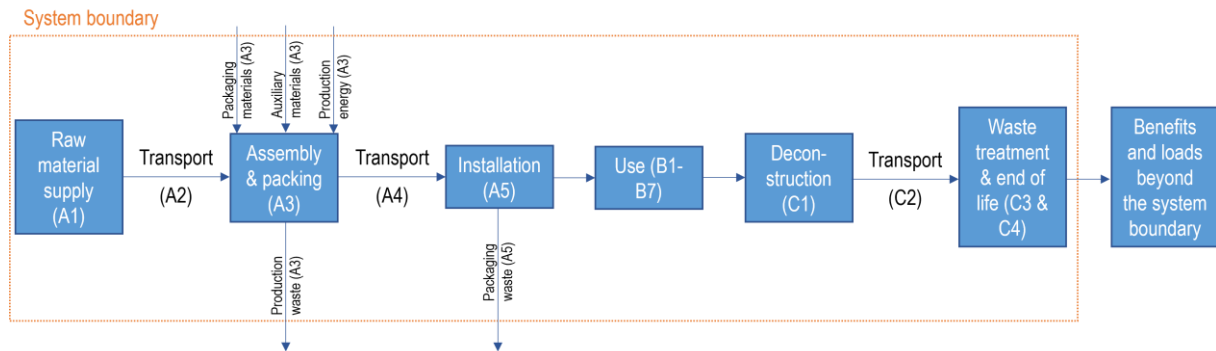

Figure 2: Process flow chart for uniTOWER plus

According to Vaillant there are the following assembly process steps:

- Pre-assembly of dedicated pre-assembly groups
- Transfer of Pre-assembled Modules to Final Assembly
- Final Assembly I
- Testing (High pressure test/ Helium Leakage Test)
- Final Assembly II
- Filling of appliances with Refrigerant
- Final Assembly III
- Testing (End of Line Test)
- Final Assembly IV
- Packaging
- Transport central storage
- Distribution

2.5 Reference service life

Based on the reference service life (RSL) of category 3 heat pumps of the NMD (Nationale Milieudatabase) and the experience of Vaillant, a RSL of 15 years is assumed.

2.6 Packaging

For the packaging of uniTOWER plus EPS, paper, PE foil, steel and wood are considered.

2.7 Other information

Further information on the product can be found on the manufacturer's website (www.vaillant.com).

3. LCA: Calculation rules

3.1 Declared unit

According to “Nationale Milieudatabase (NMD) – Bepalingsmethode Milieuprestatie Bouwwerken”, the declared unit is the product unit of the heat pump.

Table 3: Declared unit

Description	Value	Unit
Declared unit	1	Product unit

3.2 System boundary

This EPD was created in accordance with DIN EN 15804 and the Dutch Nationale Milieudatabase (NMD) Environmental Performance Assessment Method for Construction Works. It monitors the production phase, construction phase, the use phase and the end-of-life phase as well as the benefits and loads beyond the system boundary. According to DIN EN 15804 this corresponds to the product phases A1-A5, B1-B3, C1-C4 and D. Therefore, the type of the EPD is “cradle to grave”.

The modules include:

- A1: Extraction of the raw materials
- A2: Transport of the raw material to the production site by the suppliers
- A3: Auxiliary materials and energy for the different processing steps; Production waste; Packaging materials
- A4: Transport from the manufacturing site to the customers
- A5: According to the guide by Vaillant only human labour is needed for the construction/installation process and thus nothing is considered; Packaging waste
- B1: Nothing for use considered
- B2: Nothing for maintenance considered
- B3: Nothing for repair considered
- C1: According to the guide by Vaillant only human labour is needed for the de-construction/demolition process and thus nothing is considered
- C2: Transport for waste treatments based on NMD waste scenarios
- C3: Waste processing based on NMD waste scenarios
- C4: Disposal based on NMD waste scenarios
- D: Loads due to landfill, incineration and recycling; Benefits due to incineration and recycling

For the declared life phases, all inputs (raw materials, intermediate products, energy and auxiliary materials) as well as the waste produced were considered.

3.3 Estimates and assumptions

Since the products consist of so many different components, Vaillant preferred to use a conservative approach for the transport of their suppliers (module A2). Therefore, a distance of 3500 km by truck is considered for all components from Europe and 1000 km by truck as well as 19000 km by transoceanic freight ship for all components from Asia.

For the end-of-life, waste scenarios from the Dutch Nationale Milieudatabase (NMD) waste scenarios were used.

The further assumptions are only included in the background report for data protection reasons.

3.4 Cut-off criteria

For process modules A1 to A3, all process-specific data was collected. All flows could be assigned potential environmental impacts through the Ecoinvent database 3.6. Production, supply, disposal, maintenance and end-of-life treatment of capital goods are included. In the used Ecoinvent database 3.6 infrastructure and capital goods are included. All flows that contribute more than 1% of the total mass, energy or environmental impact of the system have been included in the LCA. It can be assumed that the neglected processes contributed less than 5% to the impact categories considered. It is assumed that the contribution of capital goods to each individual environmental impact category of the module (A1-A3) is less than 5%.

Since this EPD is not a declaration at company level, but a declaration at product level, capital goods for the production site are not taken into account, nor are packaging materials for the raw and auxiliary materials.

3.5 Period under review

All process-specific data were collected for the operating year 2021.

3.6 Comparability

In principle, a comparison or assessment of the environmental impact of different products is only possible if they have been produced in accordance with EN 15804. For the assessment of comparability, the following aspects in particular must be taken into account: PCR used, functional or declared unit, geographical reference, definition of the system boundary, declared modules, data selection (primary or secondary data, background database, data quality), scenarios used for the use and disposal phases, and the life cycle inventory (data collection, calculation methods, allocations, validity period).

3.7 Background data

All the background data is taken from the Ecoinvent database version 3.6 (2019). The life cycle was modelled with the help of the EPD & LCA tool R<THiNK. Almost all consistent datasets contained in the Ecoinvent database version 3.6 (2019) are documented and can be viewed in the online documentation.

3.8 Data quality

Overall, the quality of the data can be considered as good. In the operating data survey, all relevant process-specific data could be collected. The data were provided by the manufacturer Vaillant.

Secondary data were taken from the Ecoinvent database version 3.6 (2019). The database is regularly checked and thus complies with the requirements of DIN EN ISO 14044 (background data not older than 10 years). The background data meets the requirements of EN 15804. The quantities of raw materials, consumables and supplies used as well as the energy consumption have been recorded and averaged over the entire year of operation.

The general rule has been complied that specific data from specific production processes or average data derived from specific processes must be given priority when calculating an EPD or Life Cycle Assessment. Data for processes that the manufacturer cannot influence or choose, were backed up with generic data.

The selection of the best fitting data sets is based on research and the help of experts. The transport distances for the waste treatments as well as the used environmental profiles for loads and benefits are based on the data from the NMD.

3.9 Allocation

Specific information about allocations within the background data is included in the documentation of the Ecoinvent datasets.

3.10 Data collection

The data collection was performed according to ISO 14044:2006, section 4.3.2. According to the target definition, all significant input and output flows that occur in connection with the products under consideration were identified and quantified. The inputs and outputs were attributed to the process in which they occur. For the process stages A1, A2 and A3, the input and output streams could be clearly assigned.

The results of the operational data collection can be seen in the following tables. In addition to the process-specific data, the tables also provide information on the respective background data used.

3.11 Calculation methods

For the life cycle assessment, the calculation methods described in the ISO 14044:2006, section 4.3.3 have been applied. The evaluation is based on the phases in the system boundaries and the processes contained therein.

3.12 Electricity mix and CO₂ certificates

The electricity mix was chosen according to the geographic reference space and time reference. Since only the conventional electricity mix is used, no further energy sources were considered. The power mix composition is based on the Ecoinvent database version 3.6 (2019). No CO₂ certificates were counted.

4. LCA: Scenarios and additional technical information

The following scenarios are used in this EPD.

For the transport to the customers (module A4), the distance from the production location to Utrecht in the Netherlands should be used according to the NMD method. The distance by truck between Nantes in France, where the uniTOWER plus is manufactured, and Utrecht is 851 km.

Table 4: A4 – Transport from manufacturing site to customers

Description	Transport profile	Transport distance [km]
Distance between Nantes (France) and Utrecht (Netherlands)	Lorry (Truck), unspecified (default)	851

As already described in section 3.3, the following waste scenarios are from the Dutch Nationale Milieudatabase (NMD).

Table 5: Transport for waste treatments

Waste treatment	Transport profile	Transport distance [km]
Landfill	Lorry (Truck), unspecified (default)	100
Incineration	Lorry (Truck), unspecified (default)	150
Recycling	Lorry (Truck), unspecified (default)	50

Table 6: Percentages of the waste treatments for the waste scenarios

Waste scenario	Landfill [%]	Incineration [%]	Recycling [%]	Reuse [%]
aluminium, cast alloy for buildings (i.a. profiles, sheets, pipes) (NMD ID 4)	3	3	94	0
bitumen (i.a. roofing material) (NMD ID 16)	5	90	5	0
copper (i.a. sheets, pipes) (NMD ID 41)	5	0	95	0
elastomeres (i.a. epdm, roofing, foils) (NMD ID 20)	10	85	5	0
EoL electronics - passive components	5	35	60	0
finishes (adhered to wood, plastic, metal) (NMD ID 2)	0	100	0	0
Galvanised steel (i.a. profiles, sheets) (NMD ID 75)	5	0	95	0
Metals, mixed (via residue (NMD ID 49)	5	5	90	0
no waste (empty scenario) (NMD ID 26)	0	0	0	0
plastics, reinforced (i.a. profiles, sheets, pipes) (NMD ID 46)	0	100	0	0
plastics, via residue (NMD ID 43)	20	80	0	0
polyolefines (i.a. pe,pp) (i.a. pipes, foils) (NMD ID 57)	10	85	5	0
PVC, pipes (NMD ID 64)	10	20	70	0
Sewage, to wastewater treatment, Average (EU)	0	0	100	0
Steel, light (NMD ID 73)	1	0	87	12
Waste scenario for chromium steel (based on NMD ID 50)	5	5	90	0
wood 'clean', via residue (NMD ID 35) (u=10%) corr. acc. EN16449	10	85	5	0
wood, contaminated (i.a. painted, preserved) (NMD ID 36) (u=10%, glue=2%) corr. acc. EN16449	5	95	0	0
Zinc / zinc coating galvanised steel (i.a. profiles, sheets, zinc coating) (NMD ID 75)	5	0	95	0

5. LCA: Results

The following tables show the results of the indicators of the impact assessment, the resource input as well as the waste materials and other output-flows. The here shown results refer to the declared unit.

Table 7: Overview of the considered information modules showing all phases of the building life cycle according to NMD Environmental Performance Assessment Method for Construction Works (X = module declared; MND = module not declared)

Production phase			Construction phase		Use phase					End-of-life phase				Benefits and loads beyond the system boundary
Raw material supply	Transport	Manufacturing	Transport	Construction/Installation process	Use	Maintenance	Repair	Replacements	Renewal	De-construction demolition	Transport	Waste processing	Disposal	Reuse-, Recovery-, Recyclingpotential
A1	A2	A3	A4	A5	B1	B2	B3	B4	B5	C1	C2	C3	C4	D
X	X	X	X	X	X	X	X	X	X	X	X	X	X	X

Table 8: Results of the LCA – Environmental impact indicators (set 2): uniTOWER plus

Indicator (Impact Category)	Unit	A1	A2	A3	A4	A5	B1	B2	B3	B4	B5	C1	C2	C3	C4	D
AP	mol H+ eqv.	4,80E+00	3,92E-01	3,28E-01	1,08E-01	1,81E-01	0,00E+00	0,00E+00	0,00E+00	0,00E+00	0,00E+00	0,00E+00	6,12E-03	8,69E-03	2,88E-04	-1,05E+00
GWP-total	kg CO2 eqv.	5,39E+02	6,77E+01	2,24E+01	1,86E+01	5,41E+01	0,00E+00	0,00E+00	0,00E+00	0,00E+00	0,00E+00	0,00E+00	1,06E+00	2,66E+01	2,05E-01	-1,78E+02
GWP-b	kg CO2 eqv.	8,11E-01	3,12E-02	-2,47E+01	8,57E-03	2,45E+01	0,00E+00	0,00E+00	0,00E+00	0,00E+00	0,00E+00	0,00E+00	4,87E-04	2,80E-03	6,89E-04	8,31E-01
GWP-f	kg CO2 eqv.	5,38E+02	6,76E+01	4,70E+01	1,86E+01	2,96E+01	0,00E+00	0,00E+00	0,00E+00	0,00E+00	0,00E+00	0,00E+00	1,06E+00	2,66E+01	2,04E-01	-1,79E+02
GWP-luluc	kg CO2 eqv.	4,98E-01	2,48E-02	6,42E-02	6,80E-03	1,86E-02	0,00E+00	0,00E+00	0,00E+00	0,00E+00	0,00E+00	0,00E+00	3,87E-04	1,35E-03	1,30E-05	2,96E-02
ETP-fw	CTUe	4,34E+04	9,09E+02	1,97E+03	2,50E+02	1,53E+03	0,00E+00	0,00E+00	0,00E+00	0,00E+00	0,00E+00	0,00E+00	1,42E+01	2,05E+02	1,19E+01	-1,11E+04
PM	disease incidence	4,14E-05	6,08E-06	3,90E-06	1,67E-06	1,71E-06	0,00E+00	0,00E+00	0,00E+00	0,00E+00	0,00E+00	0,00E+00	9,50E-08	6,89E-08	5,58E-09	-1,20E-05
EP-m	kg N eqv.	6,37E-01	1,38E-01	6,34E-02	3,79E-02	3,05E-02	0,00E+00	0,00E+00	0,00E+00	0,00E+00	0,00E+00	0,00E+00	2,16E-03	2,52E-03	1,82E-04	-1,66E-01
EP-fw	kg PO4 eqv.	5,32E-02	6,82E-04	2,89E-03	1,87E-04	1,75E-03	0,00E+00	0,00E+00	0,00E+00	0,00E+00	0,00E+00	0,00E+00	1,07E-05	5,21E-05	5,15E-07	-8,41E-03
EP-T	mol N eqv.	7,64E+00	1,52E+00	7,21E-01	4,18E-01	3,57E-01	0,00E+00	0,00E+00	0,00E+00	0,00E+00	0,00E+00	0,00E+00	2,38E-02	2,79E-02	1,10E-03	-2,06E+00
HTP-c	CTUh	3,73E-07	2,95E-08	-1,33E-08	8,09E-09	6,46E-08	0,00E+00	0,00E+00	0,00E+00	0,00E+00	0,00E+00	0,00E+00	4,61E-10	1,51E-08	2,74E-11	-7,26E-07
HTP-nc	CTUh	8,38E-06	9,95E-07	1,24E-06	2,73E-07	3,65E-07	0,00E+00	0,00E+00	0,00E+00	0,00E+00	0,00E+00	0,00E+00	1,55E-08	1,38E-07	1,64E-09	1,13E-05
IR	kBq U235 eqv.	1,69E+01	4,27E+00	2,65E+00	1,17E+00	8,04E-01	0,00E+00	0,00E+00	0,00E+00	0,00E+00	0,00E+00	0,00E+00	6,67E-02	5,47E-02	3,57E-03	3,33E-01
SQP	Pt	2,32E+03	8,84E+02	4,01E+03	2,43E+02	2,33E+02	0,00E+00	0,00E+00	0,00E+00	0,00E+00	0,00E+00	0,00E+00	1,38E+01	5,18E+00	1,92E+00	-1,53E+03
ODP	kg CFC 11 eqv.	3,16E-05	1,49E-05	4,90E-06	4,10E-06	2,04E-06	0,00E+00	0,00E+00	0,00E+00	0,00E+00	0,00E+00	0,00E+00	2,33E-07	4,78E-07	1,11E-08	-7,81E-06
POCP	kg NMVOC eqv.	2,72E+00	4,35E-01	2,27E-01	1,19E-01	1,18E-01	0,00E+00	0,00E+00	0,00E+00	0,00E+00	0,00E+00	0,00E+00	6,79E-03	7,31E-03	3,56E-04	-9,58E-01
ADP-f	MJ	6,48E+03	1,02E+03	8,32E+02	2,80E+02	2,75E+02	0,00E+00	0,00E+00	0,00E+00	0,00E+00	0,00E+00	0,00E+00	1,59E+01	1,35E+01	8,23E-01	-1,62E+03
ADP-mm	kg Sb-eqv.	1,47E-01	1,71E-03	7,11E-03	4,70E-04	4,73E-03	0,00E+00	0,00E+00	0,00E+00	0,00E+00	0,00E+00	0,00E+00	2,68E-05	2,33E-05	3,16E-07	-1,42E-02
WDP	m ³ world eqv.	1,77E+02	3,65E+00	1,82E+01	1,00E+00	6,55E+00	0,00E+00	0,00E+00	0,00E+00	0,00E+00	0,00E+00	0,00E+00	5,70E-02	7,49E-01	2,40E-02	-2,95E+01

AP = Acidification; GWP-total = Global warming potential – Total; GWP-b = Global warming potential – Biogenic; GWP-f = Global warming potential – Fossil; GWP-luluc = Global warming potential - Land use and land use change; ETP-fw = Ecotoxicity, freshwater; PM = Particulate Matter; EP-m = Eutrophication marine; EP-fw = Eutrophication, freshwater; EP-t = Eutrophication, terrestrial; HTP-c = Human toxicity, cancer; HTP-nc = Human toxicity, non-cancer; IR = Ionising radiation, human health; SQP = Land use; ODP = Ozone depletion; POCP = Photochemical ozone formation - human health; ADP-f = Resource use, fossils; ADP-mm = Resource use, minerals and metals; WDP = Water use

Table 9: Results of the LCA – Resource consumption, output streams & waste categories: uniTOWER plus

Parameter	Unit	A1	A2	A3	A4	A5	B1	B2	B3	B4	B5	C1	C2	C3	C4	D
PERE	MJ	2,96E+02	1,28E+01	3,46E+02	3,50E+00	2,07E+01	0,00E+00	0,00E+00	0,00E+00	0,00E+00	0,00E+00	0,00E+00	1,99E-01	1,27E+00	2,47E-02	-3,24E+02
PERM	MJ	0,00E+00	0,00E+00	2,10E+02	0,00E+00	6,30E+00	0,00E+00	0,00E+00	0,00E+00	0,00E+00	0,00E+00	0,00E+00	0,00E+00	0,00E+00	0,00E+00	0,00E+00
PERT	MJ	6,51E+02	1,28E+01	5,74E+02	3,50E+00	3,82E+01	0,00E+00	0,00E+00	0,00E+00	0,00E+00	0,00E+00	0,00E+00	1,99E-01	1,36E+00	2,51E-02	-3,24E+02
PENRE	MJ	3,43E+03	1,08E+03	5,93E+02	2,97E+02	1,79E+02	0,00E+00	0,00E+00	0,00E+00	0,00E+00	0,00E+00	0,00E+00	1,69E+01	1,33E+01	8,49E-01	-1,71E+03
PENRM	MJ	3,27E+02	0,00E+00	1,35E+02	0,00E+00	1,39E+01	0,00E+00	0,00E+00	0,00E+00	0,00E+00	0,00E+00	0,00E+00	0,00E+00	0,00E+00	0,00E+00	-3,21E+00
PENRT	MJ	6,90E+03	1,08E+03	8,85E+02	2,97E+02	2,92E+02	0,00E+00	0,00E+00	0,00E+00	0,00E+00	0,00E+00	0,00E+00	1,69E+01	1,44E+01	8,74E-01	-1,72E+03
SM	kg	0,00E+00	0,00E+00	8,80E-03	0,00E+00	0,00E+00	0,00E+00	0,00E+00	0,00E+00	0,00E+00	0,00E+00	0,00E+00	0,00E+00	0,00E+00	0,00E+00	1,82E-01
RSF	MJ	0,00E+00	0,00E+00	0,00E+00	0,00E+00	0,00E+00	0,00E+00	0,00E+00	0,00E+00	0,00E+00	0,00E+00	0,00E+00	0,00E+00	0,00E+00	0,00E+00	0,00E+00
NRSF	MJ	0,00E+00	0,00E+00	0,00E+00	0,00E+00	0,00E+00	0,00E+00	0,00E+00	0,00E+00	0,00E+00	0,00E+00	0,00E+00	0,00E+00	0,00E+00	0,00E+00	0,00E+00
FW	m ³	5,21E+00	1,24E-01	4,97E-01	3,41E-02	1,97E-01	0,00E+00	0,00E+00	0,00E+00	0,00E+00	0,00E+00	0,00E+00	1,94E-03	2,50E-02	9,21E-04	-6,53E-01
HWD	kg	3,94E-02	2,58E-03	2,13E-03	7,09E-04	1,49E-03	0,00E+00	0,00E+00	0,00E+00	0,00E+00	0,00E+00	0,00E+00	4,04E-05	3,06E-03	1,16E-06	-1,32E-02
NHWD	kg	1,66E+02	6,47E+01	1,83E+01	1,78E+01	1,03E+01	0,00E+00	0,00E+00	0,00E+00	0,00E+00	0,00E+00	0,00E+00	1,01E+00	4,77E-01	3,75E+00	-5,54E+01
RWD	kg	1,49E-02	6,70E-03	3,13E-03	1,84E-03	8,67E-04	0,00E+00	0,00E+00	0,00E+00	0,00E+00	0,00E+00	0,00E+00	1,05E-04	4,83E-05	5,17E-06	-8,61E-04
CRU	kg	0,00E+00	0,00E+00	6,30E-01	0,00E+00	3,97E-01	0,00E+00	0,00E+00	0,00E+00	0,00E+00	0,00E+00	0,00E+00	0,00E+00	1,26E+01	0,00E+00	0,00E+00
MFR	kg	0,00E+00	0,00E+00	5,73E+00	0,00E+00	3,79E+00	0,00E+00	0,00E+00	0,00E+00	0,00E+00	0,00E+00	0,00E+00	0,00E+00	1,15E+02	0,00E+00	0,00E+00
MER	kg	0,00E+00	0,00E+00	0,00E+00	0,00E+00	0,00E+00	0,00E+00	0,00E+00	0,00E+00	0,00E+00	0,00E+00	0,00E+00	0,00E+00	0,00E+00	0,00E+00	0,00E+00
EE-total	MJ	0,00E+00	0,00E+00	6,99E+00	0,00E+00	0,00E+00	0,00E+00	0,00E+00	0,00E+00	0,00E+00	0,00E+00	0,00E+00	0,00E+00	0,00E+00	0,00E+00	2,93E+02
EET	MJ	0,00E+00	0,00E+00	4,42E+00	0,00E+00	0,00E+00	0,00E+00	0,00E+00	0,00E+00	0,00E+00	0,00E+00	0,00E+00	0,00E+00	0,00E+00	0,00E+00	1,85E+02
EEE	MJ	0,00E+00	0,00E+00	2,57E+00	0,00E+00	0,00E+00	0,00E+00	0,00E+00	0,00E+00	0,00E+00	0,00E+00	0,00E+00	0,00E+00	0,00E+00	0,00E+00	1,07E+02

PERE = Renewable primary energy ex. raw materials; PERM = Renewable primary energy used as raw materials; PERT = Renewable primary energy total; PENRE = Non-renewable primary energy ex. raw materials; PENRM = Non-renewable primary energy used as raw materials; PENRT = Non-renewable primary energy total; SM = Use of secondary material; RSF = use of renewable secondary fuels; NRSF = Use of non-renewable secondary fuels; FW = Use of net fresh water; HWD = Hazardous waste disposed; NHWD = Non-hazardous waste disposed; RWD = Radioactive waste disposed; CRU = Components for re-use; MFR = Materials for recycling; MER = Materials for energy recovery; EE-total = Exported energy, total; EET = Exported energy thermic; EEE = Exported energy electric

Table 10: Results of the LCA – Environmental impact indicators (set 1): uniTOWER plus

Indicator (Impact Category)	Unit	A1	A2	A3	A4	A5	B1	B2	B3	B4	B5	C1	C2	C3	C4	D
ADPE	kg antimony	1,47E-01	1,71E-03	7,11E-03	4,70E-04	4,73E-03	0,00E+00	0,00E+00	0,00E+00	0,00E+00	0,00E+00	0,00E+00	2,68E-05	2,33E-05	3,16E-07	-1,42E-02
ADPF	kg antimony	3,66E+00	4,93E-01	3,82E-01	1,35E-01	1,49E-01	0,00E+00	0,00E+00	0,00E+00	0,00E+00	0,00E+00	0,00E+00	7,70E-03	7,21E-03	3,90E-04	-1,13E+00
GWP	kg CO ₂	5,20E+02	6,71E+01	4,58E+01	1,84E+01	2,90E+01	0,00E+00	0,00E+00	0,00E+00	0,00E+00	0,00E+00	0,00E+00	1,05E+00	2,66E+01	1,77E-01	-1,70E+02
ODP	kg CFC 11	3,20E-05	1,19E-05	4,53E-06	3,26E-06	1,90E-06	0,00E+00	0,00E+00	0,00E+00	0,00E+00	0,00E+00	0,00E+00	1,86E-07	4,78E-07	8,89E-09	-8,40E-06
POCP	kg ethylene	6,54E-01	4,05E-02	3,83E-02	1,11E-02	2,39E-02	0,00E+00	0,00E+00	0,00E+00	0,00E+00	0,00E+00	0,00E+00	6,32E-04	5,91E-04	5,46E-05	-2,87E-01
AP	kg SO ₂	4,01E+00	2,95E-01	2,67E-01	8,09E-02	1,49E-01	0,00E+00	0,00E+00	0,00E+00	0,00E+00	0,00E+00	0,00E+00	4,60E-03	6,72E-03	2,17E-04	-8,59E-01
EP	kg (PO ₄) ³⁻	4,32E-01	5,79E-02	3,57E-02	1,59E-02	1,80E-02	0,00E+00	0,00E+00	0,00E+00	0,00E+00	0,00E+00	0,00E+00	9,05E-04	1,30E-03	8,30E-05	-9,33E-02
HTTP	kg 1.4 dichlorobenzene	1,77E+03	2,82E+01	6,21E+01	7,75E+00	5,83E+01	0,00E+00	0,00E+00	0,00E+00	0,00E+00	0,00E+00	0,00E+00	4,41E-01	5,60E+00	2,61E-02	-6,64E+02
FAETP	kg 1.4 dichlorobenzene	1,70E+01	8,24E-01	1,03E+00	2,26E-01	6,31E-01	0,00E+00	0,00E+00	0,00E+00	0,00E+00	0,00E+00	0,00E+00	1,29E-02	1,09E-01	1,08E-02	-1,36E+00
MAETP	kg 1.4 dichlorobenzene	5,49E+04	2,96E+03	3,16E+03	8,13E+02	1,99E+03	0,00E+00	0,00E+00	0,00E+00	0,00E+00	0,00E+00	0,00E+00	4,63E+01	3,13E+02	9,05E+00	-7,54E+03
TETP	kg 1.4 dichlorobenzene	4,18E+00	9,98E-02	4,96E-01	2,74E-02	1,40E-01	0,00E+00	0,00E+00	0,00E+00	0,00E+00	0,00E+00	0,00E+00	1,56E-03	5,76E-03	6,31E-05	4,74E+00

ADPE = Abiotic Depletion Potential for non-fossil resources; ADPF = Abiotic Depletion Potential for fossil resources; GWP = Global Warming Potential; ODP = Depletion potential of the stratospheric ozone layer; POCP = Formation potential of tropospheric ozone photochemical oxidants; AP = Acidification Potential of land and water; EP = Eutrophication Potential; HTP = Human Toxicity Potential; FAETP = Fresh water aquatic ecotoxicity potential; MAETP = Marine aquatic ecotoxicity potential; TETP = Terrestrial ecotoxicity potential

6. LCA: Interpretation

For an easier understanding, the results are processed graphically, in order to recognize relationships and connections between the data more clearly.

The following figure shows the percentage of the product phases in the environmental impact categories.

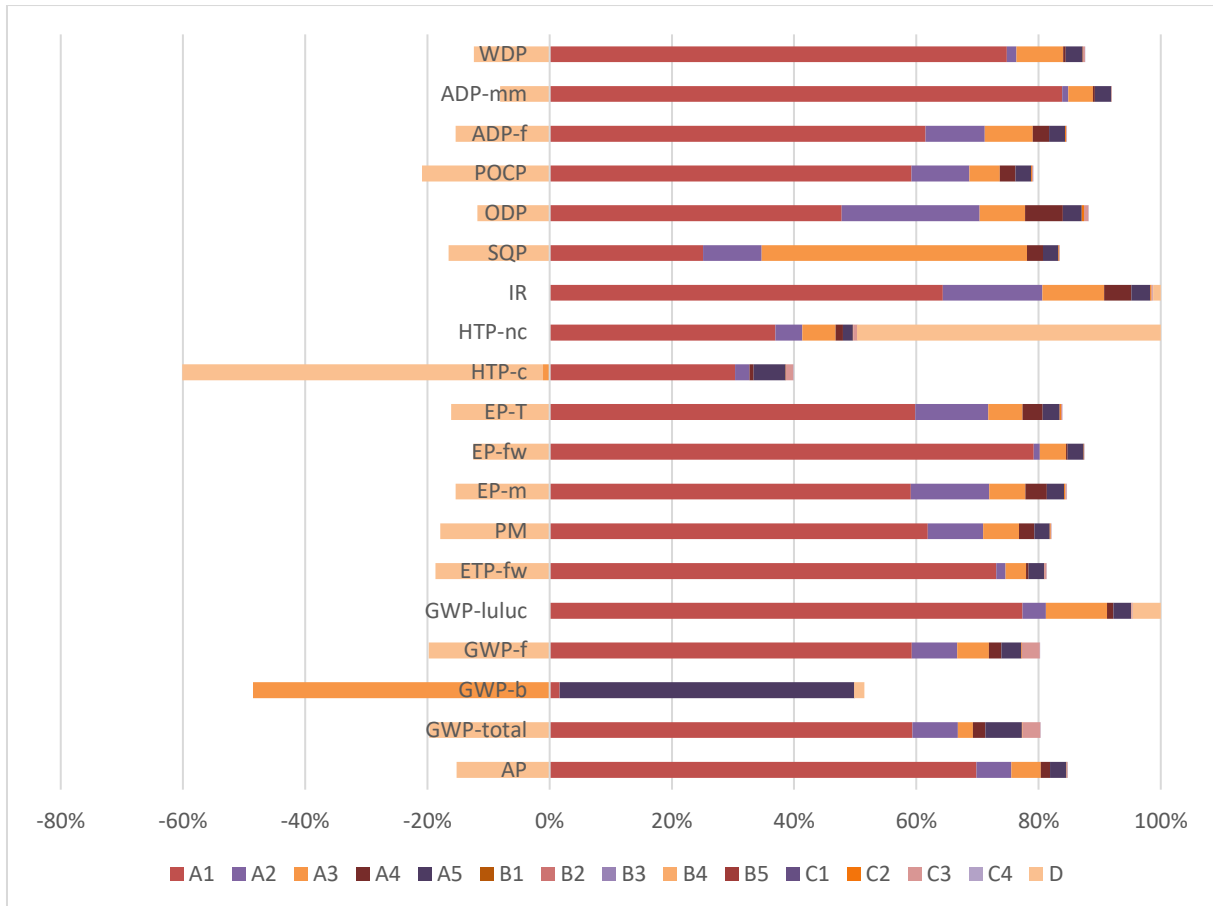

Figure 3: Percentage of the product phases in the environmental impact categories of uniTOWER plus

As can be seen in the graph, the raw material supply (module A1) dominates in almost all environmental impact categories, followed by the manufacturing (module A3). Furthermore, for the benefits or loads outside the system boundaries (module D) the benefits (negative values) dominate over the loads (positive values) in most of the environmental impact categories.

The limitations regarding the interpretation of the results are due to the assumptions made for the LCA, because it assesses the real world in a simplified model. It can be assumed that the results for the declared products are well representative, because the quality of the data used can be classified as good overall. All relevant process-specific data could be collected in the operational data collection. Consistent data sets from the Ecoinvent database were available for all inputs and outputs.

Since the raw material supply (module A1) dominates the results, the used datasets from Ecoinvent 3.6 for the different materials have a big impact. For all materials matching datasets could be found, so a high data quality can be assumed.

7. References

DIN EN ISO 14040	DIN EN ISO 14040: 2009-11: Environmental management - Life cycle assessment - Principles and framework (ISO 14040:2006)
DIN EN ISO 14044	DIN EN ISO 14044: 2018-05: Environmental management - Life cycle assessment - Requirements and guidelines (ISO 14044:2006 + Amd 1:2017)
DIN EN ISO 15804	DIN EN ISO 15804:2014-07: Sustainability of construction works - Environmental product declarations - Core rules for the product category of construction.
Ecoinvent, 2019	Ecoinvent database version 3.6 (2019)
EN ISO 14025	EN ISO 14025:2011-10: Environmental labels and declarations - Type III environmental declarations - Principles and procedures (ISO 14025:2006)
PCR A	General Program Category Rules for Construction Products from the EPD programme of Kiwa-Ecobility Experts; Version 2.0
PCR B	Nationale Milieudatabase (NMD): Environmental Performance Assessment Method for Construction Works; Calculation method to determine environmental performance of construction works throughout their service life, based on EN 15804; Version 1.1 (March 2022)
R<THiNK, 2023	R<THiNK: EPD & LCA tool by NIBE (2023)

	Publisher: Kiwa-Ecobility Experts Voltastr. 5 13355 Berlin Germany	Mail Web	DE.Ecobility.Experts@kiwa.com www.kiwa.com/de/en/themes/ecobility-experts/
	Programme operator: Kiwa-Ecobility Experts Voltastr. 5 13355 Berlin Germany	Mail Web	DE.Ecobility.Experts@kiwa.com www.kiwa.com/de/en/themes/ecobility-experts/
	LCA practitioner: Kiwa GmbH Voltastr. 5 13355 Berlin Germany	Tel Mail Web	+49 30 467761 43 DE.Nachhaltigkeit@kiwa.com www.kiwa.com
VAILLANT GROUP	Owner of the declaration: Vaillant GmbH Berghauser Straße 40 42859 Remscheid Germany	Tel Mail Web	+49 2191 57 67 920 service@heizungonline.de www.vaillant.de

Kiwa-Ecobility Experts is established member of the

