



EUROPEAN ASSESSMENT DOCUMENT

EAD 350142-00-1106

September 2017

FIRE PROTECTIVE PRODUCTS

FIRE PROTECTIVE BOARD, SLAB AND MAT PRODUCTS AND KITS

The reference title and language for this EAD is English. The applicable rules of copyright refer to the document elaborated in and published by EOTA.

This European Assessment Document (EAD) has been developed taking into account up-to-date technical and scientific knowledge at the time of issue and is published in accordance with the relevant provisions of Regulation (EU) No 305/2011 as a basis for the preparation and issuing of European Technical Assessments (ETA).

Contents

1	Scope of the EAD	5
1.1	Description of the construction product	5
1.2	Information on the intended use(s) of the construction product	6
1.2.1	Options of product assessment.....	6
1.2.2	Intended use(s) related to the elements to be protected	6
1.2.3	Intended uses related to climatic conditions	8
1.2.4	Working life/Durability.....	8
1.3	Specific terms used in this EAD	9
1.3.1	Boards	9
1.3.2	Slabs.....	9
1.3.3	Mats.....	9
1.3.4	Tiles	9
1.3.5	Composite boards (slabs or mats)	9
1.3.6	Finishing	9
1.3.7	Fixing products	9
1.3.7.1	Mechanical fastener.....	9
1.3.7.2	Adhesive	9
1.3.7.3	Fixing system	9
1.3.8	Insulation product	10
1.3.9	Jointing material (sealant)	10
1.3.10	Joint.....	10
1.3.11	Kit based on boards, slabs or mats (further referred to as "kit")	10
1.3.12	Supporting Framework	10
2	Essential characteristics and relevant assessment methods and criteria	11
2.1	Essential characteristics of the product	11
2.2	Methods and criteria for assessing the performance of the product in relation to essential characteristics of the product	14
2.2.1	Methods and criteria for assessing the performance of the kit	14
2.2.1.1	Reaction to fire.....	14
2.2.1.2	Resistance to fire.....	14
2.2.1.3	Durability.....	14
2.2.1.4	Content, emission and/or release of dangerous substances	15
2.2.1.5	Pull through resistance of mechanical fasteners	16
2.2.1.6	Shear load resistance of mechanical fastening systems	17
2.2.1.7	Resistance to functional failure from soft body impact load – 50 kg bag.....	18
2.2.1.8	Resistance to functional failure from hard body impact load – 0.5 kg steel ball	19
2.2.1.9	Resistance to eccentric load.....	19
2.2.1.10	Adhesion.....	20
2.2.1.11	Airborne sound insulation	21
2.2.1.12	Sound absorption	21
2.2.1.13	Impact sound insulation	21
2.2.1.14	Thermal insulation.....	21
2.2.1.15	Moisture transfer	22
2.2.2	Methods and criteria for assessing the performance of fire protective boards, slabs and mats.....	22
2.2.2.1	Reaction to fire.....	22
2.2.2.2	Resistance to fire.....	23
2.2.2.3	Durability.....	23
2.2.2.4	Extended durability assessment.....	24
2.2.2.5	Basic durability assessment.....	25
2.2.2.6	Demonstration of experience of 10 years favourable performance.....	25
2.2.2.7	Adhesion of finishings	26

2.2.2.8	Water permeability	26
2.2.2.9	Flexural strength	26
2.2.2.10	Dimensional stability	26
2.2.2.11	Thermal resistance	26
2.2.2.12	Water vapour transmission coefficient	26
2.2.2.13	Technical characterisation	26
2.2.3	Methods and criteria for assessing the performance of the mechanical fasteners	27
2.2.3.1	Reaction to fire	28
2.2.3.2	Durability	28
2.2.3.3	Pull-out resistance of mechanical fasteners	29
2.2.3.4	Technical characterisation	30
2.2.4	Methods and criteria for assessing the performance of the adhesives	30
2.2.4.1	Reaction to fire	31
2.2.4.2	Durability and serviceability requirements: Determination of freeze/thaw stability	31
2.2.4.3	Mechanical resistance and stability (of adhesives)	31
2.2.4.4	Technical characterisation	31
2.2.5	Methods and criteria for assessing the performance of the jointing material	32
2.2.5.1	Reaction to fire	32
2.2.5.2	Durability	32
2.2.5.3	Technical characterisation	33
2.2.6	Methods and criteria for assessing the performance of the insulation products	33
2.2.6.1	Reaction to fire	34
2.2.6.2	Durability	34
2.2.6.3	Water vapour transmission coefficient	34
2.2.6.4	Thermal insulation	35
2.2.6.5	Technical characterisation	35
2.2.7	Methods and criteria for assessing the performance of the profiles, framework and studs	36
2.2.7.1	Reaction to fire	36
2.2.7.2	Durability	36
2.2.7.3	Mechanical resistance and stability	37
2.2.7.4	Thermal insulation	38
2.2.7.5	Technical characterisation	38
3	Assessment and verification of constancy of performance	39
3.1	System(s) of assessment and verification of constancy of performance	39
3.1.1	For uses subject to reaction to fire regulations	39
3.1.2	For fire compartmentation and/or fire protection or fire performances	39
3.2	Tasks of the manufacturer	40
3.3	Tasks of the notified body	42
3.4	Special methods of control and testing used for the verification of constancy of performance	42
3.4.1	General	42
3.4.2	Product testing	43
3.4.3	Inspection and test status	43
4	Reference documents	44
	ANNEX A - List of annexes	48
	ANNEX B - EN 13823: Reaction to fire tests for building products - Building products excluding floorings exposed to the thermal attack by a single burning item - Mounting and fixing provisions	49
	ANNEX C - ASSESSMENT FOR COMPOSITE BOARDS	57
	ANNEX D - FREEZE/THAW CONDITIONING FOR USE CATEGORY Y	58

1 SCOPE OF THE EAD

1.1 Description of the construction product

This EAD specifies fire protective boards/panels, mats and slabs are products, which consist essentially of mineral fibres, vermiculite, calcium silicate, cement or gypsum or other appropriate materials, that are intended to be added to constructions for fire compartmentalisation or to load bearing elements or to building services to enhance and/or to preserve their fire performance.

This EAD is applicable to fire protective board, slab and mat products and kits. For the purpose of this EAD, the term "boards" will cover boards, slabs, tiles and mats, even when not explicitly mentioned, except for the clauses where distinction has been made. Tiles are considered to be boards or slabs of smaller size and are also covered by this EAD.

This EAD may be used to issue ETAs where the product under assessment is a board or a slab or a mat alone, as far as the ETA-applicant submits the product to a fire resistance assessment, using the appropriate 'characterisation' testing and assessment process. In such cases, the ETA-applicant will refer to other "generic" components required to assemble the product into an assembly, e.g. fixing products, supporting frame and joint material, technically characterised by reference to detailed specifications or to minimum performance characteristics, to which these generic products have to conform. The ETA then specifies the scope of the fire resistance performance for the assembly.

Fire protective composite board products and boards with finishings (see Annex C), also those which have a specific fire performance (e.g. reactive coatings), are covered by this EAD.

Board kits for forming self-supporting ducts or for cladding sheet metal ducts, for applications such as ventilation, smoke extraction or protection of services, are covered by this EAD. ETA-applicants placing such boards on the market may claim these performances, if they wish to do so. However, in these cases, compliance with EN 1507, EN 13403 and the relevant part(-s) of EN 12101 series needs to be assessed as well.

Fire protective suspended ceiling kits that are tested according to the provisions of EN 1364-2 or EN 13381-1 and classified according to EN 13501-2 and their components are covered by this EAD. For the assessment of fire protective ceiling kits and in addition to the provisions of this EAD the aspects covered by EN 13964:2004, not addressed in this EAD shall also be considered by the Notified Body, as far as relevant for the product or kit under consideration.

Excluded from the scope of this EAD are suspended ceilings, which are not especially intended for fire protective purposes.

Fire protective boards/panels, mats and slabs and kits thereof are not covered by a harmonised European standard (hEN).

Concerning product packaging, transport, storage, maintenance, replacement and repair it is the responsibility of the manufacturer to undertake the appropriate measures and to advise his clients on the transport, storage, maintenance, replacement and repair of the product as he considers necessary.

It is assumed that the product will be installed according to the manufacturer's instructions or (in absence of such instructions) according to the usual practice of the building professionals.

Relevant manufacturer's stipulations having influence on the performance of the product covered by this European Assessment Document shall be considered for the determination of the performance and detailed in the ETA.

1.2 Information on the intended use(s) of the construction product

1.2.1 Options of product assessment

Depending on the product to be assessed and taking into account the intended use related to the elements to be protected, the climatic conditions and the announce expected lifetime this EAD shall be used as follows:

- **For kits, based on boards, slabs or mats**, the complete EAD needs to be taken into account. The "kit" assessment is based on the assessment of kit related verifications (2.2.1) and the component related verifications as specified in clauses 2.2.2, 2.2.3, 2.2.4, 2.2.5, 2.2.6 and/or 2.2.7 (if and where relevant for the kit under consideration).
- **For boards, slabs or mats only** the clause of this EAD which needs to be taken into account is that which covers board, slab or mat related assessment methods (clause 2.2.2). Fire resistance is assessed, based on assembly testing, installed in accordance with ETA-applicant's specifications, taking into account minimum requirements for additional generic components, necessary to perform the test. In this case, and if the other provisions in clause 2.2 have been met, the product shall be considered as a fire protective board, slab or mat covered by this EAD.



1.2.2 Intended use(s) related to the elements to be protected

Fire protective products have been divided into product families related to the element they are intended to protect:

- Type 1: Fire protective products as a horizontal membrane protection,
- Type 2: Fire protective products as a vertical membrane protection,
- Type 3: Fire protective products to protect load-bearing concrete elements,
- Type 4: Fire protective products to protect load-bearing steel elements,
- Type 5: Fire protective products to protect load-bearing flat concrete profiled sheet composite elements
- Type 6: Fire protective products to protect load-bearing concrete filled hollow steel columns,
- Type 7: Fire protective products to protect load-bearing timber elements,
- Type 8: Fire protective products that contribute to the fire resistance of fire separating assemblies with no load bearing requirements
- Type 9: Fire protective products that contribute to the fire resistance of technical services assemblies in buildings
- Type 10: Further intended uses, related to fire compartmentalisation or protection of fire performance, not covered by types 1 to 9

Board, slab and mat products and kits for fire protective applications are intended to be used to protect construction elements in case of fire or to up-grade the resistance to fire of construction elements in buildings e.g. of floors, walls, columns, beams or other load-bearing elements. Board, slab and mat products and kits for fire protective applications may also be used as fire separating assemblies with no load bearing requirements. They may also contribute to the fire resistance of technical services assemblies in buildings.

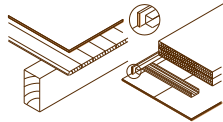
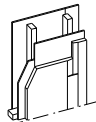
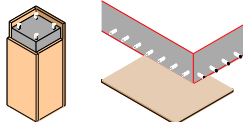
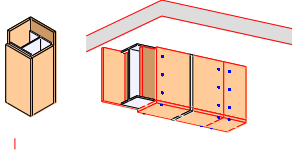
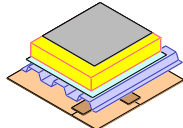
Table 1 Illustration of uses

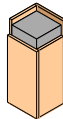
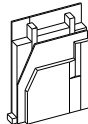
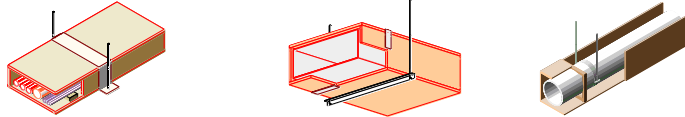
Use type	Protection of	Examples
Type 1	Horizontal membrane protection	
Type 2	Vertical membrane protection	
Type 3	Load-bearing concrete elements	
Type 4	Load-bearing steel elements	
Type 5	Load-bearing flat concrete profiled sheet composite elements	
Type 6	Fire Protective Products to protect load-bearing concrete filled hollow steel columns	
Type 7	Load-bearing timber elements	
Type 8	Fire separating assemblies with no load-bearing requirements	
Type 9	Fire Protective Products that contribute to the fire resistance of technical services assemblies in buildings	
Type 10	Uses not covered by types 1-9	All uses not covered above, except cavity barriers This type shall only be used in ETAs that already include this type.

In the framework of this EAD:

- The intended use type 8 covers intended uses where the fire protective board, slab and mat products and kits contribute to the fire resistance of fire separating elements (e.g. incorporation in walls, floors, doors, closures for conveyors, glazed screens, cavity barriers, fire resistant ceilings).

- The intended use type 9 covers intended uses where the fire protective board, slab and mat products and kits contribute to the fire resistance of other products that penetrate fire separating construction elements (e.g. incorporation in ventilation ducts, smoke extraction ducts, services ducts, chimneys).

1.2.3 Intended uses related to climatic conditions

For the purpose of this EAD, the fire protective board, slab and mat products and kits have been divided into product families related to their intended weather-exposure related use. In the framework of this EAD, the climatic conditions use categories are the following:

- Type X: Fire protective board, slab and mat products and kits intended for all uses (internal, semi-exposed and exposed)
- Type Y: Fire protective board, slab and mat products and kits intended for internal and semi-exposed use
- Type Z₁: Fire protective board, slab and mat products and kits intended for internal use, in high humidity environments¹.
- Type Z₂: Fire protective board, slab and mat products and kits intended for internal use only.

Note 1: Products that meet requirements for type X meet the requirements for all other types. Products that meet requirements for types Y and Z₁ also meet the requirements for type Z₂. However, products that meet the requirements for type Y do not necessarily meet the requirements for type Z₁.

Note 2: Requirements relevant for the assessment of the intended use related to climatic conditions are presented in clauses 2.2.1.3, 2.2.2.3, 2.2.2.4, 2.2.2.5, 2.2.2.6, 2.2.3.2, 2.2.4.2, 2.2.5.2, 2.2.6.2 and 2.2.7.2.

1.2.4 Working life/Durability

The assessment methods included or referred to in this EAD have been written based on the manufacturer's request to take into account a working life of the boards, slabs or mats products or kits for the intended use of 10 or 25 years when installed in the works (provided that the product or kit is subject to appropriate installation (see 1.1)). These provisions are based upon the current state of the art and the available knowledge and experience.

When assessing the product the intended use as foreseen by the manufacturer shall be taken into account. The real working life may be, in normal use conditions, considerably longer without major degradation affecting the basic requirements for works².

The indications given as to the working life of the construction product may not be interpreted as a guarantee neither given by the product manufacturer or his representative nor by EOTA when drafting this EAD nor by the Technical Assessment Body issuing an ETA based on this EAD, but are regarded only as a means for expressing the expected economically reasonable working life of the product.

¹ These uses apply for internal humidity class 5 in accordance with EN ISO 13788.

² The real working life of a product incorporated in a specific works depends on the environmental conditions to which that works is subject, as well as on the particular conditions of the design, execution, use and maintenance of that works. Therefore, it cannot be excluded that in certain cases the real working life of the product may also be shorter than referred to above.

1.3 Specific terms used in this EAD

1.3.1 Boards

Boards are rigid products of defined shape and cross section in which the thickness is uniform and substantially smaller than the other dimensions.

1.3.2 Slabs

Slabs are semi-rigid products of defined shape and cross section in which the thickness is uniform and substantially smaller than the other dimensions.

1.3.3 Mats

Mats are flexible fibrous (insulation) products supplied rolled or flat. The product may be faced e.g. for decorative purpose.

1.3.4 Tiles

Tiles are small square, rectangular or not rectangular boards or mats. A number of such products would normally be attached to a surface edge to edge, in order to provide fire protection.

1.3.5 Composite boards (slabs or mats)

Factory made boards, slabs or mats, composed of layers of different materials. In the framework of this EAD, board, slab or mat finishings are not considered to be a layer of different material.

1.3.6 Finishing

Factory applied continuous layer of a product in liquid, paste or powder form that, when applied to a surface, forms a film possessing protective, decorative and/or other specific properties.

In the framework of this EAD, a distinction is being made between decorative finishings, used to improve the aesthetical aspect of the boards (without changing the fire performance), and finishings which contribute to the performance of the board in case of fire.

1.3.7 Fixing products

1.3.7.1 Mechanical fastener

A mechanical fastener is a component intended to be used to fasten boards, slabs or mats to the substrate or supporting frame mechanically and is usually made of a (metal) screw, possibly with a plastic or metal washer, anchors, staples, clips, nails, bolts and nuts, rivets, etc.

1.3.7.2 Adhesive

An adhesive is a component intended to be used to join boards, slabs or mats to the substrate or supporting frame by surface bonding and is usually made of a non-metallic substance.

1.3.7.3 Fixing system

System composed of the mechanical fastener and all other components (e.g. plugs), if relevant, necessary to fasten boards, slabs or mats to the substrate or supporting frame.

1.3.8 Insulation product

An insulation product is a factory made component, usually supplied as boards or slabs, mats or rolls, incorporated behind boards or slabs or between them, intended to increase the thermal insulation of the assembled kit.

1.3.9 Jointing material (sealant)

A jointing material is a component intended to be used to fill and seal the joints between boards, slabs or mats or between boards, slabs or mats and other elements, in order for the complete fire protective board, slab or mat kit to fulfil some or all the requirements as specified in chapter 4. These materials may be:

- preformed materials (e.g. joint strips)
- unformed materials, which remain flexible (e.g. sealants) or become rigid (e.g. mortars) over time
- loose fill materials (e.g. mineral wool)

1.3.10 Joint

A joint is a construction formed by the adjacent parts of two or more products, components or building elements (e.g. between boards, slabs and mats or between boards, slabs or mats and other elements), when these are put together or fixed with, or without, the use of a jointing material. Open joints usually render the fire protective board, slab or mat kit unable to fulfil some or all the requirements as specified in chapter 4.

1.3.11 Kit based on boards, slabs or mats (further referred to as "kit")

Fire protective kits based on boards, slabs or mats, the kit comprises the fire protective boards, slabs or mats, and one or more of the following components: mechanical fasteners; adhesives; sealants; any other component, e.g. profiles, supporting framework and in-fill insulation.

1.3.12 Supporting Framework

Framework that consists of e.g. timber or metal profiles or sections, intended to support fire protective boards, slabs or mats.

2 ESSENTIAL CHARACTERISTICS AND RELEVANT ASSESSMENT METHODS AND CRITERIA

2.1 Essential characteristics of the product

The following tables show the performances of fire protective kits, board, slab and mat products and kit components is assessed in relation to the essential characteristics.

Table 2 Essential characteristics of the kit and methods and criteria for assessing the performance of the product in relation to those essential characteristics

No	Essential characteristic	Assessment method	Type of expression of product performance (level, class, description)
Basic Works Requirement 2: Safety in case of fire			
1	Reaction to fire	See clause 2.2.1.1	class
2	Resistance to fire	See clause 2.2.1.2	class
3	Durability and serviceability	See clause 2.2.1.3	Class
Basic Works Requirement 3: Hygiene, health and the environment			
4	Content, emission and/or release of dangerous substances	See clause 2.2.1.4	Description
Basic Works Requirement 4: Safety and accessibility in use			
5	Pull through resistance of mechanical fasteners	See clause 2.2.1.5	Level and description
6	Shear load resistance of mechanical fastening systems	See clause 2.2.1.6	Level
7	Resistance to soft body impact	See clause 2.2.1.7	Level
8	Resistance to hard body impact	See clause 2.2.1.8	Level
9	Resistance to eccentric load	See clause 2.2.1.9	Level
10	Adhesion	See clause 2.2.1.10	Level
Basic Works Requirement 5: Protection against noise			
11	Airborne sound insulation	See clause 2.2.1.11	Level
12	Sound absorption	See clause 2.2.1.12	Level
13	Impact sound insulation	See clause 2.2.1.13	Level
Basic Works Requirement 6: Energy economy and heat retention			
14	Thermal insulation	See clause 2.2.1.14	Level
15	Moisture transfer	See clause 2.2.1.15	Level

Table 3 Essential characteristics of the fire protective boards, slabs and mats and methods and criteria for assessing the performance of the product in relation to those essential characteristics

No	Essential characteristic	Assessment method	Type of expression of product performance (level, class, description)
Basic Works Requirement 2: Safety in case of fire			
16	Reaction to fire	See clause 2.2.2.1	class
17	Resistance to fire	See clause 2.2.2.2	class
18	Durability and serviceability	See clause 2.2.2.3 to 2.2.2.7	Class
Basic Works Requirement 3: Hygiene, health and the environment			
19	Water permeability	See clause 2.2.2.8	Description
Basic Works Requirement 4: Safety and accessibility in use			
20	Flexural strength	See clause 2.2.2.9	Level
21	Dimensional stability	See clause 2.2.2.10	Level
Basic Works Requirement 6: Energy economy and heat retention			
22	Thermal resistance	See clause 2.2.2.11	Level
23	Water vapour transmission coefficient	See clause 2.2.2.12	Level

Table 4 Essential characteristics of the mechanical fastener and methods and criteria for assessing the performance of the product in relation to those essential characteristics

No	Essential characteristic	Assessment method	Type of expression of product performance (level, class, description)
Basic Works Requirement 2: Safety in case of fire			
24	Reaction to fire	See clause 2.2.3.1	class
25	Durability and serviceability	See clause 2.2.3.2	Class
Basic Works Requirement 4: Safety and accessibility in use			
26	Pull-out resistance of mechanical fasteners	See clause 2.2.3.3	Level

Table 5 Essential characteristics of the adhesives and methods and criteria for assessing the performance of the product in relation to those essential characteristics

No	Essential characteristic	Assessment method	Type of expression of product performance (level, class, description)
Basic Works Requirement 2: Safety in case of fire			
27	Reaction to fire	See clause 2.2.4.1	class

No	Essential characteristic	Assessment method	Type of expression of product performance (level, class, description)
28	Durability and serviceability	See clause 2.2.4.2	Class
Basic Works Requirement 4: Safety and accessibility in use			
29	Mechanical resistance and stability	See clause 2.2.4.3	Level and description

Table 6 Essential characteristics of the jointing material and methods and criteria for assessing the performance of the product in relation to those essential characteristics

No	Essential characteristic	Assessment method	Type of expression of product performance (level, class, description)
Basic Works Requirement 2: Safety in case of fire			
30	Reaction to fire	See clause 2.2.5.1	class
31	Durability and serviceability	See clause 2.2.5.2	Class

Table 7 Essential characteristics of the Insulation products and methods and criteria for assessing the performance of the product in relation to those essential characteristics

No	Essential characteristic	Assessment method	Type of expression of product performance (level, class, description)
Basic Works Requirement 2: Safety in case of fire			
32	Reaction to fire	See clause 2.2.6.1	class
33	Durability and serviceability	See clause 2.2.6.2	Class
34	Water vapour transmission coefficient	See clause 2.2.6.3	Value
Basic Works Requirement 4: Safety and accessibility in use			
35	Thermal resistance	See clause 2.2.6.4	Value

Table 8 Essential characteristics of the profiles, framework and studs and methods and criteria for assessing the performance of the product in relation to those essential characteristics

No	Essential characteristic	Assessment method	Type of expression of product performance (level, class, description)
Basic Works Requirement 2: Safety in case of fire			
36	Reaction to fire	See clause 2.2.7.1	Class
37	Durability and serviceability	See clause 2.2.7.2	Class
Basic Works Requirement 4: Safety and accessibility in use			
38	Mechanical resistance and stability	See clause 2.2.7.3	Level
Basic Works Requirement 6: Energy economy and heat retention			
39	Thermal resistance	See clause 2.2.7.4	Value

2.2 Methods and criteria for assessing the performance of the product in relation to essential characteristics of the product

Characterisation of products to be assessed shall be done in accordance with available specifications, notably with the basic material properties which are relating to intended fire protective performance.

2.2.1 Methods and criteria for assessing the performance of the kit

2.2.1.1 Reaction to fire

Reaction to fire is being treated through the performance of the kits' components, see clauses 2.2.2.1, 2.2.3.1, 2.2.4.1, 2.2.5.1, 2.2.6.1 and 2.2.7.1.

The fire protective product/kit and/or components shall be tested according to the method(s) referred to in EN 13501-1 and relevant for the corresponding reaction to fire class. The product shall be classified according to the Commission Delegated Regulation (EU) No 2016/364.

2.2.1.2 Resistance to fire

The resistance to fire of a fire protective kit based on fire protective boards, slabs and mats shall be assessed according clause 2.2.2.2.

The part of the works or assembled system in which the fire protective product is intended to be incorporated, installed or applied shall be classified according to the appropriate part of EN 13501. The board kits shall be designated according to the element or elements they are intended to protect (see clause 1.2.2).

2.2.1.3 Durability

The assessment methods in clauses 2.2.2.3, 2.2.3.2, 2.2.4.2, 2.2.5.2, 2.2.6.2 and 2.2.7.2 shall be conducted on the boards, adhesives, fixing systems and/or jointing materials which are intended to be used as a part of the kit, unless similar tests have been performed on the basis of European product standards or EADs.

The board kits shall be categorised, according to their weather exposure (types X, Y, Z₁ and Z₂), based on the assessment of all components.

2.2.1.4 Content, emission and/or release of dangerous substances

The performance of kits with finishing and/or kits without finishing related to the emission and/or release and, where appropriate, the content of dangerous substances will be assessed on the basis of the information provided by the manufacturer³ after identifying the release scenarios (in accordance with EOTA TR 034) taking into account the intended use of the product and the Member States where the manufacturer intends his product to be made available on the market. Purely inorganic boards, slabs or mats alone and purely inorganic kits with fasteners and frames made of uncoated steel does not have to be tested.

The intended release scenarios for this product and intended use with respect to dangerous substances for this product are:

- IA1: Product with direct contact to indoor air.
- IA2: Product with indirect contact to indoor air (e.g. covered products) but possible impact on indoor air.
- SW 2: Product with indirect contact to soil, ground- and surface water.

2.2.1.4.1 SVOC and VOC

For the intended use covered by the release scenario IA1 and IA2 semi-volatile organic compounds (SVOC) and volatile organic compounds (VOC) are to be determined in accordance with EN 16516. The loading factor to be used for emission testing is determined in accordance with EN 16516.

Loading factors L in accordance with EN 16516, depending on the product type:

Loading factor [m ² /m ³]	Intended use
1,0	walls
0,4	floor, ceiling
0,05	small surfaces, e.g. door, window, heating system
0,007	very small surfaces, e.g. sealants

The preparation of the test specimen is performed by using all possible components of the kit (for the definition of the kit see clause 1.3.11) installed in accordance with the manufacturer's product installation instructions or (in absence of such instructions) the usual practice of installation.

Once the test specimen has been produced, as described above, it should immediately be placed in the emission test chamber or cell. This time is considered the starting time of the emission test.

The test results have to be reported for the relevant parameters (e.g. chamber size, temperature and relative humidity, air exchange rate, loading factor, size of test specimen, conditioning, production date, arrival date, test period, test result) after 3 and 28 days testing.

The relevant assessment results shall be expressed in [mg/m³] and stated in the ETA.

2.2.1.4.2 Leachable substances

³ The manufacturer may be asked to provide to the TAB the REACH related information which he must accompany the DoP with (cf. Article 6(5) of Regulation (EU) No 305/2011).

The manufacturer is not obliged:

- to provide the chemical constitution and composition of the product (or of constituents of the product) to the TAB, or
- to provide a written declaration to the TAB stating whether the product (or constituents of the product) contain(s) substances which are classified as dangerous according to Directive 67/548/EEC and Regulation (EC) No 1272/2008 and listed in the "Indicative list on dangerous substances" of the SGDS.

Any information provided by the manufacturer regarding the chemical composition of the products may not be distributed to EOTA or to TABs.

For the intended use covered by the release scenario S/W1 the performance of the bonding material concerning leachable substances shall be assessed. A leaching test with subsequent eluate analysis shall take place, each in duplicate. Leaching tests of the bonding material are conducted according to CEN/TS 16637-2. The leachant shall be pH-neutral demineralised water and the ratio of liquid volume to surface area must be $(80 \pm 10) \text{ l/m}^2$.

Cubes of the bonding material with dimensions of 100 mm x 100 mm x 100 mm shall be prepared.

In eluates of "6 hours" and "64 days", the following biological tests shall be conducted:

- Acute toxicity test with *Daphnia magna* Straus according to EN ISO 6341
- Toxicity test with algae according to ISO 15799
- Luminescent bacteria test according to EN ISO 11348-1, EN ISO 11348-2 or EN ISO 11348-3

For each biological test, EC20-values shall be determined for dilution ratios 1:2, 1:4, 1:6, 1:8 and 1:16.

If the parameter TOC is higher than 10 mg/l, the following biological tests shall be conducted with the eluates of "6 hours" and "64 days" eluates:

- Biological degradation according to OECD Test Guideline 301 part A, B or E.

Determined toxicity in biological tests shall be expressed as EC20-values for each dilution ratio. Maximum determined biological degradability shall be expressed as "...% within ...hours/days". The respective test methods for analysis shall be specified.

2.2.1.5 Pull through resistance of mechanical fasteners

2.2.1.5.1 Conditioning:

For all "Safety in use" assessment methods, the following conditioning shall take place.

The sample boards and mechanical fasteners are conditioned, at $(23 \pm 2) \text{ }^\circ\text{C}$ and $(50 \pm 5) \text{ \%RH}$, until constant mass, i.e. until two subsequent measurements, with a minimum interval of 24 h, differ less than 0,1 %.

2.2.1.5.2 Test conditions:

During all "Safety in use" assessment methods, the following laboratory conditions shall apply: $(20 \pm 10) \text{ }^\circ\text{C}$ and $(50 \pm 20) \text{ \%RH}$.

2.2.1.5.3 Pull through resistance testing

This test method shall be carried out for mechanically fixed systems only and establishes the pull-through resistance of a mechanical fastener through the penetration in the fire protective board.

The test is carried out on 5 sample boards, each measuring $(250 \times 250) \text{ mm}$ nominally.

The apparatus consists of:

- a dynamometer,
- a support (**Figure 1**)

Dimensions in mm

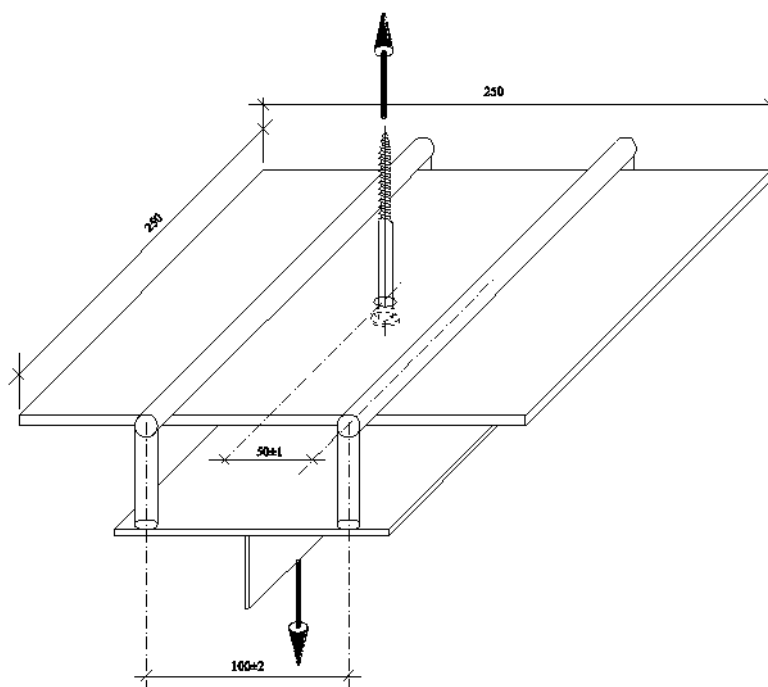

Figure 1: Principle of pull-through test assembly

The mechanical fasteners are installed in accordance with the manufacturer's specifications. For the purpose of this test, the mechanical fastener shall be applied in the centre of the samples.

The tensile force for pulling through the mechanical fastener shall be measured with a dynamometer. The tensioning speed is (20 ± 1) mm/min.

The maximum pull-through resistance of each test is expressed in N. The assessment results, the mode of failure and mean value are recorded in the test report.

2.2.1.5.4 Test after immersion in water

In case the board kit is intended to be used in climatic conditions type X or Type Y (see clause 1.2.3), the test as in clause 2.2.1.5.3 shall also be conducted after the board has been immersed completely during 1h at (20 ± 10) °C.

2.2.1.6 Shear load resistance of mechanical fastening systems

This test method shall be carried out for mechanically fastened systems only and establishes the shear load resistance of a mechanical fastening system, installed through the fire protective board into a wooden batten (**Figure 2**).

The test is carried out on 5 sample boards, each measuring 150 mm x 50 mm x d, nominally, where d is the thickness of the board. The apparatus consists of a dynamometer.

One mechanical fastener is installed in each sample at (50 ± 2) mm from the top and (25 ± 2) mm from the sides, in accordance with the manufacturer's specifications. The test rig shall prevent torque, i.e. prevent eccentric forces being applied resulting in an additional loading.

The shear failure load shall be measured with a dynamometer. The tensioning speed is $(0,5 \pm 0,1)$ mm/min. Only when the board is completely loose from the substrate, shall the test be terminated, and the result registered. The maximum shear (failure) load of each test is expressed in N. The test results, the mode of failure and mean value are recorded in the test report.

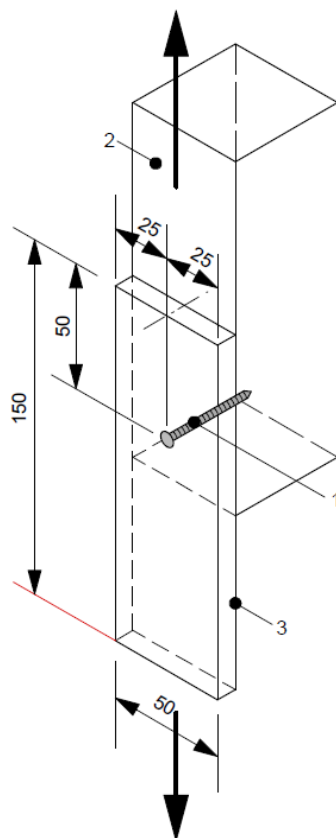
**Key**

- 1 **Mechanical fastener**
- 2 **Wooden batten (t x 50 x 150)**
- 3 **Board**

Dimensions in mm

t: thickness of the batten

Figure 2: Principle of shear load resistance test assembly

The ETA shall specify the mean value of five test results. The test result and the mode of failure may lead to restrictions on the use of the kit in the ETA.

2.2.1.7 Resistance to functional failure from soft body impact load – 50 kg bag

The need to evaluate the resistance to soft body impact is restricted to assemblies intended to be used in applications where soft body impact to the fire protective board assembly is likely to occur and for which impact resistance is claimed.

Test method as specified in EOTA TR001:2003, clause 1, with the following modifications:

The test rig is composed of a solid wall, in front of which one full size sample board (at least 1,00 m x 2,00 m) is fixed, on a supporting frame or profiles and with fixing system or adhesive as specified and installed in accordance with the manufacturer's specifications.

The height of the bag before the release shall depend on the claims made by the manufacturer. To prevent progressive damage from influencing the test results, the impact resistance test shall always be conducted on new assemblies.

After testing the sample shall be inspected for visible signs of damage (cracking, spalling or delamination from the substrate) and the dimensions of any detached pieces measured.

The test report shall show the impact resistance (energy in Nm) that the system resisted without damage. The test report shall record all visible damage sustained at higher impact levels.

Note 3: If the resistance to impact/movement for vertical elements is relevant, ISO 7892 may apply.

The ETA shall specify the soft body impact resistance that the board, installed in accordance with the manufacturer's specifications, resisted, in accordance with EOTA TR001:2003 and taking into account the recommendations presented in Annex A of EOTA TR001:2003.

2.2.1.8 Resistance to functional failure from hard body impact load – 0.5 kg steel ball

The need to evaluate the resistance to hard body impact is restricted to assemblies intended to be used in applications where hard body impact to the fire protective board assembly is likely to occur and for which impact resistance is claimed.

Test method as specified in EOTA TR001:2003, clause 2, with the following modifications:

The test rig is composed of a solid wall, in front of which one full size sample board (at least 1,00 m x 2,00 m) is fixed, on a supporting frame or profiles and with fixing system or adhesive as specified and installed in accordance with the manufacturer's specifications.

The height of the ball before the release shall depend on the claims made by the manufacturer.

After testing the sample shall be inspected for visible signs of damage (cracking, spalling or delamination from the substrate) and the dimensions of any detached pieces measured.

The test report shall show the impact resistance (energy in Nm) that the system resisted without visible damage. The test report shall record all visible damage sustained at higher impact levels.

The ETA shall specify the hard body impact resistance that the board, installed in accordance with the manufacturer's specifications, resisted, in accordance with EOTA TR001:2003 and taking into account the recommendations presented in Annex A of EOTA TR001:2003

2.2.1.9 Resistance to eccentric load

Usually, manufacturers will not claim resistance to functional failure from eccentric vertical load. However, if such claim is made, testing of fire protective board kits for support of an eccentric vertical downward load shall be performed as described in ISO/DIS 8413, with the following amendments and modifications:

The test rig is composed of a solid wall, in front of which one full size sample board (at least 1,00 m x 2,00 m) is fixed, on a supporting frame or profiles and with fixing system or adhesive as specified and installed in accordance with the manufacturer's specifications. The test needs to be repeated for each variation of fixing system and/or adhesive and for each fixing pattern.

At half height, two frames are attached to the board, at (500 ± 10) mm from each other, each with two mechanical fasteners, which are 150 mm apart. At a distance of (300 ± 10) mm from the surface of the board, a vertical load is attached in the centre of the connection between the two frames, during (24 ± 1) h (see **Figure 3**). The load may be specified by the manufacturer.

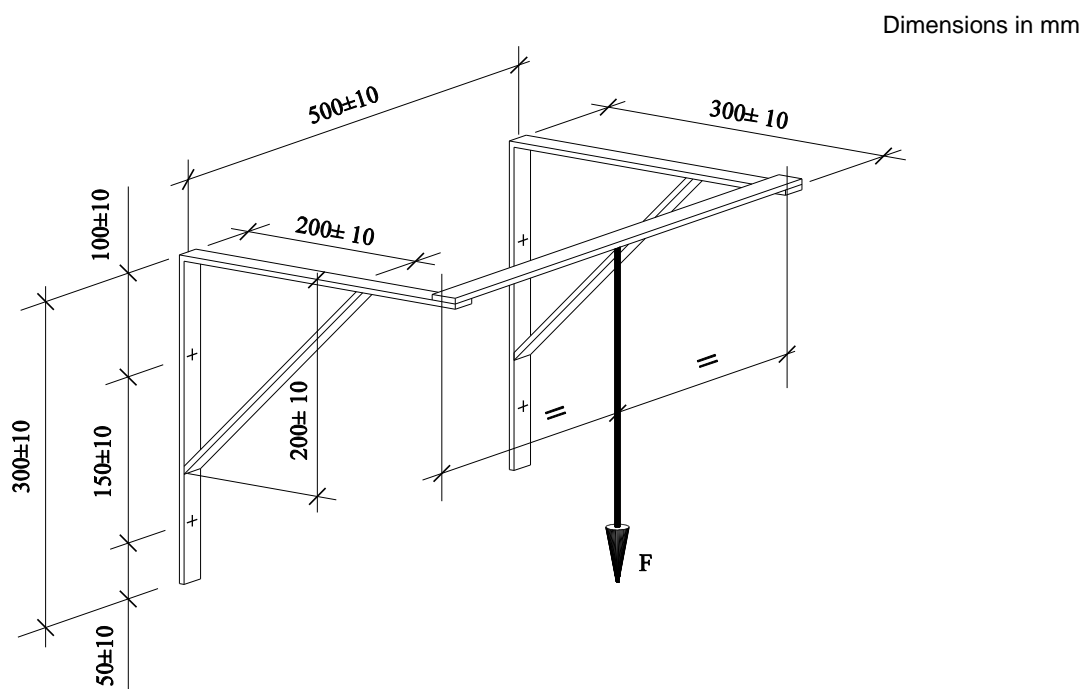

Figure 3: Principle of resistance to eccentric load test assembly

Different boards are to be used if more than one load is tested.

This fail/pass test has a successful result if the frame does not collapse. The test report shall show the eccentric vertical load that the board resisted and the failure mode (punch through of the frame, shear of mechanical fasteners, etc.). The test report shall list any visible damage (e.g. minor cracks).

When fixing systems are used that penetrate the fire protective board, the ETA shall contain the necessary precautions, ensuring that the fire protective assembly still fulfils the fire protective behaviour claimed. These specified precautions shall also be taken into account when assessing fire resistance (clause 2.2.1.1).

The ETA shall specify the eccentric vertical load that the board, installed in accordance with the manufacturer's specifications, resisted.

2.2.1.10 Adhesion

Note 4: This requirement has been placed under BWR4 for convenience, but is related to other requirements as well, in particular to BWR2.

This test method shall be carried out for adhered systems only and establishes bond strength between substrate, adhesive and fire protective board. This test shall be conducted on each substrate for which the fire protective kits based on boards is intended to be used.

The boards are adhered in accordance with the manufacturer's specifications.

The test is performed on five samples, measuring diameter 80 mm nominally, which are cut through the board and just into the substrate. The five samples may be drawn from one board. The metal plates are affixed to these areas with an appropriate adhesive (see **Figure 4**).

After allowing the adhesive to cure, in accordance with the ETA-applicant's specifications, the bond strength is measured with a dynamometer at a tensioning speed of (10 ± 1) mm/min.

The failure load of each test is expressed in MPa. The test results, the mode of failure and mean value are recorded in the test report.

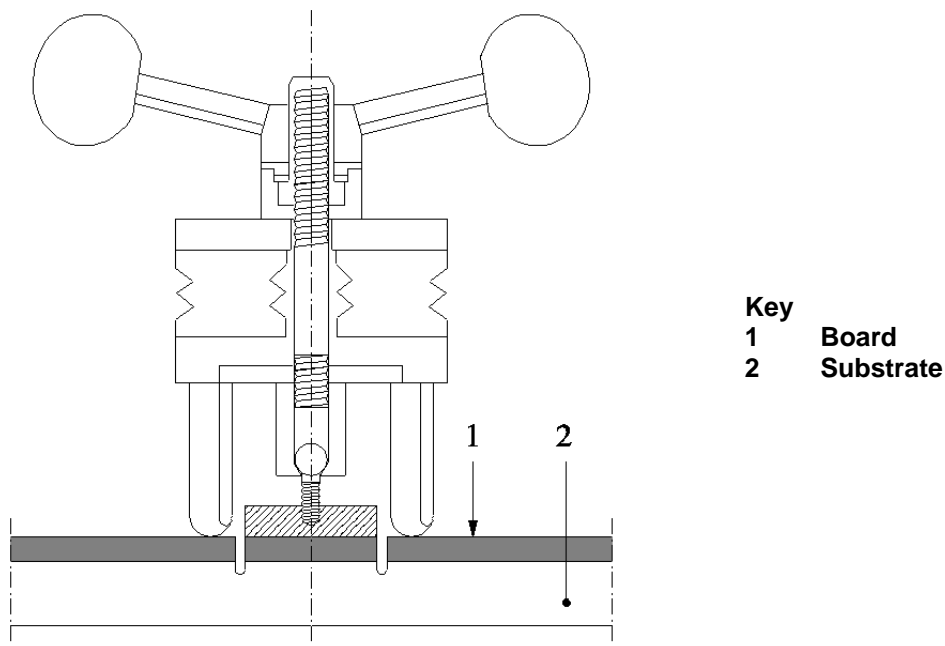

Figure 4: Principle of adhesion resistance test assembly

The ETA shall specify the mean value of five test results. The test result and the mode of failure may lead to restrictions on the use of the kit in the ETA.

2.2.1.11 Airborne sound insulation

Transmission of airborne sound of fire protective products in their end use condition shall be assessed in accordance with EN 10140-2. The measured airborne sound insulation is expressed as a single number rating, R_w , in accordance with EN ISO 717-1.

2.2.1.12 Sound absorption

Sound absorption of fire protective products in their end use condition shall be assessed in accordance with EN ISO 354.

The measured sound absorption is expressed as a single number rating, α_w in accordance with EN ISO 11654.

2.2.1.13 Impact sound insulation

Sound absorption of fire protective products in their end use condition shall be assessed in accordance with EN 10140-3.

The measured impact sound insulation is expressed as a single number rating in accordance with EN ISO 717-2.

2.2.1.14 Thermal insulation

The thermal transmittance/resistance of the fire protective product shall be determined based on declared values as quoted in European harmonised product standards or in ETAs.

If there is any discontinuity in the assembled system, e.g. a supporting frame or a fixing system, then the effect of thermal bridging shall be considered.

Specific thermal conductivity values either shall be tested in accordance with EN 12664, EN 12667 or EN 12939.

Alternatively, the thermal resistance and thermal transmittance (U-value) may be assessed according to EN ISO 8990:1996.

If necessary, the thermal resistance shall be calculated on the basis of EN ISO 6946:2008-04.

In principle, thermal bridges should be prevented. However, if such bridges do occur, their effect on the overall thermal performance shall be incorporated in the above mentioned thermal resistance calculations, taking into account results of thermal bridges calculation methods as described in EN ISO 14683, EN ISO 10211-1 and EN ISO 10211-2.

On the basis of the assessment method used, the corresponding tabulated or measured λ -value (in W/mK), the thermal resistance value R (in m²K/W) or the thermal transmittance coefficient U (in W/m²K), calculated, where relevant, in accordance with EN ISO 6946 shall be specified in the ETA. The source of the stated values or the standard used to determine the values shall be quoted in the ETA.

2.2.1.15 Moisture transfer

Where relevant, the water vapour transmission coefficient shall be determined on the basis of tabulated values as given in European harmonised product standards or ETAs. Specific water vapour transmission coefficient values shall be tested in accordance with EN ISO 12572 or EN 12086.

In these cases the tabulated or measured value of the water vapour transmission coefficient (μ -value) shall be specified. When the water vapour transmission coefficient is determined, the source of the values or the standard used to determine the values shall be quoted in the ETA.

2.2.2 Methods and criteria for assessing the performance of fire protective boards, slabs and mats

If not yet available, the performance characteristics for boards shall be verified in accordance with European technical specifications for the boards under consideration:

- harmonised European product standards as published by CEN (see Clause 4) or
- EAD's as published by EOTA,

unless this EAD considers product characteristics (incl. technical characterisation, serviceability and durability) that are not covered by those European technical specifications.

If such technical specifications are not available, the specifications referred to in this sub-clause shall be used for verification purposes.

All boards shall be dried to constant mass ensuring that the performances derived are reproducible. To prevent disproportionate costs, the method shall be as rapid as possible.

In normal circumstances, drying will take place in an oven at (105 ± 2) °C (method 1). If this might lead to chemical reactions which influence performance, the following methods may be applied.

- Conditioning method 2: in an oven at (40 ± 2) °C
- Conditioning method 3: in laboratory conditions (23 ± 2) °C and (50 ± 5) RH

Conditioning lasts until constant mass, i.e. until two subsequent weight measurements differ less than 0,1% over a (24 ± 1) h period or at least 28 days.

The ETA shall specify the conditioning method used.

2.2.2.1 Reaction to fire

One or more of the following options shall apply. However, certain end use applications of some products cannot be satisfactorily classified using Commission Delegated Regulation (EU) No 2016/364 (e.g. facades).

- The product (if the ETA is being issued for a fire protective board product) or individual kit components (if the ETA is being issued for a fire protective board kit), shall be tested, using the test method(s) relevant for the corresponding reaction to fire class, in order to be classified according to the Commission Delegated Regulation (EU) No 2016/364.
- The products or individual kit components are considered to satisfy the requirements for performance Class A1 of the characteristic reaction to fire, in accordance with the provisions of Decision 96/603/EC (as amended) without the need for further testing on the basis of their listing in that Decision. Alternatively, EC Decisions (e.g. Decision 2003/593/EC) may allow products or components to be classified without the further need for testing (CWFT).

The single burning item test shall be performed in accordance with EN 13823, using the mounting and fixing provisions presented in Annex B of this document.

Note 5: On a voluntary basis, the manufacturer may have other assemblies tested than the one presented in Annex B. Those test results shall be specified in the ETA.

The boards, slabs and mats shall be classified according to either Commission Delegated Regulation (EU) No 2016/364, Decision 96/603/EC (as amended, Class A1) or an appropriate Classified Without Further Testing (CWFT) Decision. The ETA shall mention the use assessment procedure and the reaction to fire classification.

2.2.2.2 Resistance to fire

Fire protective boards, slabs and mats are covered by this EAD, if at least one fire resistance classification is specified in the ETA, in accordance with the provisions in this EAD (see also clause 1.2.1 of this EAD). The part of the works or assembled system in which the fire protective product is intended to be incorporated, installed or applied shall be tested, using the test method relevant for the corresponding fire resistance class, in order to be classified according to the appropriate part of EN 13501.

For fire protective boards, slabs and mats which are part of normal building service installations or smoke control systems, the boards, slabs and mats shall be tested, using the test method relevant for the corresponding fire resistance application, in order to be classified according to EN 13501-3 or EN 13501-4.

Fire resistance tests shall be performed on assemblies, consisting of the board, slab or mat and other construction products (e.g. supporting framework, adhesive, fixing system and joint material) necessary to install an assembly, which is being used in practice by the manufacturer, in accordance with manufacturer's specifications.

The test report shall contain the product characteristics and installations details of all the products necessary to install the assembly.

The ETA shall contain a description of the tested assembly and the product characteristics of all the products or kit components that were necessary to install the assembly in the fire resistance test. Those product characteristics shall be considered as minimum product requirements to obtain the fire resistance classification.

This applies to the fire protective boards, but also to e.g. supporting frame, adhesives, fixing system or joint material, used in the assembly that was tested, even if they are not part of the kit.

Note 6: Manufacturers should be made aware that different classes may be required in the EEA Member States, depending on the intended use(-s) of the boards.

2.2.2.3 Durability

Durability assessment of the boards, slabs and mats according to this EAD leads to two classifications.

- Classification related to the working life
- Classification related to the intended climatic conditions

Taking into account that not all products and kits on the market are intended for a long working life, this EAD distinguishes three assessment approaches related to the intended working life:

- Working life of 25 years: a complete durability assessment that is done through artificial ageing. Satisfactory performance for the tests (see clause 2.2.2.4) leads to a working life of the product of 25 years. The intended weather exposure category depends on the satisfactory performance for the following tests.
- Working life of 10 years: Favourable assessment for the basic durability assessment (see clause 2.2.2.5)
- Working life of 10 years: Unfavourable assessment for the basic durability assessment (see clause 2.2.2.5), but sufficient documented proof to demonstrate experience of 10 years favourable performance (see clause 2.2.2.6).

In accordance with clause 1.2.3, four use categories have been distinguished:

- Type X: the assessment specified in clauses 2.2.2.5 (basic durability assessment) and all assessment methods specified in clause 2.2.2.4 (Extended durability assessment) leads to a favourable result.
- Type Y: at least the assessment specified in clauses 2.2.2.5 (basic durability assessment) and 2.2.2.4.3 (freeze/thaw resistance) leads to a favourable result.
- Type Z1: at least the assessment specified clauses 2.2.2.5 (basic durability assessment), 2.2.2.4.1 (resistance to deterioration caused by water) and 2.2.2.4.2 (resistance to soak/dry) lead to a favourable result.
- Type Z2: at least the assessment specified in clause 2.2.2.5 (basic durability assessment) leads to a favourable result.

The assessment in accordance with clauses 2.2.2.4, 2.2.2.5 and 2.2.2.6 leads to the statement in the ETA of the use category(-ies) achieved. The individual assessment results obtained shall not be stated.

Note 1: EN 12467:2012, which is the basis for the above mentioned tests, provides pass/fail criteria. These criteria have been established for the product covered by that standard and may therefore, not be applicable for the products covered by this EAD. Because the EAD covers a wide variety of products, it is at present not possible to fix uniform criteria in this EAD. If the assessment criteria are not applicable for a product, a separate EAD might be necessary.

Note 2: Other paragraphs (clauses 2.2.1.5, 2.2.2.8 and 2.2.2.9) in this EAD are part of the overall Assessment Body's assessment leading to determining the weather exposure type(-s).

2.2.2.4 Extended durability assessment

2.2.2.4.1 Resistance to deterioration caused by water

This test needs to be performed only for intended uses: Types X and Z1. Types Y and Z2 shall be tested if more than accidental wetting is to be expected.

The boards, slabs and mats shall be tested in accordance with EN 12467:2012, clause 7.3.5.

When tested in accordance with EN 12467:2012, clause 7.3.5, the ratio RL as defined in EN 12467:2012, clause 7.3.5.4 shall be the basis for determining the use category(-ies) achieved.

2.2.2.4.2 Resistance to soak/dry

This test needs to be performed only for intended uses: Type X and Z1. Types Y and Z2 shall be tested if more than accidental wetting is to be expected.

The boards, slabs and mats shall be tested in accordance with EN 12467:2012, clause 7.3.6.

When tested in accordance with EN 12467:2012, clause 7.3.6, the ratio RL as defined in EN 12467:2012, clause 7.3.6.4 shall be the basis for determining the use category(-ies) achieved. The ETA shall state the number of soak/dry cycles.

2.2.2.4.3 Resistance to freeze/thaw

This test needs to be performed only for intended uses: Types X and Y. Types Z1 and Z2 shall be tested if frost is to be expected inside the building.

The boards, slabs and mats shall be tested in accordance with EN 12467:2012, clause 7.4.1. For type Y, Annex D of this EAD replaces paragraphs 3 to 8 of EN 12467:2012, subclause 7.4.1.3.

When tested in accordance with EN 12467:2012, clause 7.4.1, the ratio RL as defined in EN 12467:2012, clause 7.4.1.4 and the number of freeze/thaw cycles shall be the basis for determining the use category(-ies) achieved.

2.2.2.4.4 Resistance to heat/rain

This test needs to be performed only for intended uses: Type X.

The boards, slabs and mats shall be tested in accordance with EN 12467:2012, clause 7.4.2.

When tested in accordance with EN 12467:2012, clause 7.4.2, any visible cracks, delamination or other defects in the boards, slabs or mats shall not be of such a degree as to affect their intended use.

2.2.2.5 Basic durability assessment

Satisfactory performance for the following tests leads to a declaration of the working life of the product of 10 years, for internal uses only (types Z1 and Z2). Basic durability assessment is done through indirect testing, i.e. the measurement of "proxy" characteristics that are correlated to actual performance and hence durability.

- Flexural strength: see clause 2.2.2.9.
- Dimensional stability: see clause 2.2.2.10.
- Tensile strength perpendicular to the plane of the board, slab or mat: test to be performed in accordance with EN 319 (for boards) or EN 1607 (for slabs and mats).
- Tensile strength parallel with the plane of the board, slab or mat: test to be performed in accordance with EN 789 (for boards) or EN 1608 (for slabs and mats).
- Compressive strength of the board, slab or mat: test to be performed in accordance with EN 789 (for boards) or EN 826 (for slabs and mats).

Test results shall be assessed in accordance with relevant technical specifications (harmonised standards or EADs). Note: With the term "proxy characteristics", product properties are being referred to, through which it is possible, by indirect testing, to obtain a basis of assessment of the characteristic durability, without the use of direct testing, natural or artificial weathering or ageing.

When the durability assessment through "proxy characteristics" shows unsatisfactory performance, further supporting information from the manufacturer (e.g. references) is required. Small scale tests after artificial ageing might be necessary. Until harmonized European small scale tests are available, they are to be performed according to methods accepted in the Member State of use of the product/kit.

2.2.2.6 Demonstration of experience of 10 years favourable performance

In case the product or kit component does not meet the requirements as set out in clause 2.2.2.4 and clause 2.2.2.5, the ETA-applicant has the opportunity to provide documented proof that the product under consideration has been used for at least 10 years.

The following information is necessary:

- Evidence showing that the product used in the works has been exposed to conditions specified in the claimed ETA scope
- Evidence showing that the product used in works has been manufactured in accordance with the same manufacturing specifications
- Evidence from at least 5 different sites (more may be required if a number of different installation techniques, intended exposures and/or climates are claimed)
- Additional evidence may be, for example, natural weathering/ageing data which give a direct indication of durability or which enable performance tests to be carried out on aged material, thus allowing the degradation in performance to be determined.

The extent and sufficiency of the documented proof provided will define the intended use climatic conditions specified in the ETA, for a working life of 10 years.

The ETA shall specify which evidence has been used for the assessment.

2.2.2.7 Adhesion of finishings

The adhesion of finishings shall be determined in accordance with EN 24624.

The adhesion of finishings shall be stated in accordance with EN 24624

2.2.2.8 Water permeability

When the boards, slabs and mats that are intended to be used in climatic conditions X, they shall be tested in accordance with EN 12467:2012, clause 7.3.3. Traces of moisture may appear on the under surface of the board, slab or mat, but in no instance shall there be any formation of drops of water. Only the boards, slabs and mats that meet the requirement may claim water tightness.

2.2.2.9 Flexural strength

The boards, slabs and mats that are intended to be used in climatic conditions Y and X shall be tested in accordance with EN 12467:2012, clause 7.3.2 (for boards) or EN 12089 (for slabs and mats). When the applicant claims flexural strength for boards, slabs and mats that are intended to be used in climatic conditions Z₂ and Z₁ they shall be tested in accordance to the same test procedures.

For boards: when tested in accordance with EN 12467:2012, clause 7.3.2, the mean modulus of rupture (MOR) of the sheets, expressed in MPa, shall be specified in the ETA.

For slabs and mats: when tested in accordance with EN 12089, the conventional bending strength, expressed in kPa, shall be specified in the ETA.

2.2.2.10 Dimensional stability

The boards, slabs and mats shall be tested in accordance with EN 318 (for boards) or EN 1604 (for slabs and mats).

Assessment results shall be stated in the ETA.

2.2.2.11 Thermal resistance

For boards, slabs and mats thermal conductivity shall be based upon measurements carried out in accordance with EN 12667 or if relevant EN 12939 or EN 993-14.

The thermal performance of fire protective boards which may also be used for their thermal insulation purposes, i.e. products with a declared thermal resistance higher than 0,25 m².K/W or a declared thermal conductivity at 10 °C lower than 0,060 W/(m.K), shall be determined and verified in accordance with EN ISO 13787.

The measured value of the thermal conductivity (λ -value) shall be stated in the ETA.

2.2.2.12 Water vapour transmission coefficient

The boards, slabs and mats shall be tested in accordance with EN ISO 12572 (for boards) or EN 12086 (for slabs and mats). This characteristic is also closely related to WBR3.

The measured value of the water vapour transmission coefficient (μ -value) shall be stated in the ETA.

2.2.2.13 Technical characterisation

Note: The Assessment Body may require additional information and may adopt other verification methods.

- a) Length, Width

The dimensions shall be specified in accordance with EN 12467:2012, clause 5.3.2 (for boards) or EN 822 (for slabs and mats). Length(-s) and width(-s) shall be specified in the ETA

b) Thickness

The thickness shall be specified in accordance with EN 12467:2012, clause 5.3.3 (for boards) or EN 823 (for slabs and mats). Thickness(-es) shall be specified in the ETA.

c) Dimensional tolerances

The dimensional tolerances shall be specified in accordance with EN 12467:2012, clause 5.3.4 (for boards) or EN 13162 (for mats) or EN 13467 (for slabs). Dimensional tolerances shall be specified in the ETA.

d) Shape

The shape shall be specified in accordance with EN 12467:2012, clause 5.3.5 (for boards) or EN 824 (for slabs and mats). Shape(-s) shall be specified in the ETA.

e) Apparent density

The apparent density shall be specified in accordance with EN 12467:2012, clause 5.4.2 (for boards) or EN 1602 (for slabs and mats). The (apparent) density shall be specified in the ETA.

f) Finishings

Information of all finishings shall be given in the ETA, either by reference to:

- Harmonised product standards
- ETAs, based on other EADs.
- Non-harmonised European product standards
- Non-harmonised International product standards
- Descriptive technical characterisation, identifying the products by their composing materials and their function

In any case, significant properties (mechanical, physical, chemical, ...) and their tolerances shall be given. In those cases where the above listed product specifications do not specify test methods for technical characterisation, the test methods used shall be based on European standards, International standards, EOTA Technical Reports, UEAtc Guidelines, Nordtest standards or RILEM test methods.

Ultimately, a formulation, a manufacturer's specific reference or a similar unique specification of the finishing(-s) may also be stated.

Note: Finishings based on reactive materials are covered by Annex C.

All finishings shall technically be fully characterised in the ETA in accordance to this clause.

2.2.3 Methods and criteria for assessing the performance of the mechanical fasteners

The performance characteristics for mechanical fasteners shall be verified in accordance with European technical specifications for the mechanical fasteners under consideration:

- harmonised European product standards as published by CEN (see Annex A) or
- EADs as published by EOTA,

unless this EAD considers product characteristics (incl. technical characterisation, serviceability and durability) that are not covered by those European technical specifications.

If such technical specifications are not available, the specifications referred to in this sub-clause shall be used for verification purposes.

The kit components shall only be subjected to the assessment methods specified below if the corresponding characteristics are relevant for the component under consideration and as far as relevant for its assessment.

2.2.3.1 Reaction to fire

- The individual kit components shall be tested, using the test method(s) relevant for the corresponding reaction to fire class, in order to be classified according to Commission Delegated Regulation (EU) No 2016/364.
- The individual kit components are considered to satisfy the requirements for performance Class A1 of the characteristic reaction to fire, in accordance with the provisions of EC Decision 96/603/EC (as amended) without the need for further testing on the basis of their listing in that Decision. Alternatively, EC Decisions (e.g. Decision 2003/593/EC) may allow products or components to be classified without the further need for testing (CWFT).

The mechanical fasteners shall be classified according to either Commission Delegated Regulation (EU) No 2016/364, Decision 96/603/EC (as amended, Class A1) or an appropriate Classified Without Further Testing (CWFT) Decision.

2.2.3.2 Durability

The behaviour of mechanical fasteners may be influenced by corrosion and the degradation of the coating. Therefore, the following shall be considered:

2.2.3.2.1 Corrosion

No special test conditions are required, if the conditions given in this clause are complied with. If the mechanical fasteners are to be used in particularly aggressive conditions or atmospheres with extreme chemical pollution, special considerations including testing are necessary, taking into account the environmental conditions and the available experience.

The assessment/testing required with respect to corrosion resistance shall be dependent upon the specification of the mechanical fastening system in relation to its use. Supporting evidence that corrosion will not occur is not required if the mechanical fasteners are protected against corrosion of steel parts, as set out below:

- a) Mechanical fasteners for use in structures subject to external atmospheric exposure or exposure in permanently damp internal conditions

The metal parts of the mechanical fasteners shall be made of an appropriate grade of stainless steel. The grade of stainless steel appropriate for the various service environments (marine, industrial, etc.) shall be in accordance with existing rules. Grade A4 of EN ISO 3506 or equivalent may be used under internal or other environmental conditions if no particularly aggressive conditions exist.

However, in particularly aggressive conditions such as permanent, alternating immersion in seawater or the splash zone of seawater, chloride atmosphere of indoor swimming pools or atmosphere with extreme chemical pollution (e.g. in desulphurisation plants or road tunnels, where de-icing materials are used) special considerations shall be given to corrosion resistance. According to current experience, in general the types of stainless steel given above will not have sufficient corrosion resistance in those aggressive conditions.

- b) Mechanical fasteners intended for use in structures subject to dry, internal conditions

In general, no special corrosion protection is necessary for steel parts as coatings provided for preventing corrosion during storage prior to use, to ensure proper functioning (e.g. a zinc coating with a minimum thickness of 5 microns) is considered sufficient. Malleable cast iron parts in general, e.g. type B32-12 and W40 05 to ISO 5922 do not require any protection.

Where a form of protection (material or coating) other than those mentioned above is specified, it will be necessary to provide evidence in support of its effectiveness in the defined service conditions; with due regard to the aggressiveness of the conditions concerned.

If mechanical fastening systems involve the use of different metals, these shall be electrolytically compatible with each other. In dry internal conditions, carbon steel is compatible with malleable cast iron.

2.2.3.2.2 Coating

The durability of the coating that ensures the load-bearing behaviour of the mechanical fasteners shall be shown. No special test conditions are given in this EAD for checking the durability of any coating, because it depends on the type of coating. Appropriate tests shall be decided on by the responsible Assessment Body.

The following environmental conditions shall be taken into account in assessing durability of coatings:

Dry internal conditions:

- high alkalinity (pH > 13,2)
- temperature in range – 5 °C to + 40 °C

Other environmental conditions:

- high alkalinity (pH > 13,2)
- temperature in range – 40 °C to + 80 °C
- condensed water
- chlorides
- sulphur dioxide
- nitrogen oxide
- ammonia

Zinc coatings (electroplated or hot dip galvanized) need not be subjected to testing if used under dry internal conditions.

Assessment of the durability of the coating is based on the type of coating and the intended conditions of use (i.e. dry internal or external conditions).

2.2.3.3 Pull-out resistance of mechanical fasteners

This test method shall be carried out for mechanically fixed systems only and establishes the pull-out resistance of a mechanical fastener. This test shall be conducted on each substrate for which the fire protective kits based on boards is intended to be used.

The test is carried out on 5 sample substrates, each measuring at least (300 ± 20) mm nominally.

The apparatus consists of:

- a dynamometer,
- a support as shown in figure 5
- standard substrates: depending on the substrates the kit is intended to be fastened to, pull-out tests shall be performed on the following substrates:
 - Concrete containing granules of 8 to 10 mm in accordance with EN 1766 (type MC 0,40)
 - Category I clay units in accordance with EN 771-1.
 - Category I calcium silicate units in accordance with EN 771-2.
 - Category I aggregate concrete units (dense and lightweight aggregate) in accordance with EN 771-3.
 - Category I autoclaved aerated concrete units in accordance with EN 771-4.
 - Category I manufactured stone units in accordance with EN 771-5.
 - Category I dimensioned natural stone units in accordance with EN 771-6.
 - Continuously hot-dip zinc coated structural steel sheet, nominally 1,00mm thick, type S280 GD, in accordance with EN 10147
 - Oriented strand board (OSB), type OSB/2, thickness 15 mm in accordance with EN 300.

The sample boards and mechanical fasteners are conditioned, at $(23 \pm 2) ^\circ\text{C}$ and $(50 \pm 5) \%RH$, until constant mass, i.e. until two subsequent measurements, with a minimum interval of 24 h, differ less than 0,1 %.

The mechanical fastener is installed in accordance with the manufacturer's specifications.

The test shall be carried out at $(20 \pm 10) ^\circ\text{C}$ and $(50 \pm 20) \%RH$. The tensile strength for pulling out the mechanical fastener shall be measured with a dynamometer. The tensioning speed is $(20 \pm 2) \text{ mm/min}$. The application of the load has to be controlled.

The pull-out resistance of each test is expressed in N. The test results, the mode of failure and mean value are recorded in the test report. The ETA shall specify the mean value of the five results.

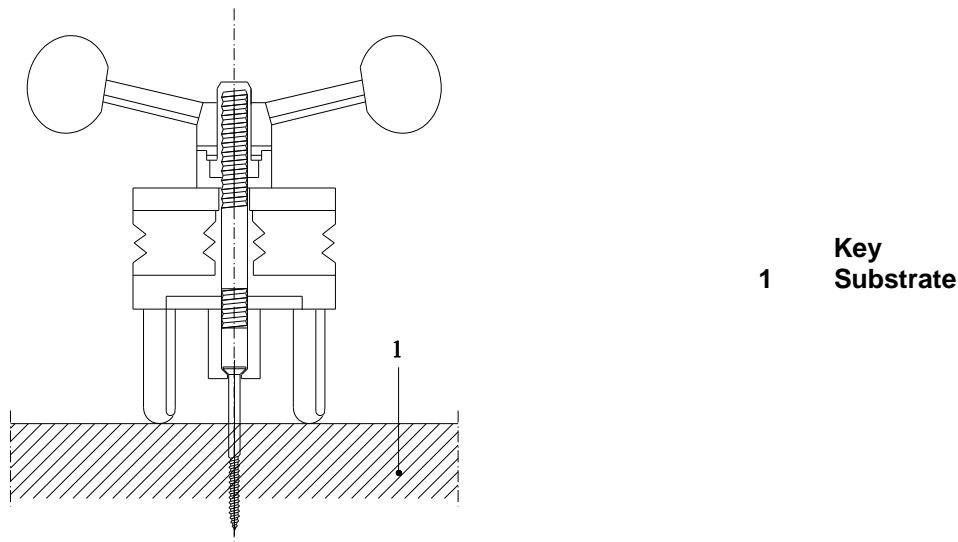

Figure 5: Principle of pull-out test assembly

2.2.3.4 Technical characterisation

Information on the following properties shall be detailed in the ETA, for:

- Product description (e.g. self-tapping screw, self-drilling screw and drywall screw)
- Type of metal and protection
- Dimensions and design of the mechanical fastener

Note: The Assessment Body may require additional information and may adopt other verification methods.

2.2.4 Methods and criteria for assessing the performance of the adhesives

The performance characteristics for adhesives shall be verified in accordance with European technical specifications for the adhesives under consideration:

- harmonised European product standards as published by CEN (see Annex A) or
- EADs as published by EOTA,

unless this EAD considers product characteristics (incl. technical characterisation, serviceability and durability) that are not covered by those European technical specifications.

If such technical specifications are not available, the specifications referred to in this sub-clause shall be used for verification purposes.

Kit components shall only be subjected to the assessment methods specified below if the corresponding characteristics are relevant for the component under consideration and as far as relevant for its performance in the intended use(-s).

2.2.4.1 Reaction to fire

One or more of the following options shall apply.

- The individual kit components shall be tested, using the test method(s) relevant for the corresponding reaction to fire class, in order to be classified according to Commission Delegated Regulation (EU) No 2016/364.
- The products or individual kit components are considered to satisfy the requirements for performance Class A1 of the characteristic reaction to fire, in accordance with the provisions of EC Decision 96/603/EC (as amended) without the need for further testing on the basis of their listing in that Decision. Alternatively, EC Decisions (e.g. Decision 2003/593/EC) may allow products or components to be classified without the further need for testing (CWFT).

Adhesives shall be classified according to either Commission Delegated Regulation (EU) No 2016/364, Decision 96/603/EC (as amended, Class A1) or an appropriate Classified Without Further Testing (CWFT) Decision.

2.2.4.2 Durability and serviceability requirements: Determination of freeze/thaw stability

The resistance to freeze/thaw shall be tested in accordance with EN 1239.
The measured values derived from the test methods shall be specified in the ETA.

2.2.4.3 Mechanical resistance and stability (of adhesives)

2.2.4.3.1 Peel resistance

The peel resistance shall be tested in accordance with EN 1372.
The measured values derived from the test methods and the mode of failure shall be specified in the ETA.

2.2.4.3.2 Shear strength

The shear resistance shall be tested in accordance with EN 1373.
The measured values derived from the test methods and the mode of failure shall be specified in the ETA.

2.2.4.4 Technical characterisation

a) Product description

The type of Adhesive shall be specified in accordance with EN 923.
The product description shall be specified in the ETA.

b) Determination of viscosity

The viscosity shall be tested in accordance with EN 12092.
The viscosity shall be specified in the ETA.

c) Determination of density

The density shall be tested in accordance with EN 542.
The density shall be specified in the ETA.

Note: The Assessment Body may require additional information and may adopt other verification methods.

2.2.5 Methods and criteria for assessing the performance of the jointing material

The performance characteristics for jointing materials shall be verified in accordance with European technical specifications for the jointing materials under consideration:

- harmonised European product standards as published by CEN (see Annex A) or
- EADs as published by EOTA,

unless this EAD considers product characteristics (incl. technical characterisation, serviceability and durability) that are not covered by those European technical specifications.

If such technical specifications are not available, the specifications referred to in this sub-clause shall be used for verification purposes.

Kit components shall only be subjected to the verification methods specified below if the corresponding characteristics are relevant for the component under consideration and as far as relevant for its performances in the intended use(-s).

2.2.5.1 Reaction to fire

One or more of the following options shall apply.

- The individual kit components shall be tested, using the test method(s) relevant for the corresponding reaction to fire class, in order to be classified according to Commission Delegated Regulation (EU) No 2016/364.
- The products or individual kit components are considered to satisfy the requirements for performance Class A1 of the characteristic reaction to fire, in accordance with the provisions of EC Decision 96/603/EC (as amended) without the need for further testing on the basis of their listing in that Decision. Alternatively, EC Decisions (e.g. Decision 2003/593/EC) may allow products or components to be classified without the further need for testing (CWFT).

The jointing materials shall be classified according to either Commission Delegated Regulation (EU) No 2016/364, Decision 96/603/EC (as amended, Class A1) or an appropriate Classified Without Further Testing (CWFT) Decision.

2.2.5.2 Durability

2.2.5.2.1 Durability

Depending on the nature of the jointing material, the following assessment methods shall be used:

- Unformed materials, which remain flexible (e.g. sealants): The jointing material shall be tested in accordance with EN ISO 11431.
- Preformed materials (e.g. joint strips): EN 12365-1
- Metals: see clause 2.2.3.2
- Plastics: The jointing material shall be tested in accordance with EN 12365-1
- Unformed materials, which become rigid over time (e.g. mortars): The durability shall be determined in accordance with prEN 1015-20
- Loose fill materials (e.g. mineral wool): The dimensional stability shall be determined in accordance with EN 1604.

The ETA shall mention the results of the assessment.

2.2.5.2.2 Serviceability

2.2.5.2.2.1 Tensile strength

Depending on the nature of the jointing material, the following assessment methods shall be used:

- Unformed materials, which remain flexible (e.g. sealants): The jointing material shall be tested in accordance with EN ISO 8339, at 23°C and -20°C. If claimed, the test may also be performed at -40°C;
- Preformed materials (e.g. joint strips): EN 12365-1;
- Metals: The jointing material shall be tested in accordance with EN 10002-1;
- Plastics: The jointing material shall be tested in accordance with EN ISO 527-1 and EN ISO 527-2;
- Unformed materials, which become rigid over time (e.g. mortars): The jointing material shall be tested in accordance with EN 1015-11.

The ETA shall mention the results of the assessment.

2.2.5.2.2.2 Adhesion/cohesion

Depending on the nature of the jointing material, the following assessment methods shall be used:

- Unformed materials, which remain flexible (e.g. sealants):
 - At variable temperatures: The jointing material shall be tested in accordance with EN ISO 9047 and assessed as defined in clause 7 of EN ISO 111600. This assessment is not required when the ETA states the temperature range in which the fire protective board kits shall be used under normal conditions.
 - After water immersion: The jointing material shall be tested in accordance with EN ISO 10590 and assessed as defined in clause 7 of EN ISO 111600. This assessment is not required when the ETA declares that the fire protective board kits shall not be exposed to any moisturising.
- Preformed materials (e.g. joint strips): The jointing material shall be tested in accordance with EN 12365-1.
- Unformed materials, which become rigid over time (e.g. mortars): The jointing material shall be tested in accordance with EN 1015-12.
- Loose fill materials (e.g. mineral wool): The tensile strength, perpendicular to its faces, shall be determined in accordance with EN 1607.

The ETA shall mention the results of the assessment.

2.2.5.3 Technical characterisation

- Product description: information regarding the nature of the product (e.g. silicone, polyurethane, 1 or 2 components) and its application method.
- Unformed materials, which remain flexible (e.g. sealants) shall be classified in accordance with EN ISO 11600.
- Preformed materials (e.g. joint strips):
- Metals shall be technically characterised in accordance with EN 10020 or EN 10088.
- Plastics shall be technically characterised in accordance with relevant European or international product specification standards
- Unformed materials, which become rigid over time (e.g. mortars) shall be technically characterised in accordance with EN 998 1 or EN 998-2.
- Loose fill materials (e.g. mineral wool) shall be technically characterised in accordance with EN 13162.

Note: The Assessment Body may require additional information and may adopt other verification methods.

2.2.6 Methods and criteria for assessing the performance of the insulation products

This clause of the EAD provides assessment methods for insulation as a fire protective kit component. Insulation products that are intended to be put on the market as fire protective boards, slabs or mats as a single product are covered by clause 2.2.2.

The performance characteristics for insulation products shall be verified in accordance with European technical specifications for the products under consideration:

- harmonised European product standards as published by CEN (see Annex A) or;
- EADs as published by EOTA,

unless this EAD considers product characteristics (incl. technical characterisation, serviceability and durability) that are not covered by those European technical specifications.

If such technical specifications are not available, the specifications referred to in this sub-clause shall be used for verification purposes.

Kit components shall only be subjected to the verification methods specified below if the corresponding characteristics are relevant for the component under consideration and as far as relevant for its performances in the intended use(-s).

2.2.6.1 Reaction to fire

One or more of the following options shall apply. However, certain end use applications of some products may not be able to be satisfactorily classified using Commission Delegated Regulation (EU) No 2016/364 (e.g. facades).

- The individual kit components shall be tested, using the test method(s) relevant for the corresponding reaction to fire class according to EN 13501-1, in order to be classified according to Commission Delegated Regulation (EU) No 2016/364.
- The products or individual kit components are considered to satisfy the requirements for performance Class A1 of the characteristic reaction to fire, in accordance with the provisions of EC Decision 96/603/EC (as amended) without the need for further testing on the basis of their listing in that Decision. Alternatively, EC Decisions (e.g. Decision 2003/593/EC) may allow products or components to be classified without the further need for testing. (CWFT).

The insulation products shall be classified according to either Commission Delegated Regulation (EU) No 2016/364, Decision 96/603/EC (as amended, Class A1) or an appropriate Classified Without Further Testing (CWFT) Decision.

2.2.6.2 Durability

2.2.6.2.1 Moisture resistance

The short term water absorption by partial immersion shall be determined in accordance with EN 1609 including any facings or coatings.

The water absorption rate in kg/m² shall be specified- in the ETA.

2.2.6.2.2 Dimensional stability under constant normal laboratory conditions

Dimensional stability under constant normal laboratory conditions (23 °C/50 % relative humidity) shall be determined in accordance with EN 1603.

The relative changes in length shall be specified in the ETA.

2.2.6.3 Water vapour transmission coefficient

The boards and slabs shall be tested in accordance with EN 12086. This characteristic is also closely related to WBR3.

The measured value of the water vapour transmission coefficient (μ -value) shall be specified in the ETA.

2.2.6.4 Thermal insulation

For boards, slabs and mats thermal conductivity shall be based upon measurements carried out in accordance with EN 12667 or if relevant EN 12939 or EN 993-14.

The measured value of the thermal conductivity at ambient temperature (λ -value) shall be specified in the ETA.

2.2.6.5 Technical characterisation

a) Length, Width

The dimensions shall be specified in accordance with EN 822. Length(-s) and width(-s) shall be declared in the ETA.

b) Thickness

The thickness shall be specified in accordance with EN 823. Thickness(-es) shall be declared in the ETA.

c) Dimensional tolerances

The dimensional tolerances shall be specified in accordance with the relevant product standard or ETA. Dimensional tolerances shall be declared in the ETA.

d) Shape

The shape shall be specified in accordance with EN 824. Shape(-s) shall be declared in the ETA.

e) Density

The (apparent) density shall be determined in accordance with EN 1602. The (apparent) density shall be declared in the ETA.

f) Finishings

All finishings shall be technically characterised, either by reference to:

- Harmonised product standards;
- ETA's, based on other EAD's;
- Non-harmonised European product standards;
- Non-harmonised International product standards;
- Descriptive technical characterisation, identifying the products by their composing materials and their function.

In any case, significant properties (mechanical, physical, chemical, ...) and their tolerances shall be given. In those cases where the above listed product specifications do not specify test methods for technical characterisation, test methods used, shall be based on European standards, International standards, EOTA Technical Reports, UEAtc Guidelines, Nordtest standards or RILEM test methods.

Ultimately, a formulation, a manufacturer's specific reference or a similar unique specification for the finishings may also be accepted.

All finishings shall technically be fully characterised in accordance with this clause.

Note: The Assessment Body may require additional information and may adopt other verification methods.

2.2.7 Methods and criteria for assessing the performance of the profiles, framework and studs

The performance characteristics for profiles, framework, studs, etc. shall be verified in accordance with European technical specifications for the products under consideration:

- harmonised European product standards as published by CEN (see Annex A) or;
- EADs as published by EOTA,

unless this EAD considers product characteristics (incl. technical characterisation, serviceability and durability) that are not covered by those European technical specifications.

If such technical specifications are not available, the specifications referred to in this sub-clause shall be used.

Kit components shall only be subjected to the verification methods specified below if the corresponding characteristics are relevant for the component under consideration and as far as relevant for its performances in the intended use(-s).

2.2.7.1 Reaction to fire

One or more of the following options shall apply. However, certain end use applications of some products may not be able to be satisfactorily classified using Commission Delegated Regulation (EU) No 2016/364(e.g. facades).

- The individual kit components shall be tested, using the test method(s) relevant for the corresponding reaction to fire class according to EN 13501-1, in order to be classified according to Commission Delegated Regulation (EU) No 2016/364.
- The products or individual kit components are considered to satisfy the requirements for performance Class A1 of the characteristic reaction to fire, in accordance with the provisions of EC Decision 96/603/EC (as amended) without the need for further testing on the basis of their listing in that Decision. Alternatively, EC Decisions (e.g. Decision 2003/593/EC) may allow products or components to be classified without the further need for testing. (CWFT)

The insulation products shall be classified according to either Commission Delegated Regulation (EU) No 2016/364, Decision 96/603/EC (as amended, Class A1) or an appropriate Classified Without Further Testing (CWFT) Decision.

2.2.7.2 Durability

If supporting profiles or a framework are components of the kit, then these shall also be assessed, with regard to durability, on the basis of European (CEN) or International standards (ISO). Because such components may be designed in a large number of possibilities and materials, the assessment method shall be considered on a case-by-case basis, taking into account that a number of verification methods already foresee the incorporation of these components in a number of assembly tests (e.g. SBI, fire resistance, impact resistance).

In order to demonstrate the durability of the supporting framework, the Assessment Body may make use of information derived from documented sources, such as listed experience or previous approval or assessment procedures. The file shall make clear under what conditions of climate and product usage the satisfactory experience has been gained.

The following references shall be used for aluminium, steel or timber supporting framework:

- Aluminium: The corrosion protection of aluminium supporting framework shall be classified in accordance with EN 1396.
- Steel: The corrosion protection of steel supporting framework shall be classified in accordance with EN 10327 or EN 10152. Coatings of steel parts with zinc compatible organic coating shall be verified according to EN ISO 12944-3 (paints, coatings) or of steel parts with equivalent coil coating according to EN 10169-1.

- Timber: Compliance of the members of timber framework with the requirements of section 4 of EN 1995-1-1 shall be assessed.

The ETA shall contain details of the supporting framework materials and the means by which their durability has been proven. Where the evidence is from previous assessments or from experience it shall be clear over what period the evidence has been gathered and under what circumstances the material and/or its corrosion protection or preservative treatment has proved satisfactory. Comment shall be made on any hazard that might arise in particular exposure conditions e.g. marine or industrial areas.

2.2.7.3 Mechanical resistance and stability

2.2.7.3.1 General

The load-bearing capacity of the supporting framework of a kit shall be determined taking account of EN 1990:2002 either by calculation, testing or a combination of calculation assisted by testing (see clauses 5.7.4.1.2 to 5.7.4.1.4).

However, usually, the supporting framework has no load-bearing function and only transmits loads onto structural elements (e.g. ceilings, walls).

In such cases, the mechanical resistance of the supporting framework may be considered satisfactory, if the assembly tests required in this EAD (e.g. SBI, resistance to fire, impact resistance) have been performed with satisfactory result.

Extended application and engineering knowledge may be used to assess supporting framework, profiles, etc. that are made out of the same material and have comparable intended use(-s).

Usually, the performance of the supporting framework will have been determined by calculations, testing or a combination of calculation and testing. Alternatively, adequate information regarding the physical properties and dimensions, in accordance with 2.2.7.5, shall be provided.

2.2.7.3.2 Calculation

The supporting framework shall be calculated in accordance with the following, depending upon the materials used:

- EN 1993: Design of steel structures;
- EN 1995: Design of timber structures;
- EN 1999: Design of aluminium structures.

The properties of structural components shall be specified in the ETA with regard to the need of fulfilling the requirements applicable to the end use of the component.

This may be done by expressing the properties in terms of:

- characteristic values for strength and other cross section properties from which the load-bearing capacities of the assembled kit installed in the works may be calculated, or.
- design values provided that the Nationally Determined Parameters (NDP) applicable to works have been taken into account by appropriate levels and classes, which correspond to sets of NDPs.

Any Nationally Determined Parameters (NDP) used shall be declared.

2.2.7.3.3 Testing

Where the supporting framework cannot be calculated or where a testing approach is preferred, the profiles are tested on a case-by-case approach, taking into account the particular design and intended use.

Only test methods which are part of this EAD, may be used, or, alternatively, those specified in European standards (CEN), International standards (ISO), EOTA Technical Reports, UEAtc Guidelines, Nordtest

standards or RILEM test methods⁴. If such alternatives are being used, the ETA shall specify the method in sufficient detail (the specification's reference and edition, and, if relevant, any deviations made, compared with the specified method).

Where bending resistance is required, the test method specified in EN 13964:2004, clause 5, shall be used.

2.2.7.3.4 Verification assisted by testing

Where calculation rules or material properties given in the referenced Eurocodes according to clause 2.2.7.3.2 are not sufficient or where economy may result from tests on the products under consideration, part of the design procedure may be performed on the basis of tests. This design assisted by testing shall be done according to Annex D of EN 1990:2002.

Where the performance of the supporting framework has been determined by testing or a combination of calculation and testing, then the principles of the relevant structural Eurocodes shall be followed to determine an overall performance relating to strength and stiffness.

The statistical analysis of the test results to determine the characteristic value is to be undertaken according to EN 1990:2002.

2.2.7.4 Thermal insulation

Usually, the manufacturer will allow EN ISO 10456 to be used to determine the thermal resistance of the supporting framework.

Where a manufacturer makes specific claims for the thermal performance of a fire protective board kit, the thermal characteristics of the frame members may be determined using relevant tests and calculations, e.g. given in EN 12412-2 and EN ISO 10077-2.

Only where the manufacturer claims thermal performance the thermal conductivity at ambient temperature (λ -value) shall be specified in the ETA.

2.2.7.5 Technical characterisation

The ETA shall contain the following information: product description, nature of the profiles, framework, studs (Classification in accordance with EN 10142, EN 10152, EN 10169 1, EN 10214 or EN 10215 (for steel), EN 573-3 (for aluminium) or EN 1912 (for timber), dimensions with tolerances and shape in accordance with this clause.

Note: The Assessment Body may require additional information and may adopt other verification methods.

⁴ Preference shall be given to test methods from the organization which is highest on the list.

3 ASSESSMENT AND VERIFICATION OF CONSTANCY OF PERFORMANCE

3.1 System(s) of assessment and verification of constancy of performance

3.1.1 For uses subject to reaction to fire regulations

The systems of assessment and verification of constancy of performance specified by the European Commission Decision 99/454/EC of 22 June 1999 (as amended) depending on the classes claimed by the manufacturer, in accordance with Table 9.

Table 9 - Systems of assessment and verification of constancy of performance

Product(s)	Intended use(s)	Level(s) or class(es)	System(s) of assessment and verification of constancy of performance ⁽¹⁾
Fire stopping and fire sealing products Fire protective products (including coatings)	For uses subject to reaction to fire regulations	A1*, A2*, B* and C*	1
		A1**, A2**, B**, C**, D, E	3
		(A1 to F)*** and NPD****	4
⁽¹⁾ Systems 1, 3 and 4: see Regulation (EU) N° 568/2014 * Products/materials for which a clearly identifiable stage in the production process results in an improvement of the reaction to fire classification (e.g. an addition of fire retardants or a limiting of organic material) ** Products/materials not covered by footnote (*) *** Products/materials that do not require to be tested for reaction to fire (e.g. Products/materials of classes A1 according to Commission Decision 96/603/EC, as amended). **** 'No Performance Declared' in accordance with Regulation (EU) N° 305/2011, Article 6(f)			

3.1.2 For fire compartmentation and/or fire protection or fire performances

The system of assessment and verification of constancy of performance specified by the European Commission Decision 99/454/EC of 22 June 1999 (as amended) is system 1, in accordance with Table 10.

Table 10 - Systems of assessment and verification of constancy of performance in accordance with EC Decision 99/454/EC

Product(s)	Intended use(s)	Level(s) or class(es) (resistance to fire)	Systems of assessment and verification of constancy of performance ⁽¹⁾
Fire Stopping and fire sealing products Fire protective products (including coatings)	For fire compartmentation and/or fire protection or fire performance	Any	1
⁽¹⁾ System 1: see Regulation (EU) N° 568/2014			

3.2 Tasks of the manufacturer

The cornerstones of the actions to be undertaken by the manufacturer of the product or kit in the procedure of assessment and verification of constancy of performance are laid down in Table 11.

Table 11 - Control plan for the manufacturer; cornerstones

No	Subject/type of control (product, raw/constituent material, component - indicating characteristic concerned)	Test or control method	Criteria, if any	Minimum frequency of control
Factory production control (FPC) [including testing of samples taken at the factory in accordance with a prescribed test plan]*				
1	Quality management (system)	See clause 3.4		
2	Incoming material	Declaration of conformity or tests according to quality manual	Manufacturer's declaration	Every delivery
3	Testing during production	According to quality manual	Manufacturer's declaration	According quality manual
Factory production control (FPC): testing on the final products Board, slabs and mats [including testing of samples taken at the factory in accordance with a prescribed test plan]*				
4	Determination of organic content (reaction to fire)	EN 13820	Manufacturer's declaration	1 per week
5	Determination of dimensional stability at high temperatures (fire resistance)	EN 1094-6 (sample size 100 mm x 100 mm)		1 per week
6	Indirect test method ⁵	-		As appropriate
7	Water permeability	Clause 2.2.2.8		1 per 3 years
8	Dimensional stability	Clause 2.2.2.10		1 per year
9	Thermal resistance	Clause 2.2.2.11		1 per 2 years
10	Water vapour transmission coefficient	Clause 2.2.2.12		1 per 2 years
Technical characterisation				
12	<ul style="list-style-type: none"> • Length, width 	Clause 2.2.2.13	Manufacturer's declaration	1 per day ⁶ , per dimension
13	<ul style="list-style-type: none"> • Thickness 			1 per day, per thickness
14	<ul style="list-style-type: none"> • Apparent density 		1 sample per n-boards	

⁵ Production shall be subjected to (at least) one additional FPC test that is related to fire resistance characteristics and that is especially relevant for the product under consideration. The manufacturer and the Assessment Body shall determine an appropriate frequency.

⁶ A day represents a 24 hour time period in which production is considered to be "normal".

No	Subject/type of control (product, raw/constituent material, component - indicating characteristic concerned)	Test or control method	Criteria, if any	Minimum frequency of control
15	<ul style="list-style-type: none"> Flexural strength 	Clause 2.2.2.9	Inspection S3 as in ISO 390, 4% AQL	1 sample per n-boards
Factory production control (FPC): testing on the final products				
Mechanical fasteners				
[including testing of samples taken at the factory in accordance with a prescribed test plan]*				
	Technical characterisation			
16	<ul style="list-style-type: none"> Hardness 	clause 2.2.3.4	Manufacturer's declaration	1 per day
17	<ul style="list-style-type: none"> Dimensions 			
18	<ul style="list-style-type: none"> Geometry 			
Factory production control (FPC): testing on the final products				
Adhesives				
[including testing of samples taken at the factory in accordance with a prescribed test plan]*				
19	Peel resistance	clause 2.2.4.3.1	Manufacturer's declaration	1 per week
20	Shear strength	clause 2.2.4.3.2		1 per day
	Technical characterisation			
21	<ul style="list-style-type: none"> Viscosity 	clause 2.2.4.4	Manufacturer's declaration	1 per day
22	<ul style="list-style-type: none"> Density 			
Factory production control (FPC): testing on the final products				
Jointing materials				
[including testing of samples taken at the factory in accordance with a prescribed test plan]*				
23	Tensile strength	clause 2.2.5.2.2.1	Manufacturer's declaration	1 per week
24	Adhesion/cohesion	clause 2.2.5.2.2.2		1 per week
	Technical characterisation			
25	Tensile strength / Viscosity	clause 2.2.5.3		1 per day
Factory production control (FPC): testing on the final products				
Insulation products				
[including testing of samples taken at the factory in accordance with a prescribed test plan]*				
	Thermal resistance	clause 2.2.6.4	Manufacturer's declaration	In accordance with relevant technical specification
	Moisture resistance	clause 2.2.6.2.1		
	Technical characterisation	clause 2.2.6.5		
Factory production control (FPC): testing on the final products				
Complete kits : The relevant individual part shall be evaluate as given above, In addition the following characteristics shall be verified and registered at a regular basis				
[including testing of samples taken at the factory in accordance with a prescribed test plan]*				
	Pull-through resistance	clause 2.2.1.5	Manufacturer's declaration	1 per week
	Shear load resistance	clause 2.2.1.6		1 per week
	Resistance to soft body impact	clause 2.2.1.7		1 per year
	Resistance to hard body impact	clause 2.2.1.8		1 per year

No	Subject/type of control (product, raw/constituent material, component - indicating characteristic concerned)	Test or control method	Criteria, if any	Minimum frequency of control
	Adhesion	clause 2.2.1.10		1 per week
	Technical characterisation			
	<ul style="list-style-type: none"> Nature and number of components 	clause 1.1.1	Manufacturer's declaration	1 per day
	<ul style="list-style-type: none"> Dimensions and geometry 			
* The test methods shall correspond to those included in the technical specification, but different equipment may be used, as long as correlation may be established. The manufacturer may also use external laboratories for these tests.				

3.3 Tasks of the notified body

The cornerstones of the actions to be undertaken by the notified body in the procedure of assessment and verification of constancy of performance for fire protective board, slab and mat products and kits are laid down in Table 12.

Table 12 - Control plan for the notified body; cornerstones

No	Subject/type of control (product, raw/constituent material, component - indicating characteristic concerned)	Test or control method	Criteria, if any	Minimum number of samples	Minimum frequency of control
Initial inspection of the manufacturing plant and of factory production control					
1	Assessment of the production control				
2	Assessment of technical data	Based on clause 2			
Continuous surveillance, assessment and evaluation of factory production control					
1	Results of FPC	See clause 3.2			2 per year

3.4 Special methods of control and testing used for the verification of constancy of performance

3.4.1 General

The manufacturer remains responsible for the product and any components supplied as part of a kit although the manufacturer may not manufacture all or any of them. The manufacturer's FPC system shall ensure consistency of manufacture and equivalent confidence in all components together with who is responsible (e.g. supplier or manufacturer) for conducting the evaluation.

If the product or kit components are supplied to the manufacturer, the supplier shall meet the requirements in Table 3.3 and the manufacturer shall ensure conformity with the supplier's declaration of conformity, by sample inspection of the incoming product or incoming components.

The supplier's declarations of conformity shall correspond with the principles of standards EN ISO 17050-1 and -2.

3.4.2 Product testing

On-going semi-manufactured and finished product testing shall be carried out in accordance with the manufacturer's documented FPC in order to verify continued conformity with the product specification. All materials, semi manufactured and finished products subject to testing and inspection shall be traceable through batch numbers or other manufacturer production references.

This production related testing shall be carried out by suitably trained / qualified personnel either directly employed by the manufacturer or by an external body acting on behalf of the manufacturer.

Records of all semi-manufacturing / finished product inspection and testing shall be traceable to raw material/ admix constituent conformity testing records.

3.4.3 Inspection and test status

The manufacturer's FPC shall detail the methods employed to demonstrate the inspection and test status of raw materials / admix constituents, semi manufactured product and finished product.

4 REFERENCE DOCUMENTS

As far as no edition date is given in the list of standards thereafter, the standard in its current version at the time of issuing the European Technical Assessment, is of relevance.

Where reference is made to a specific clause of a document, the document is dated. Assessment Bodies however may use more recent versions if the content of the clause is unchanged.

EN 13381-1	Test methods for determining the contribution to the fire resistance of structural members - Part 1: Horizontal protective membranes
EN 300	Oriented strand boards (OSB) - Definitions, classification and specifications
EN 318	Fibreboards - Determination of dimensional changes associated with changes in relative humidity
EN 319	Particleboards and fibreboards - Determination of tensile strength perpendicular to the plane of the board
EN 542	Adhesives - Determination of density
EN 573-3	Aluminium and aluminium alloys - Chemical composition and form of wrought products – Part 3: Chemical composition
EN 771-1	Specification for masonry units - Part 1: Clay masonry units
EN 771-2	Specification for masonry units - Part 2: Calcium silicate masonry units
EN 771-3	Specification for masonry units - Part 3: Aggregate concrete masonry units (dense and light-weight aggregates)
EN 771-4	Specification for masonry units - Part 4: Autoclaved aerated concrete masonry units
EN 771-5	Specification for masonry units - Part 5: Manufactured stone masonry units
EN 771-6	Specification for masonry units - Part 6: Natural stone masonry units
EN 789	Timber structures - Test methods - Determination of mechanical properties of wood-based panels
EN 822	Thermal insulating products for building applications - Determination of length and width
EN 823	Thermal insulating products for building applications - Determination of thickness
EN 824	Thermal insulating products for building applications - Determination of squareness
EN 826	Thermal insulating products for building applications - Determination of compressive behaviour
EN 923	Adhesives - Terms and definitions
EN 993-14	Methods of testing dense shaped refractory products - Part 14: Determination of thermal conductivity by the hot-wire (cross-array) method
EN 998-1	Specification for mortar for masonry - Part 1: Rendering and plastering mortar with inorganic binding agents
EN 998-2	Specification for mortar for masonry - Part 2: Masonry mortar
EN 1015-11	Methods of test for mortar for masonry - Determination of flexural and compressive strength of hardened mortar
EN 1015-12	Methods of test for mortar for masonry - Determination of adhesive strength of hardened rendering and plastering mortars on substrates
EN 1094-6	Insulating refractory products - Determination of permanent change in dimensions of shaped products on heating
EN 1239	Adhesives - Freeze/thaw stability
EN 1364-2	Fire resistance tests for non-loadbearing elements - Part 2: Ceilings
EN 1372	Adhesives - Test method for adhesives for floor and wall coverings - Peel test
EN 1373	Adhesives - Test method for adhesives for floor and wall coverings - Shear test
EN 1396	Aluminium and aluminium alloys - Coil coated sheet and strip for general applications – Specifications
EN 1507	Ventilation for buildings – Ductwork – Requirements for testing strength and leakage of rectangular sheet metal air ducts.
EN 1602	Thermal insulating products for building applications - Determination of the apparent density

EN 1603	Thermal insulating products for building applications - Determination of dimensional stability under constant normal laboratory conditions (23°C/50% relative humidity)
EN 1604	Thermal insulating products for building applications - Determination of dimensional stability under specified temperature and humidity conditions
EN 1607	Thermal insulating products for building applications - Determination of tensile strength perpendicular to faces
EN 1608	Thermal insulating products for building applications - Determination of tensile strength parallel to faces
EN 1609	Thermal insulating products for building applications - Determination of short term water absorption by partial immersion
EN 1766	Products and systems for the protection and repair of concrete structures - Test methods - Reference concretes for testing
EN 1912	Structural timber - Strength classes - Assignment of visual grades and species
EN 1990:2002	Eurocode - Basis of structural design
EN 1993 series	Eurocode 3 - Design of steel structures
EN 1995 series	Eurocode 5 - Design of timber structures
EN 1999 series	Eurocode 9 - Design of aluminium structures
EN 10002-1	Tensile testing of metallic materials - Method of test at ambient temperature
EN 10020	Definition and classification of grades of steel
EN 10088	Stainless steels - List of stainless steels
EN 10142	Continuously hot-dip zinc coated low carbon steels strip and sheet for cold forming - Technical delivery conditions
EN 10147	Continuously hot-dip zinc coated structural steels strip and sheet - Technical delivery conditions
EN 10152	Electrolytically zinc coated cold rolled steel flat products - Technical delivery conditions
EN 10169-1	Continuously organic coated (coil coated) steel flat products – Part 1: General information (definitions, materials, tolerances, test methods)
EN 10214	Continuously hot-dip zinc-aluminium (ZA) coated steel strip and sheet - Technical delivery conditions
EN 10215	Continuously hot-dip aluminium-zinc (AZ) coated steel strip and sheet - Technical delivery conditions
EN 10327	Continuously hot-dip coated strip and sheet of low carbon steels for cold forming - Technical delivery conditions
EN 12086	Thermal insulating products for building applications - Determination of water vapour transmission coefficient
EN 12089	Thermal insulating products for building applications - Determination of bending behaviour
EN 12092	Adhesives - Determination of viscosity
EN 12101-1	Smoke and heat control systems - Part 1: Specification for smoke barriers
EN 12101-2	Smoke and heat control systems - Part 2: Specification for natural smoke and heat exhaust ventilators
EN 12101-3	Smoke and heat control systems – Part 3: Specification for powered smoke and heat exhaust ventilators
EN 12101-4	Smoke and heat control systems - Part 4: Installed SHEVS systems for smoke and heat ventilation
CEN/TR 12101-5	Smoke and heat control systems - Part 5: Guidelines on functional recommendations and calculation methods for smoke and heat exhaust ventilation systems
EN 12101-6	Smoke and heat control systems - Part 6: Specifications for pressure differential systems – Kits
EN 12101-10	Smoke and heat control systems - Part 10: Power supplies
EN 12365-1	Building hardware - Gasket and weatherstripping for doors, windows, shutters and curtain walling - Part 1: Performance requirements and classification.
EN 12412-2	Thermal performance of windows, doors and shutters - Determination of thermal transmittance by hot box method – Part 2: Frames
EN 12467:2012	Fibre-cement flat sheets - Product specifications and test methods
EN 12664	Thermal performance of building materials and products - Determination of thermal resistance by means of guarded hot plate and heat flow meter methods -

EN 12667	Dry and moist products of medium and low thermal resistance Thermal performance of building materials and products - Determination of thermal resistance by means of guarded hot plate and heat flow meter methods - Products of high and medium thermal resistance
EN 12939	Building materials - Determination of thermal resistance by means of guarded hot plate and heat flow meter methods - Thick products of high and medium thermal resistance
EN 13162	Thermal insulation products for buildings - Factory made products of Mineral Wool (MW) – Specification
EN 13238	Reaction to fire tests for building products - Conditioning procedures and general rules for selection of substrates
EN 13403	Ventilation for buildings – Non-metallic ducts – Ductwork made from insulation ductboards
EN 13467	Thermal insulating products for building equipment and industrial installations - Determination of dimensions, squareness and linearity of preformed pipe insulation
EN 13501-1	Fire classification of construction products and building elements - Part 1: Classification using test data from reaction to fire tests
EN 13501-2	Fire classification of construction products and building elements - Part 2: Classification using test data from fire resistance tests
EN 13501-3	Fire classification of construction products and building elements - Part 3: Classification using data from fire resistance tests on components of normal building service installations
EN 13501-4	Fire classification of construction products and building elements - Part 4: Classification using test data from fire resistance tests on smoke control systems
EN 13820	Thermal insulating materials for building applications - Determination of organic content
EN 13823	Reaction to fire tests for building products - Building products excluding floorings exposed to the thermal attack by a single burning item
EN 13964:2004	Suspended ceilings – Requirements and test methods
EN 24624	Paints and varnishes - Pull-off test
EN ISO 527-1	Plastics - Determination of tensile properties - General principles
EN ISO 527-2	Plastics - Determination of tensile properties - Test conditions for moulding and extrusion plastics
EN ISO 3506-1	Mechanical properties of corrosion-resistant stainless steel fasteners - Part 1: Bolts, screws and studs
EN ISO 3506-2	Mechanical properties of corrosion-resistant stainless steel fasteners - Part 2: Nuts
EN ISO 3506-3	Mechanical properties of corrosion-resistant stainless-steel fasteners - Part 3: Set screws and similar fasteners not under tensile stress
EN ISO 8339	Building construction - Sealants - Determination of tensile properties (Extension to break) (ISO 8339:2005)
EN ISO 9047	Building construction - Jointing products - Determination of adhesion/cohesion properties of sealants at variable temperatures (ISO 9047:2001)(+AC:2009)
EN ISO 10077-2	Thermal performance of windows, doors and shutters - Calculation of thermal transmittance - Part 2: Numerical method for frames
EN ISO 10456	Building materials and products - Hygrothermal properties -Tabulated design values and procedures for determining declared and design thermal values
EN ISO 10590	Building construction - Sealants - Determination of tensile properties of sealants at maintained extension after immersion in water (ISO 10590:2005)
EN ISO 11431	Building construction - Jointing products - Determination of adhesion/cohesion properties of sealants after exposure to heat, water and artificial light through glass (ISO 11431:2002)
EN ISO 11600	Building construction - Jointing products - Classification and requirements for sealants (ISO 11600:2002)
EN ISO 12572	Hygrothermal performance of building materials and products - Determination of water vapour transmission properties (ISO/DIS 12572:1997)
EN ISO 12944-3	Paints and varnishes - Corrosion protection of steel structures by protective paint systems - Design considerations

EN ISO 13787	Thermal insulation products for building equipment and industrial installations - Determination of declared thermal conductivity
EN ISO 13788	Hygrothermal performance of building components and building elements - Internal surface temperature to avoid critical surface humidity and interstitial condensation - Calculation methods
ISO 390	Products in fibre-reinforced cement - Sampling and inspection
ISO 5922	Malleable cast iron
prEN 1015-20	Methods of test for mortar for masonry - Determination of durability of hardened masonry mortars (with cement comprising less than or equal to 50% of the total binder mass)
ISO/DIS 8413	Performance Standards in Building - Partitions made from Components - Tests for Ability to withstand Suspended Static Loads
EOTA TR001:2003	Determination of impact resistance of panels and panel assemblies
EOTA TR024	Characterisation, aspects of durability and factory production control for reactive materials, components and products
CEN/TS 16637-2	Construction products – Assessment of release of dangerous substances – Part 2: Horizontal dynamic surface leaching test
EN ISO 6341	Water quality - Determination of the inhibition of the mobility of <i>Daphnia magna</i> Straus (Cladocera, Crustacea) - Acute toxicity test (ISO 6341:2012)
EN ISO 11348-1	Water quality - Determination of the inhibitory effect of water samples on the light emission of <i>Vibrio fischeri</i> (Luminescent bacteria test) - Part 1: Method using freshly prepared bacteria (ISO 11348-1:2007)
EN ISO 11348-2	Water quality - Determination of the inhibitory effect of water samples on the light emission of <i>Vibrio fischeri</i> (Luminescent bacteria test) - Part 2: Method using liquid-dried bacteria (ISO 11348-2:2007)
EN ISO 11348-3	Water quality - Determination of the inhibitory effect of water samples on the light emission of <i>Vibrio fischeri</i> (Luminescent bacteria test) - Part 3: Method using freeze-dried bacteria (ISO 11348-3:2007)
ISO 15799	Soil quality - Guidance on the ecotoxicological characterization of soils and soil materials

ANNEX A - List of annexes

ANNEX A - List of annexes

ANNEX B - EN 13823: Reaction to fire tests for building products - Building products excluding floorings exposed to the thermal attack by a single burning item - Mounting and fixing provisions

ANNEX C - Assessment for composite boards

ANNEX D - Freeze/thaw conditioning for use category Y

ANNEX B - EN 13823: Reaction to fire tests for building products - Building products excluding floorings exposed to the thermal attack by a single burning item - Mounting and fixing provisions

B.1 Terminology

Extended application:

The outcome of a process (involving the application of defined rules that may incorporate calculation procedures) that predicts, for a variation of a product property and/or its intended end use application(s), a test result on the basis of one or more test results to the same test standard

Note: These mounting and fixing provisions may only be used to determine the reaction to fire class of boards, slabs and mats. The procedure for testing tiles, if they are not Class 1, is to be agreed between the applicant and the Assessment Body.

B.2 Mounting & Fixing in accordance with EN 13823

B.2.1 Dimensions of the test rig

The test rig consists of a corner, with a long (1,0 m) and a short wing (0,5 m). The long wing consists of 2 boards, with one vertical and one horizontal board-to-board joint in between. All boards shall be tested vertically. The dimensions of the specimens shall be:

	Assembly dimensions (mm – nominally)	
	Length	Height
Short wing	500	1500
Long wing	200 + t	1500
	800	1500
Where t = thickness of the board Note: Given that the thickness is relatively small, test performed with the length of the long wing including the thickness will be accepted as well.		

B.2.2 Test specimen

Fire protective boards shall be mounted and fixed according to EN 13823 and as specified below.

The boards used in the test assembly shall always include all facings and/or coatings that are applied to the product, as it is placed onto the market. Each facing and/or coating type requires new tests.

Test results from boards with maximum facing or coating thickness are valid for thinner coatings as well (for intumescent coatings the same applies).

Influences of different colours of facings or coatings may be determined by performing indicative SBI tests on a light and on a dark colour. If the colour does not lead to a change in class or sub-class (smoke and droplets) then the full scale SBI is only conducted on one colour.

The assembly, including the joint detail and corner detail, shall be in accordance with end use conditions, as specified by the ETA-applicant.

Due to the specific requirements of the test standard, it may not be possible to mount the boards as usually specified by the ETA-applicant. In that case, the mounting arrangement shall be as similar as possible and agreed between ETA-applicant and Assessment Body.

The type and dimensions of materials and products used, the dimensions and mechanical fasteners' location, etc shall be recorded in the test report.

B.2.3 Mounting and fixing of the test assembly

B.2.3.1 Assemblies with framework/studs (see figures B.1 to B.5)

The boards shall be fixed on a (structural) framework, using the fixing system and, if relevant, the jointing material, profile, etc., as specified by the manufacturer, representing the tight joint, achieved in end use (see figures B.1 to B.5).

In accordance with EN 13823, the minimum distance between the backing boards and the fire protective board samples shall be 40 mm, using spacer bars at top and bottom. The frame between backing board and specimen shall be open at the sides to allow ventilation into the gap.

Note: The assembly may be prepared and fixed together away from the test chamber. The complete assembly may then be transported to the chamber.

The boards are mounted on a framework made out of timber, (40 ± 1) mm by (40 ± 1) mm for vertical members, (20 ± 1) mm by (40 ± 1) mm for horizontal members. Test results for timber framework also apply for metal framework. In case the ETA-applicant claims better performance with metal studs or in case the ETA-applicant does not use timber framework, the test may also be performed with the most onerous type (related to dimensions and thickness of the profiles) of metal framework. If larger filling material thicknesses are used (see below), then the stud dimensions need to be increased accordingly.

If the kit contains filling material for introduction behind the fire protective board, such as mineral wool, the gap between backing board and specimen shall be filled completely, to establish contact between the insulation and the fire protective board.

The type of filling material shall meet the manufacturer's specifications, but a (50 ± 5) mm thick mineral wool slab, density $(35 \pm 10 \text{ kg/m}^3)$, Euroclass A1/A2-s1,d0 (organic binder $< 5 \%$; melting point $> 1000 \text{ }^\circ\text{C}$), may be used as a typically used filling material. The mineral wool is fixed on the substrate, in accordance with manufacturer's specifications.

To assess the filling material's influence, tests may be necessary on the smallest and largest thicknesses and the smallest and largest densities (these may vary between 20 kg/m^3 and 190 kg/m^3).

If any other filling material is used, this has to be considered and tested.

The cut edge of the short wing board shall be placed against the long wing assembly to form an internal corner. On the long wing, a vertical joint is situated 200 mm from the internal corner and a horizontal joint 500 mm from the bottom.

These joints shall be constructed as in practice (usually, these are butt joints), but these are normally not larger than 3 mm (dimension x in the figures B.1 to B.5). The test result is valid only for joints with the width used in the test or smaller joints. In accordance with the manufacturer's end use specifications, the joints may be filled and/or strips may be foreseen on the framework.

The two wings shall then be secured at 90° to each other, using the corner finishing products (jointing material, profile, etc.) in accordance with end use conditions, as specified by the manufacturer.

If the ETA-applicant does not normally use a particular mechanical fastener, rivets, clips or screw fixings meeting the ETA-applicant's minimum performance criteria shall be used. The type of mechanical fastener used during the tests shall be agreed between ETA-applicant and Assessment Body.

In any other case, the manufacturer's mechanical fasteners shall be used.

The fastening pattern and number of mechanical fasteners shall correspond to the kit or component manufacturer's specifications. They shall be reported in the test report.

B.2.3.2 Assemblies without framework (see figures B.3 to B.5)

These tests shall be used for boards, slabs and mats that are mechanically fixed or adhered onto the substrate, without the use of studs or framework.

In this case, the boards, slabs or mats shall be adhered with the adhesive in accordance with manufacturer's specifications. The quantity and pattern of adhesive shall correspond to the kit or component manufacturer's specifications. This information shall be reported in the test report. In figure B.5, the boards and studs are not included. One or more of the substrates defined in EN 13238 shall be used.

Note: If the ETA-applicant chooses to perform the test using alternative substrates, he will not be able to benefit from the direct application rules provided in EN 13238.

If the manufacturer does not normally use a particular mechanical fasteners, rivets, clips or screw fixings meeting the manufacturer's minimum performance criteria shall be used. In that case, the type of mechanical fasteners used during the tests shall be agreed between manufacturer and Assessment Body.

In any other case, the manufacturer's mechanical fasteners shall be used.

The fastening pattern and number of mechanical fasteners to be used is given on the figures B.3 and B.4.

B.3 Figures

Tolerances on dimensions as presented in figures B.1 to B.5 are ± 1 mm.

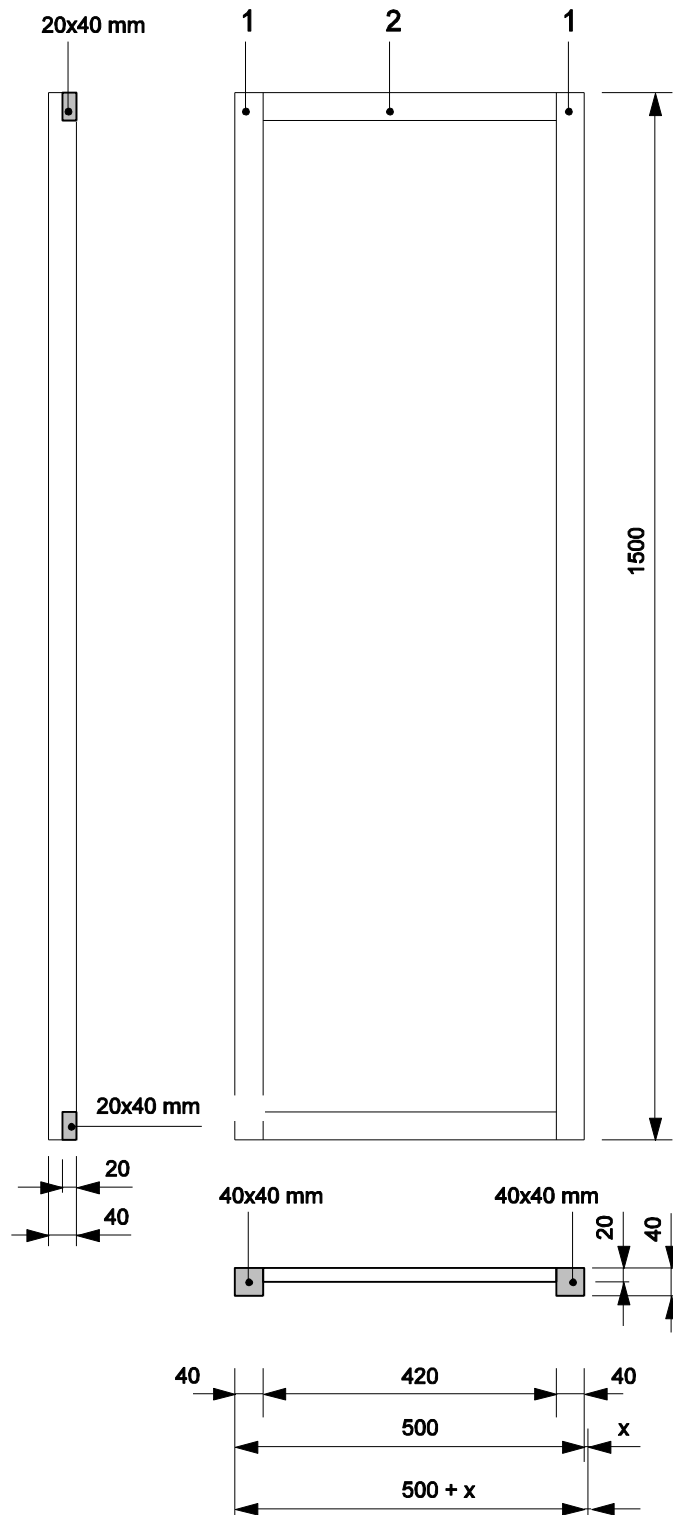

- Key**
- 1 Vertical frame members
 - 2 Horizontal frame members
 - x Joint width

Dimensions in mm

Figure B.1: Framework for short wing in EN 13823

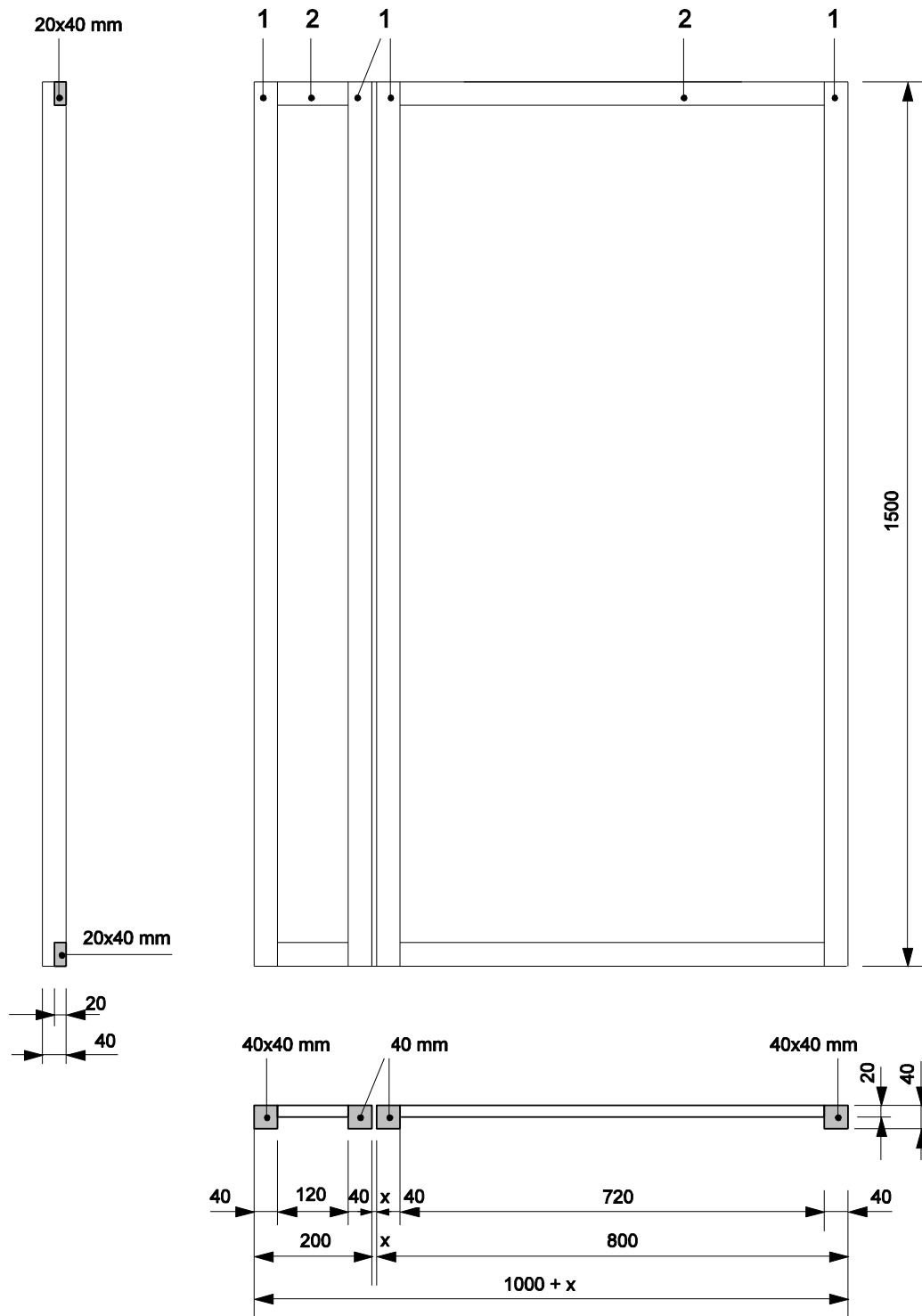

Key

- 1 Vertical frame members
- 2 Horizontal frame members
- x Joint width

Dimensions in mm

Figure B.2: Framework for long wing in EN 13823

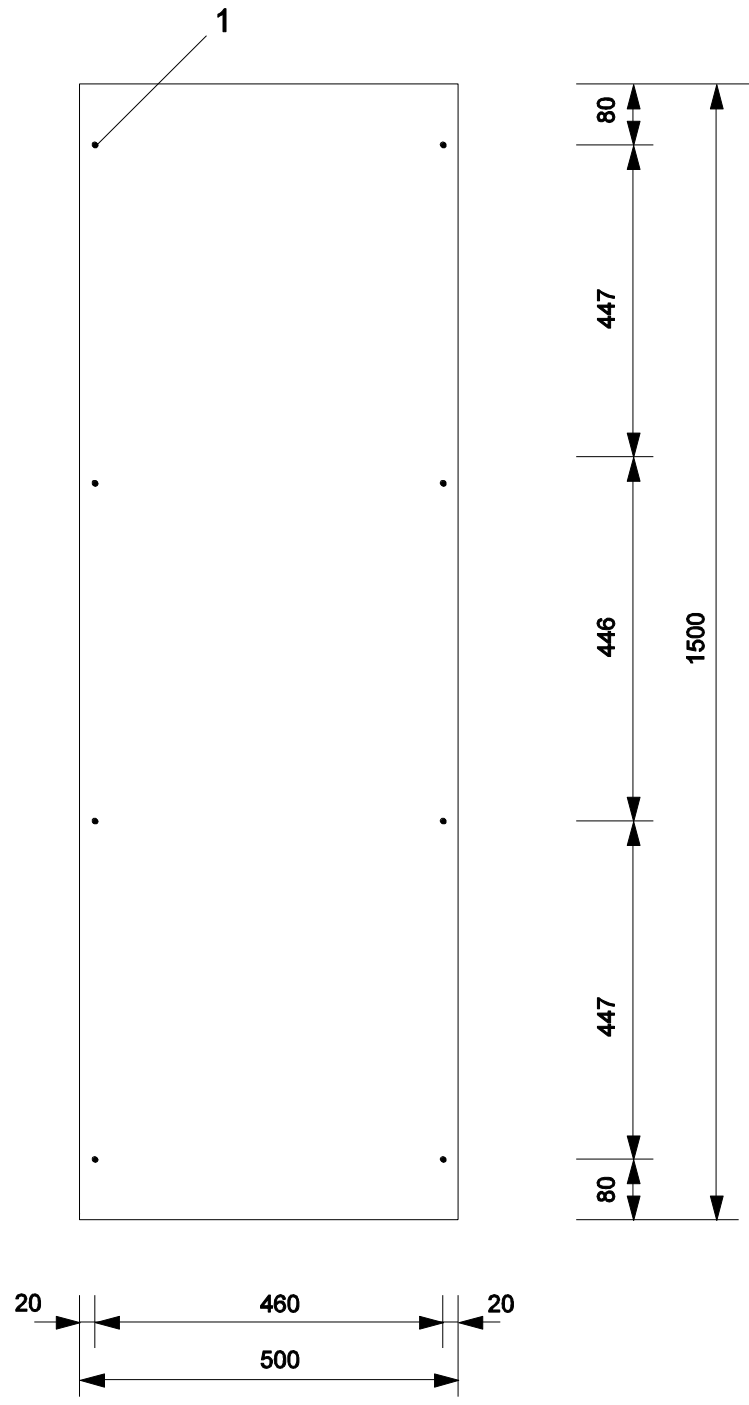

Key
1 Mechanical fastener

Dimensions in mm

Figure B.3: Fixing of boards, slabs and mats for short wing in EN 13823

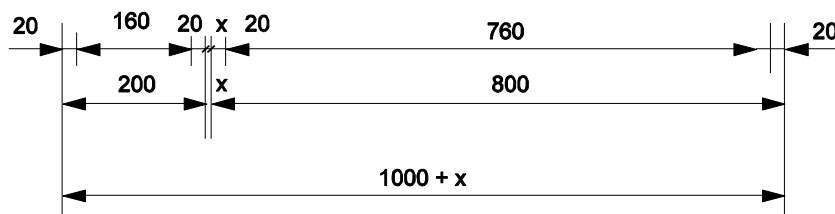
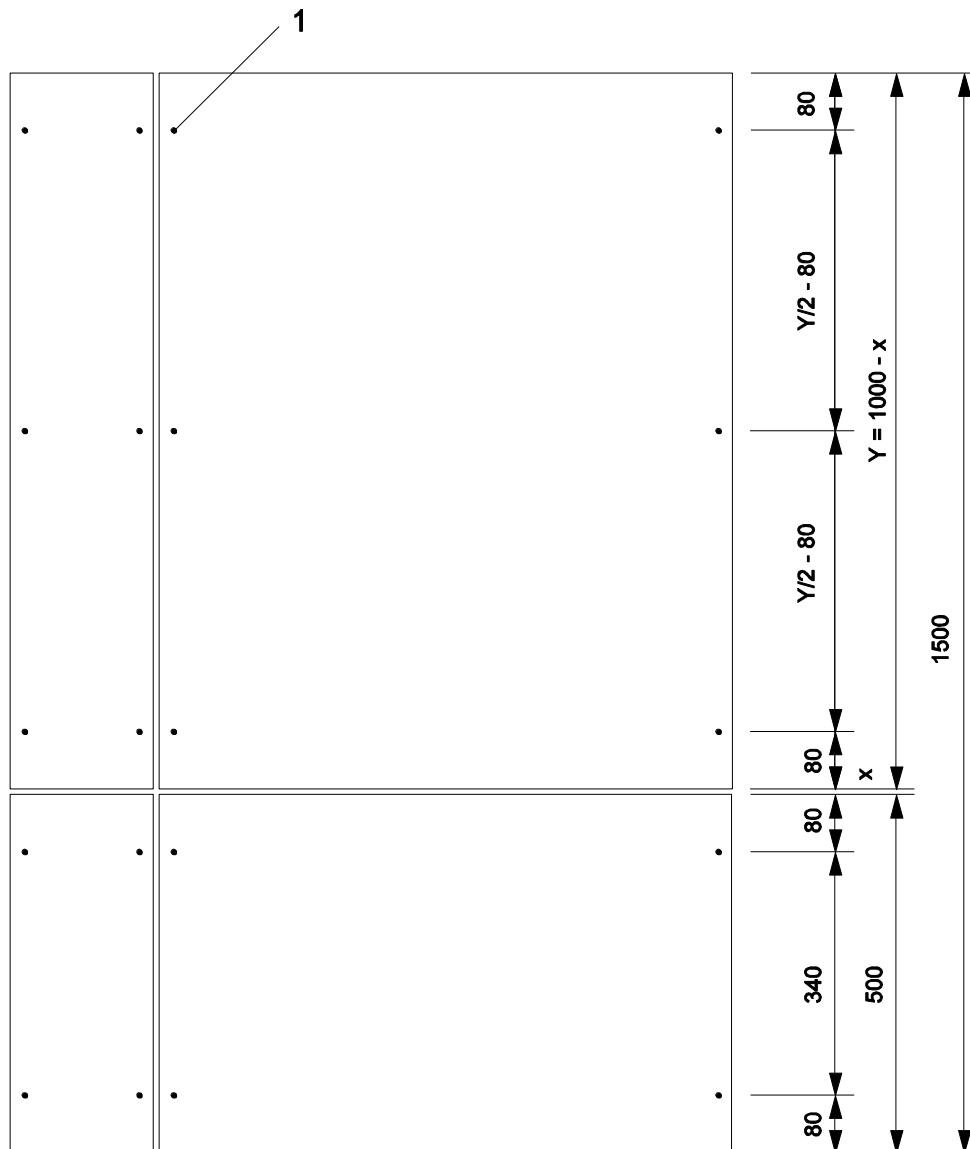

Key

- 1 Mechanical fastener
- x Joint width

Dimension in mm

Figure B.4: Fixing of boards, slabs and mats for long wing in EN 13823

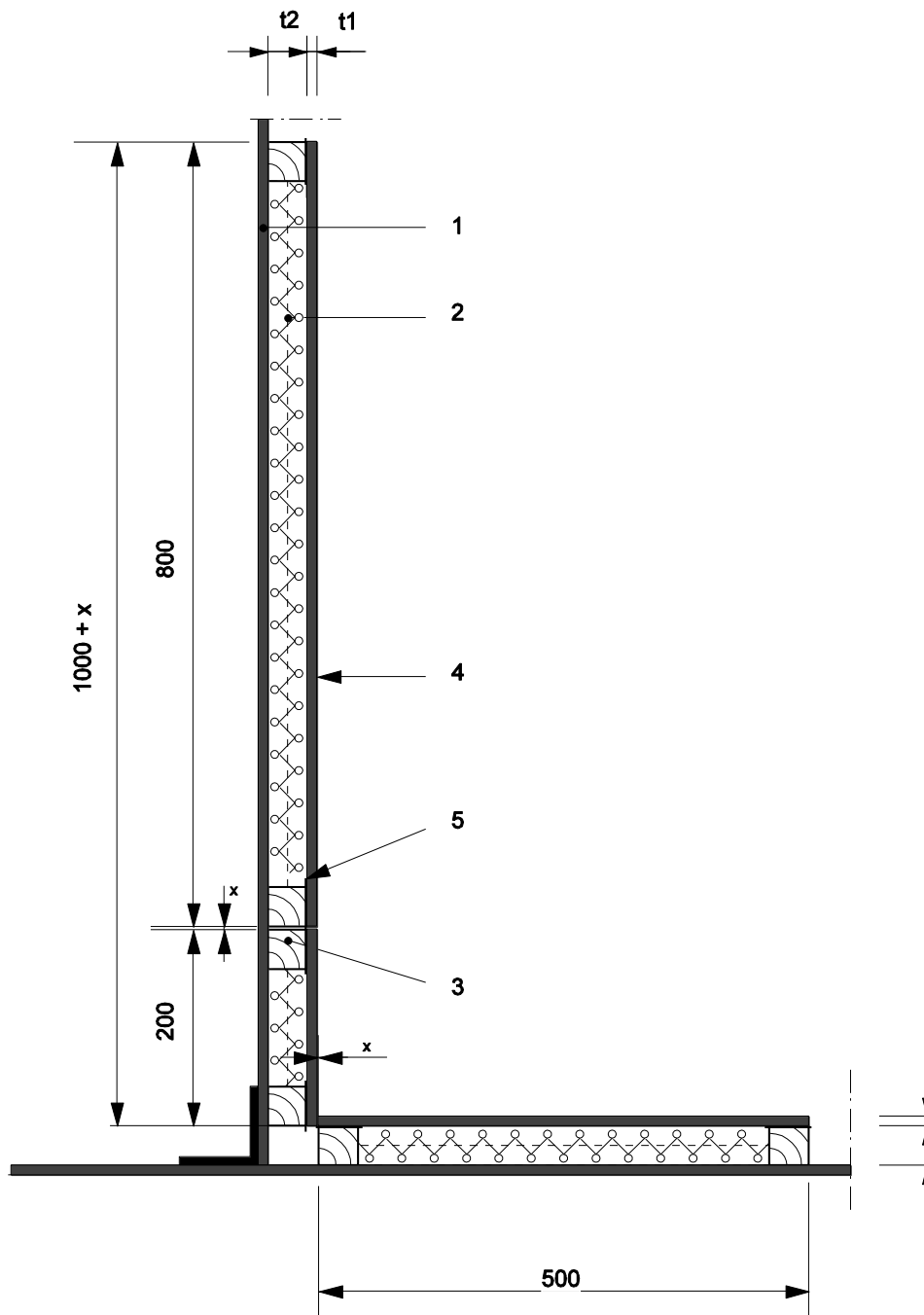

Key

- 1 Backing board
- 2 Insulation
- 3 Vertical member
- 4 Board
- 5 Joint material
- x Joint width

Dimensions in mm

Figure B.5: Schematic Mounting and fixing arrangement in EN 13823

ANNEX C - ASSESSMENT FOR COMPOSITE BOARDS

C.1 General

Boards consisting of two or more layers of materials require additional assessment, which may be regarded as serviceability assessment, and which depends on the nature of the materials involved and the bonding method. The assessment is presented below. However, depending on the nature of the materials involved and the bonding method, further assessment might be deemed necessary.

C.2 Reactive layers

If the board contains reactive layers or finishings, these reactive materials shall be assessed in accordance with EOTA Technical report 024.

C.3 Tensile strength perpendicular to the board faces

The tensile strength perpendicular to the board faces shall be determined and specified in the ETA in accordance with EN 1607.

C.4 Compatibility

The compatibility of the materials involved, taking into account the intended use, shall be assessed. The Assessment Body shall indicate which assessment took place and shall state limitations of intended use in the ETA, if relevant.

C.5 Assessment

Every statement in the ETA represents the assessment of the component's performance made under the responsibility of the Assessment Body, taking into account the intended use.

ANNEX D - FREEZE/THAW CONDITIONING FOR USE CATEGORY Y

D.1. Principle

This annex describes the conditions and procedures which need to be observed when conditioning fire protective boards of type Y in condensation water alternating atmospheres.

The tests are designed to establish any defects in the protection of the test specimen against the combined influence of condensation and freeze/thaw.

D.2. Cycles

The test specimen shall be subjected to 25 cycles. Each cycle has a duration of 24 hours and is as follows:

Time (min, ± 5 min.)	Temperature (°C, ± 2°C)	Relative humidity (%, ± 5%)
240	23	95
120	Decrease to -10	Uncontrolled, but climate chamber remains shut
960	-10	
120	Increase to 23	

D.3. Apparatus

The material of the inner walls of the vapour-tight climatic chamber shall be corrosion-resistant and shall not affect the test panels. The climatic chamber is usually equipped with a floor trough which acts as the receptacle for the water.

The test chamber shall be tempered by heating the water in the floor trough. If the quantity of heat introduced via the water is insufficient to raise the air temperature in the test room to the required level, then additional heating may be employed.

Note 1 The heating-up time will depend on the nature and quantity of the test panels, and also on the ratio of the water surface of the floor trough to the wall surface of the test chamber, and on the water temperature.

The climatic chamber shall be provided with an appropriate door or other aperture capable of being closed, which allows the test chamber to be charged with test panels and to be ventilated.

Note 2 An example of a condensation water climatic testing device is given in Figure D.1.

Climatic testing devices not equipped with water-filled floor troughs shall be fitted out in such a way that an adequate formation of condensation water on the test panels is achieved.

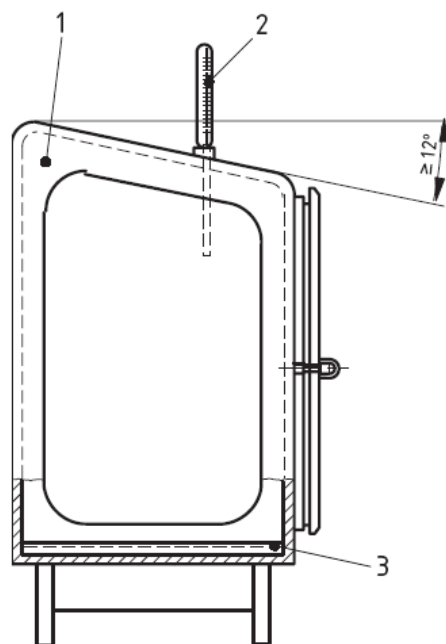
**Key⁷**

- 1) pressure relief valve
- 2) temperature measuring device
- 3) floor trough filled with water

Figure D.1 - Example of a condensation water climatic testing device

D.4. Procedure

D.4.1 Filling the floor trough

The floor trough shall be filled with water in such a way that a depth of water of at least 10 mm is present at all times during operation.

Note It is recommended that distilled or de-ionized water is used to avoid calcification of the apparatus.

D.4.2 Test panels

Only test specimens that do not mutually influence one another shall be tested together at any one time.

D.4.3 Arrangement of the test panels

The test panels shall be vertically arranged in the chamber in such a way that they are not in close contact with each other and that they are able to adequately radiate heat.

The following minimum spacings shall be observed:

distance from the walls	not less than 100 mm
distance of the bottom edge of the test panel from the surface of the water	not less than 200 mm
spacing between adjoining test panels	not less than 20 mm

Precautions shall be taken to ensure that no condensation water is allowed to drip onto the test panels from the walls or ceiling of the test chamber, nor from other test panels.

⁷ The apparatus is given as an example. Any equipment achieving the same conditions is acceptable.

D.4.4 Test sequence

D.4.4.1 Start-up

Place the test panels in position, close the climatic chamber and switch on the heating for the floor trough water or for the climatic testing device. Heat the chamber to $(23 \pm 2) ^\circ\text{C}$, attaining this temperature within 30 min. Condensation water shall be formed on the test panels.

D.4.4.2 Cycles

4 hours after commencement of the start-up phase (see above), switch off the heating and terminate the condensation process (first test period). Cool the climatic chamber to $(-10 \pm 2) ^\circ\text{C}$, without opening the cabinet. The cooling down period shall be finalised within 2 hours.

After a further 16 hours, switch on the heating again and heat, within 2 hours, until $(23 \pm 2) ^\circ\text{C}$ and $(95 \pm 5) \%$. Commence a new cycle. Check and top up if necessary the water level in the floor trough.

Test specimen shall not be removed from the climatic chamber before end of all the cycles.