

# Resistance to impact for saddles

-interpretation document-

**Practical experience has shown that when testing saddles the striker of type D25 falls into the threaded connection. This gives a completely different impact load than what the test is intended for.**

The resistance to impact for saddles shall be performed according to below description. When a BRL is updated, this description will be included.

## Mechanical characteristics

### Resistance to impact

The determination of the resistance to impact shall be performed according to ISO 3127.

Because ISO 3127 is intended to test pipes, the following adjustments are necessary to make the test suitable for saddles:

- The sides of the saddle should be supported as shown in figure 1 by means of adjustable side supports;
- Conditioning: at least 30 minutes at a temperature of  $(0 \pm 2) ^\circ\text{C}$ , e.g. using an ice / water mixture;
- The test temperature is  $(0 \pm 2) ^\circ\text{C}$ ;
- The mass of the striker and the drop height dependent on the nominal diameter shall be conform Table 1;
- The drop weight must strike the saddle centric;
- The nose of the striker shall be a flat circular disc with a diameter of 85 mm and a thickness of approximately 10 mm;
- Required number of test pieces: Initially, there should be 10 full saddles to be tested (upper and lower saddle). If an upper saddle or lower saddle fails, the test shall be extended by a further 20 complete saddles (upper and lower saddle);
- Requirement: Not more than 3 out of 30 saddles shall fail to satisfy the requirement (TIR <10%).

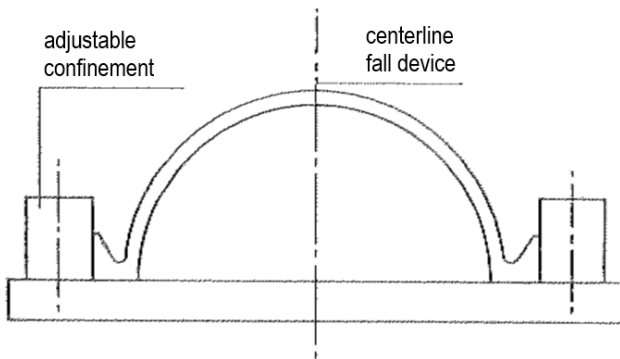

Figure 1 - Support of the saddle for the impact test

Table 1: Mass and drop height of the striker

Nominal outside diameter of pipe the saddle is intended to	Mass of striker	Drop height
$\leq 110$ mm	2000 $^{+5}_{-0}$ g	500 $^{+5}_{-0}$ mm
$\geq 125$ mm	2000 $^{+5}_{-0}$ g	1000 $^{+5}_{-0}$ mm